

Solutions
architecturales
pour le verre
Architectural
glass
solutions

N°6

The global leader in
door opening solutions*

*Leader mondial des solutions
de sécurisation des accès

Contrôle d'accès <i>Access control</i>			
Serrure motorisée shine <i>Motorised lock Shine</i>	P.1	Lagune Serrure de milieu <i>Lock</i>	P.64
Bandeaux électriques sans encoche série 9700 <i>Notchless electric midrails 9700 series</i>	P.2	Serrure de milieu à déport <i>Offset mechanism Lock</i>	P.68
Serrure électrique V-Lock <i>Electric lock V-Lock</i>	P.4	Serrure de milieu à déport et pêne désaxé <i>Offset mechanism and spring bolt lock</i>	P.74
Gâche électrique <i>Electric keep</i>	P.7	Kits serrure Lagune <i>Kits lock Lagune</i>	P.75
Ventouse magnétique <i>Magnetic contact</i>	P.8	Artis	P.76
CODE HANDLE Vertis	P.9	Serrure de milieu <i>Lock</i>	P.78
CODE HANDLE Lumira	P.12	Serrure de milieu à déport <i>Offset mechanism Lock</i>	P.79
	P.14	Serrure de milieu à déport et pêne désaxé <i>Offset mechanism and spring bolt lock</i>	P.80
	P.15	Bastille Serrure de milieu à déport et pêne désaxé <i>Offset mechanism and spring bolt lock</i>	P.84
Portes automatiques <i>Automatic doors</i>	P.16-38	Lumira	P.89
Automatismes pour porte coulissante intérieure : SLIDEMATIC <i>Sliding door operators for interior applications : SLIDEMATIC</i>	P.19-167	Serrure de milieu à déport et pêne désaxé <i>Offset mechanism and spring bolt lock</i>	P.90
Automatismes pour porte battante <i>Swing door operators</i>	P.21	Kits serrure Lumira <i>Kits lock Lumira</i>	P.92
	P.22-24	Vertis Serrure de milieu à déport et pêne désaxé <i>Offset mechanism and spring bolt lock</i>	P.96
Systèmes pour portes coulissantes en verre <i>Systems for sliding glass doors</i>	P.23	Vertis SQ	P.99
Slice 60	P.26-28	Serrure de milieu (1300) <i>Lock (1300)</i>	P.100
Système coulissant, poids maxi par porte : 60 kg <i>Sliding door system, maximum door weight : 60 kg</i>	P.30-32	Classic	P.104
Slice Synchro	P.34	Serrure de milieu (1300) <i>Lock (1300)</i>	P.106
Système synchronisé pour porte coulissante, poids maxi par porte : 60 kg <i>Simultaneous opening system for sliding doors, maximum door weight : 60 kg</i>	p.36	Open Glass	P.110
Slice 100	P.40	Kit rénovation pour porte intérieure <i>Renovation kit for interior door</i>	P.114
Système coulissant, poids maxi par porte : 100 kg <i>Sliding door system, maximum door weight : 100 kg</i>	P.42	Doorframe	P.115
Slice Automove	P.54	Profil d'encadrement porte en verre <i>Door frame profile for glass doors</i>	P.116
Système coulissant, poids maxi par porte : 80 kg <i>Sliding door system, maximum door weight : 80 kg</i>	P.58	Joint PVC pour panneaux fixes en verre <i>Tape for jointing fixed panels</i>	P.118
Magic Slide	P.61	Lagune & Lumira	P.120
Système coulissant, poids maxi par porte : 80 kg <i>Sliding door system, maximum door weight : 80 kg</i>	P.62	Paumelles <i>Hinges</i>	P.121
Cilindric Automove	P.16-38	Lagune	
Système coulissant, poids maxi par porte : 80 kg <i>Sliding door system, maximum door weight : 80 kg</i>	P.40	Fiches séries 3204 – 3205 – 3206 <i>Butts series 3204 – 3205 – 3206</i>	
Cilindric Automove	P.42	Bastille	
Système coulissant, poids maxi par porte : 80 kg <i>Sliding door system, maximum door weight : 80 kg</i>	P.54	Paumelles <i>Hinges</i>	
Slidematic	P.58	Fiches séries 4208 – K3172 <i>Butts series 4208 – K3172</i>	
Couillants automatiques d'intérieur <i>Automatic interior sliding systems</i>	P.61	Vertis	
Tableau de synthèse des systèmes pour portes coulissantes <i>Technical features table of systems for sliding glass doors</i>	P.62	Paumelles & fiches <i>Hinges & butts</i>	
Easyfold	P.66	Freeline	
Systèmes pour portes repliables <i>Folding door systems</i>	P.68	Charnières hydrauliques <i>Hydraulic hinges</i>	
Flexystack 250	P.74	Swingo	
Systèmes pour parois mobiles <i>Stacking door systems</i>	P.75	Charnière à rappel automatique <i>Automatic return single hinge</i>	
Accessoires pour portes coulissantes <i>Sliding doors accessories</i>	P.76	Lumira	
	P.77	Pentures séries V590 <i>Hinges series V590</i>	
	P.78	Loqueteaux <i>Clip-on locks</i>	
	P.79		
	P.80		
	P.84		
	P.89		
	P.90		
	P.92		
	P.96		
	P.99		
	P.100		
	P.104		
	P.106		
	P.110		
	P.114		
	P.115		
	P.116		
	P.118		
	P.120		
	P.121		

Serrures et paumelles
*Locksets and hinges*Accessoires pour porte en verre
Glass door accessories

Pentures, serrures et pièces de fixation			
<i>Locks and patch fittings</i>			
Pentures 101	P.123	Marine SQ	P.226
Serrures basses, boîtier gâche et gâche séries 1358		Carréa	P.228
<i>Bottom lock, matching patch keep and keep with guard series 1358</i>	P.124	Maréva	P.230
Verrou cavalier à demi-cylindre 1435	P.126	Cales pour charnières	P.234
<i>Clip on lock with half euro profile cylinder 1435</i>	P.128	Coralia	P.236
Pentures Cilindric®/Pentures Cilindric®	P.130	Coralia SQ	P.238
<i>Patch fitting Cilindric®/Patch fitting Cilindric®</i>			
Poignées Cilindric®/Poignées Cilindric®	P.136-189	Tableau de synthèse pour charnières de douches	P.240
<i>Handles Cilindric®/Handles Cilindric®</i>		<i>Technical features table for shower hinges</i>	
Pentures PF	P.138	Pièces de fixation pour volumes fixes de douches	P.242
<i>PF Patch fitting</i>		<i>Partition clips for fixed shower screens</i>	
Serrures anti-paniques	P.145	Profil de compensation	P.248
<i>Anti-panic locks</i>		<i>Correcting profiles</i>	
Plinthes FRP	P.149	Profil raidisseur sol/plafond pour paroi fixe	P.250
<i>Door rails FRP</i>		<i>Floor to ceiling support for fixed shower screen</i>	
Profil brosse	P.156	Profil alu. U et L	P.252
<i>U profile with brush</i>		<i>U & L aluminium profile</i>	
Plinthe automatique pour porte en verre	P.62-159	Barres raidisseurs pour volumes fixes	P.253
<i>Drop-down seal for glass door</i>		<i>Reinforcement bars for fixed panels</i>	
Profil alu. U et L	P.160	Accessoires pour barre raidisseur Ø 22 mm	P.259
<i>U & L aluminium profile</i>		<i>Accessories for reinforcement bar Ø 22 mm</i>	
Profil de serrage	P.162	Porte serviettes et porte tablettes	P.261
<i>Glass clamp profile</i>		<i>Towel rail and shelf supports</i>	
		Joint pour portes et pare douches	
		<i>Sealing strips for shower doors and screens</i>	
Pivots de sol et ferme-portes	P.165	Joint translucide à lèvres ou à bourrelet	P.264
<i>Floor springs and door closers</i>		<i>Translucent sealing strip with lips or compressor</i>	
Ferme-porte pour porte en verre DC500	P.63-166	Joint magnétiques	P.270
<i>Door closer for glass door DC500 series</i>		<i>Magnetic translucent sealing strips</i>	
Automatismes pour porte battante	P.19-167	Film antibuée pour miroir	P.274
<i>Swing door operators</i>		<i>Demisting film for mirror</i>	
Ferme-porte encastrable série 5600	P.168	Equipements pour vitrines, meubles et garde-corps	
<i>Overhead concealed door closer 5600 series</i>			
Pivots de sol série DC420	P.170		
<i>Floor springs DC420 series</i>			
Pivots de sol série DC450	P.174	Serrures de vitrine	P.276
<i>Floor springs DC450 series</i>		<i>Showcase lock</i>	
Pivots de sol série DC477	P.178	Pentures et pivots de vitrine	P.288
<i>Floor springs DC477 series</i>		<i>Showcase hinges and pivot clips</i>	
Pivots de sol série DC475	P.180	Pincés charnières et charnières à contreplaques pour vitrine	P.290
<i>Floor springs DC475 series</i>		<i>Clip hinges and wall plate hinges for showcases</i>	
Accessoires pour porte bois et métal	P.183	Pincés fixes pour vitrine	P.298
<i>Accessories for wooden and steel doors</i>		<i>Fixed clips for showcase</i>	
		Taquets de vitrine	P.300
Boutons et poignées de porte	P.185	<i>Showcases brackets</i>	
<i>Door knobs and handles</i>		Pincés de fixation et pieds à platine	P.302
		<i>Partition clips and plate stands</i>	
Systèmes pour Douches	P.197	Pattes à glaces, rosaces	P.306
<i>Shower systems</i>		<i>Mirror clips, rosettes</i>	
Slice	P.198	Pincés entretoises	P.307
Systèmes coulissants pour douches		<i>Clips</i>	
<i>Sliding shower system</i>		Supports de tablette	P.307
Eloa	P.200	<i>Shelf supports</i>	
Systèmes coulissants pour douches		Entretoises INOX pour plateau en verre	P.310
<i>Sliding shower system</i>		<i>Stainless steel spacer stands for glass table top</i>	
Filéo	P.210	Index numérique	P.314
Profil articulé pour pare baignoires		<i>Numerical index</i>	
<i>Hinged profile for bath screens</i>			
Profil articulé pour pare douches	P.212		
<i>Hinged profile for shower doors</i>			
Kubika	P.214		
Mélora	P.216		
Mélora SQ	P.220		
Marine	P.222		



Contrôle d'accès
Access control

ASSA ABLOY

shine™

Des performances exceptionnelles en matière de fermeture numérique pour portes en verre

Polished performance in digital locking for glass doors



Mode avancé

Le mode avancé peut être utilisé pour une gestion professionnelle et hautement sécurisée.

Advance mode

Advance mode can be used for professional and high security management.



Choix du mode d'accès

Pour votre confort, shine™ propose deux solutions d'accès, soit par code PIN soit par carte d'accès électronique.

Choice of access

shine™ has two access solutions, PIN code or RF Card key for your convenience.



Miroir magique

Grâce à l'option miroir magique, les chiffres n'apparaissent sur le pavé numérique à finition miroir qu'en cas de contact. Pour une sécurité optimale, l'utilisateur peut également utiliser le miroir pour regarder derrière lui avant de taper le code.

Magic mirror

With the magic mirror feature, the numbers appear on the mirror finish keypad only when it is touched. As an additional security feature, the user is able to check behind them using the mirror, before keying in the code.



Bouton tournant anti-effraction

Il est nécessaire de presser de part et d'autre du bouton tournant pour actionner le mécanisme. Ce dispositif de sécurité empêche toute « tentative d'infiltration » par les jeux de fonctionnement de la porte pour obtenir un accès non autorisé.

Anti-tamper thumbturn

Opposing buttons on grip of thumbturn require depressing to allow user to operate. This security feature prevents 'fishing' through the gap to gain unauthorised entry.



Fixation en cavalier (aucune encoche requise sur le verre)

Installation facile et rapide grâce au support à clip. Aucune encoche requise ; le support est fixé à l'aide d'un adhésif double-face extra-fort.

Clip type bracket (no drilling required)

Quick and easy installation with the clip bracket. No drilling required and the bracket is secured with strong double sided tape.



Design moderne et élégant

Clavier numérique robuste au design contemporain et discret.

Modern slim design

Robust, low profile contemporary digital keypad design.



Alarme haute température

En cas d'incendie, toute augmentation de la température intérieure sera détectée. L'alarme intégrée sera alors activée et le système de fermeture sera automatiquement déverrouillé.

High temperature alarm

In the case of fire, it will detect the increase in temperature on the inside. The in-built alarm will then be activated and the lock status released automatically.



Faux code PIN

Pour empêcher toute exposition du code PIN, vous avez la possibilité d'entrer de faux codes avant ou après avoir saisi votre code PIN.

Fake PIN code

To prevent the PIN code from being exposed, it allows you to enter fake numbers before or after entering your PIN code.



Commande à distance (option)

Une option de commande à distance est également disponible. Reposant sur la technologie Wireless Floating ID, elle a une portée de 50 mètres de distance.

Remote control (optional)

A remote control option is also available. Using Wireless Floating ID technology, it will work up to 50 metres.

LES + PRODUITS

The + product



Pour porte intérieure et extérieure

For interior and exterior door

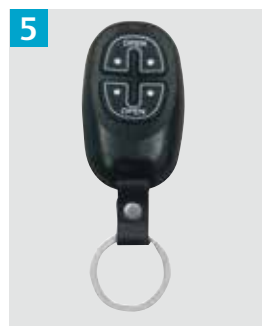
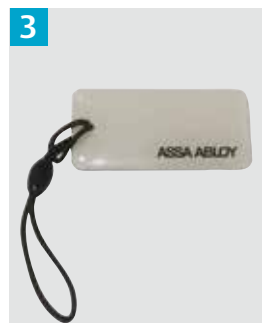



References

<p>1 </p>	<p>Serrure motorisée pour verre de 10-12 mm d'épaisseur Avant : 36 (P.) X 72 (l.) X 185 (H.) mm - Arrière : 13 (P.) X 66 (l.) X 179 (H.) mm <i>Motorised lock for 10-12mm glass</i> Front Body 36 (D) X 72 (W) X 185 (H) mm - Back Body 13 (D) X 66 (W) X 179 (H) mm • Livré avec une gâche plate, 4 badges magnétiques et 4 piles LR6 (AA) • Supplied with a flat keep, 4 magnetic tags and 4 LR6 (AA) batteries</p>	<p>SHINE.99</p>
<p>2 </p>	<p>Contre-boîtier pour serrure motorisée <i>Matching strike to fit for motorised lock</i></p>	<p>BGSHINE.99</p>
<p>3</p>	<p>Badge magnétique d'ouverture <i>Opening magnetic tag</i></p>	<p>TAGSHINE.99</p>
<p>4</p>	<p>Module pour télécommande <i>Module for remote control</i></p>	<p>MODSHINE</p>
<p>5</p>	<p>Télécommande <i>Remote control</i></p>	<p>TELESHINE</p>

Série 9700

BANDEAUX ELECTRIQUES SANS ENCOCHE

NOTCHLESS ELECTRIC MIDRAILS



LES + PRODUITS

The + product

Contrôle d'accès
intégré

Sans encoche

Integrated access
control

No notch

Caractéristiques techniques

- Ne nécessite aucune encoche
- Jeux mini entre les vantaux 3 mm
- Bandeaux réversibles à gâche électrique
- Bandeau équipé en série d'un ½ cylindre profil européen panneton DIN, d'une poignée de tirage et d'une plaque à pousser
- Protection du pêne ½ tour par cache
- Alimentation de la gâche électrique (12 volts DC 1 A)
- Pour verre trempé de 10 mm

Ouverture intérieure

- Ouverture électrique : décondamnation de la gâche électrique par bouton d'appel lumineux fixé sur le vantail semi-fixe du bandeau (en version double)
- Ouverture du mécanisme : par bouton tournant sur le vantail de service



Ouverture extérieure

- Ouverture électrique : par tous les systèmes compatibles avec gâche électrique. Lecteur de cartes, interphone, clavier électrique, etc...
- Ouverture du mécanisme : par clé

Option

- Clavier électronique sur vantail semi-fixe ou mural (réf 2858.10.V2)

Technical features

- Requires no notch
- Minimum space 3 mm between the glass panels
- Reversible midrails with electric keep
- Standard midrail equipped with a european profile half cylinder, pull handle and push plate
- Spring bolt protected by cover
- Supply to electric keep (12 volts DC 1 A)
- For 10 thick toughened glass

Inwards opening

- Electric opening electric keep released by illuminated button on the semi-fixed panel of the midrail (version glass to glass)
- Mechanical opening by turn button on the moving panel of the midrail

Outwards opening

- Electric opening by any system compatible with the electric keep, card reader, interphone, electronic keypad, etc...
- Mechanical opening with a key

Option

- Electronic keypad on semi fixed or wall panel (ref 2858.10.V2)

9701.**.4

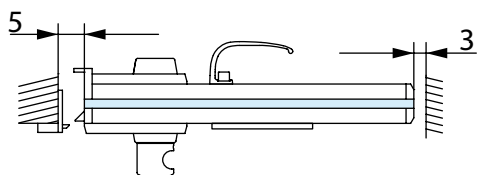

Aluminium anodisé argent satiné
Satin anodised alu. silver

Références / References



Bandeau électrique sans encoche 1 vantail (service)
Midrail for single moving door

9701.10.4

9702.**.4

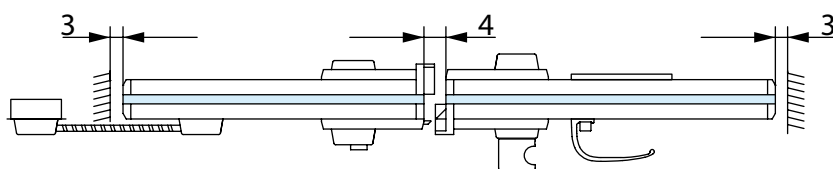

Aluminium anodisé argent satiné
Satin anodised alu. silver

Références / References



Bandeau électrique sans encoche 1 service et 1 semi-fixe
Midrail for 2 doors : 1 moving and 1 semi-fixed panel

9702.10.4

9703.**.4

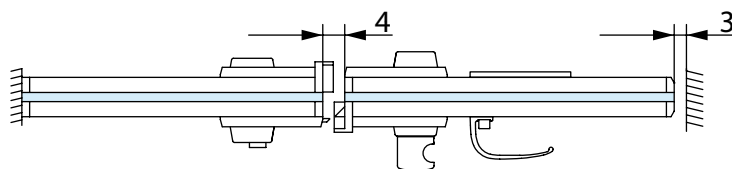

Aluminium anodisé argent satiné
Satin anodised alu. silver

Références / References



Bandeau électrique sans encoche 1 service et 1 fixe
Midrail for 2 panels : 1 moving and 1 fixed panel

9703.10.4

Contrôle d'accès
Access control

9704.**.4

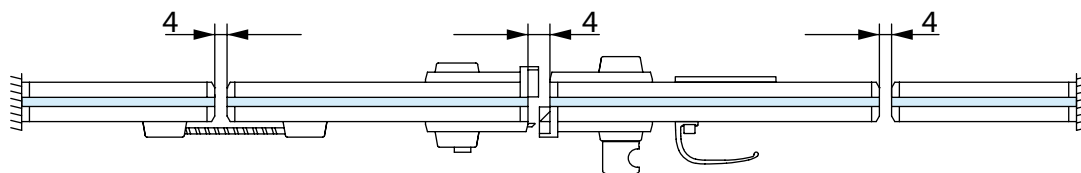

Références / References



Bandeau électrique sans encoche 1 service, 1 semi-fixe et 2 fixes
Midrail for 4 panels : 1 moving, 1 semi-fixed and 2 fixed panels



Aluminium anodisé argent satiné
Satin anodised alu. silver

9704.10.4



LES + PRODUITS
The + product

Sans encoche

No notch

9705.**.4

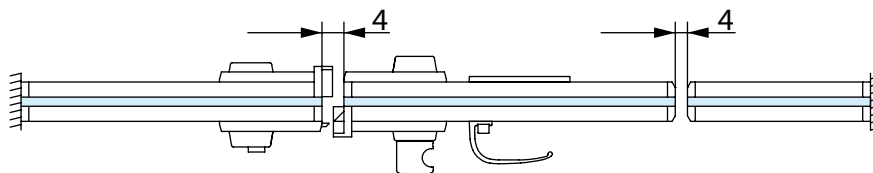

Références / References



Bandeau électrique sans encoche 1 service et 2 fixes
Midrail for 3 panels : 1 moving and 2 fixed panels



Aluminium anodisé argent satiné
Satin anodised alu. silver

9705.10.4

9706.**.4

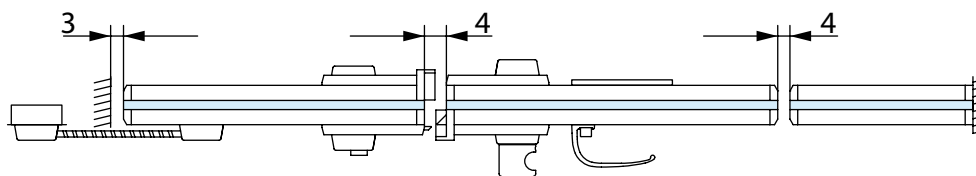

Références / References



Bandeau électrique sans encoche 1 service, 1 semi-fixe et 1 fixe
Midrail for 3 panels : 1 moving, 1 semi-fixed and 1 fixed panel



Aluminium anodisé argent satiné
Satin anodised alu. silver

9706.10.4

2858.10.V2

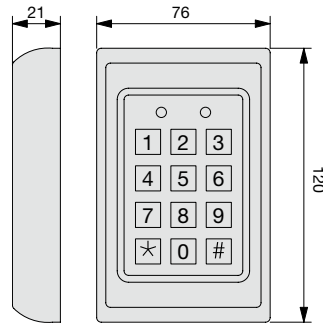

Contrôle d'accès
Access control

Clavier électronique argent, rétro éclairé
Electronic keypad silver, backlit

- Tension d'alimentation 12 à 24 volts alternatif ou continu
- Temporisation réglable de 1 à 17 secondes
- Pose en applique par 4 vis
- Clavier à touches lumineuses
- Résiste à l'eau et à la poussière
- 12 to 24 AC/DC power supply
- 1 to 17 second adjustable time delay
- Surface mounted with 4 screws
- Keypad with luminous keys
- Waterproof and dustproof

842.15

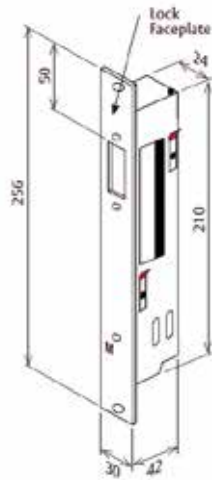

842/2.15



Inox Brossé
Brushed stainless steel

Références / References

Serrure motorisée électrique à cames à verrou V-lock
Motorized power cam-action bolt V-lock

842.15

Boîtier vide pour Serrure électrique pour situation verre-verre
Empty box for electric lock to glue onto the glass for glass to glass

842/2.15

- Fonction par rupture ou à émissions 12 ou 14 V
- Installation horizontale ou verticale
- Détecteur de position du verrou intégré
- Pour porte double action
- Gâche avec détection de porte intégrée
- Boîtier à coller avec cache pour porte en verre
- Utilisation avec pivot de sol conseillé
- Fail unlocked or switchable fail-locked function 12 or 14 V
- Horizontal and vertical mounting
- Integrated bolt position contact
- For double acting swing doors
- Strike plate with built in door detection
- Masonry box with screening plate for glass door
- Recommended use with floor springs

Contrôle d'accès Access control

Caractéristiques techniques

- Par rupture : la porte est ouverte en cas d'interruption de courant
- A émission : la porte reste fermée en cas d'interruption de courant
- 12 ou 24 Volts

Technical features

- Fail safe : power off, door unlocked
- Fail secure : power off, door is locked
- 12 or 24 Volt

17EDI.99

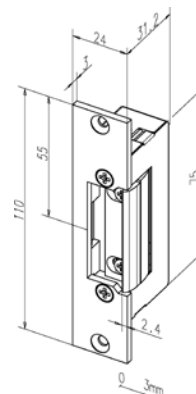

Références / References

Gâche électrique à volet réglable à émissions 6-12 v AC/DC avec décondamnation manuelle
Electric keep with adjustable flap 6-12 v with mechanical switch off

27DI.99

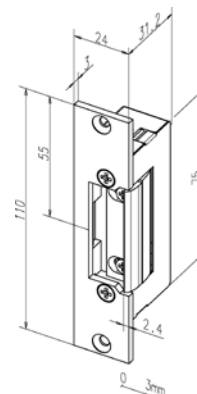

Références / References

Gâche électrique à volet réglable à émissions 6-12 v AC/DC avec mémoire (la porte reste ouverte après impulsion)
Electric keep with adjustable flap 6-12 v with memory (door remains unlocked after impulse)

37E9.99

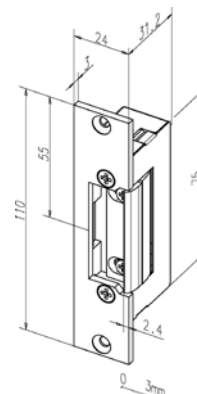

Références / References

Gâche électrique à volet réglable par rupture 12 v DC
Electric keep with adjustable flap with fail safe 12 v DC

14HZ.99

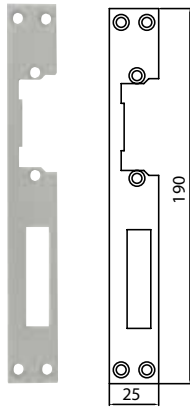

Contrôle d'accès
Access control

Références / References

Gâche plate pour série V360
Flat keep for V360 series

934.99

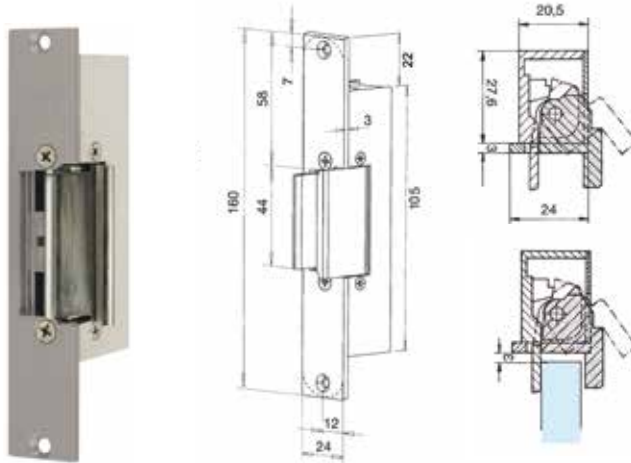

Références / References



Gâche électrique par rupture 12/24 v DC pour porte en verre 10-12 mm blocage de la porte verre directement par le volet de gâche
Electric keep with fail safe 12:24 v DC for 10-12 mm doors, doors blocked directly by strike flap



MAGC3000.99

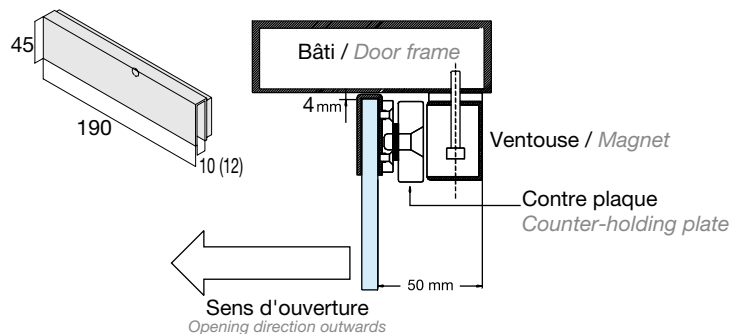

Références / References



Ventouse magnétique fonctionnement par rupture 12/24 V DC, avec cavalier pour verre 10-12 mm
Single magnetic contact fail safe 12/24 V DC, with clip-on U-plate for 10-12 mm

FRP02B/**.**.E

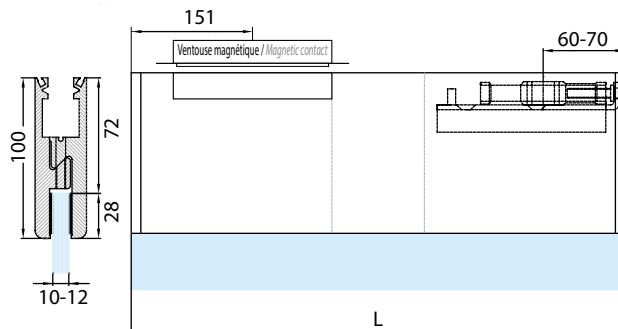
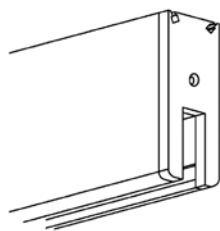

Références / References

Plinthe supérieure hauteur 100 mm avec insert, embouts et ventouse magnétique. Fonctionnement par rupture 24 V DC

Top rail 100 mm high with pivot block, end caps and single magnetic contact fail safe 24 V DC

Aluminium anodisé Argent Brossé
Brushed anodised alu. silver



Pour verre de 10 mm
For 10 mm glass

FRP02B/10.12.E



Pour verre de 12 mm
For 12 mm glass

FRP02B/12.12.E

- Force de maintien de 260 Kg
- Consommation de 62 mA
- Courant continue de 24 V

- Holding force 260 Kg
- Operation current de 62 mA
- Direct current de 24 V

FRP07B/**.**.E

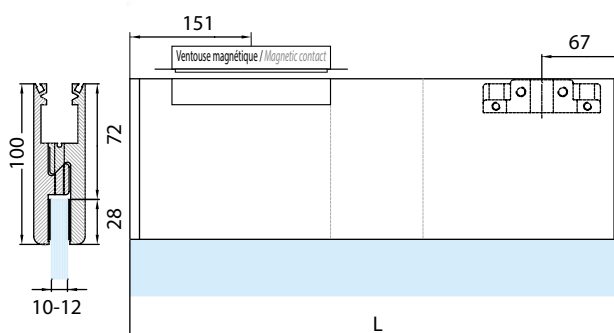
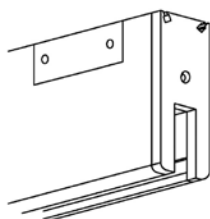

Références / References

Plinthe supérieure hauteur 100 mm avec ventouse et insert pour ferme porte encastré série 5600.

Fonctionnement par rupture 24 V DC

Top rail 100 mm high with single magnetic contact fail safe 24 V DC and pivot block for closers series 5600 and end caps

Aluminium anodisé Argent Brossé
Brushed anodised alu. silver



Pour verre de 10 mm
For 10 mm glass

FRP07B/10.12.E



Pour verre de 12 mm
For 12 mm glass

FRP07B/12.12.E

- Force de maintien de 260 Kg
- Consommation de 62 mA
- Courant continue de 24 V

- Holding force 260 Kg
- Operation current de 62 mA
- Direct current de 24 V



Contrôle d'accès
Access control

Code Handle Vertis



LES + PRODUITS
The + product

Sécurité
personnalisée

Personalised security

V360CHR.**

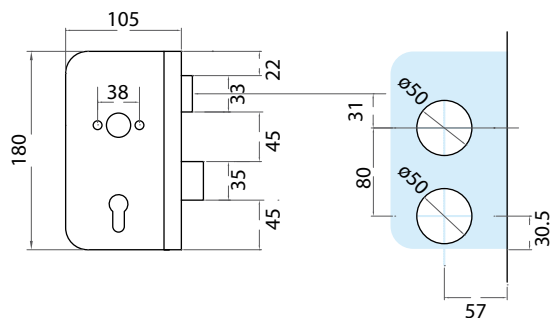
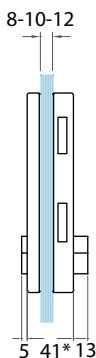
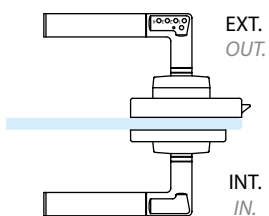

Références / References

*=10mm



Serrure avec poignées CODE HANDLE
Lock and CODE HANDLE

Aluminium anodisé argent brossé
Brushed anodised alu. silver

Inox Brossé
Brushed stainless steel

V360CHR.12

V360CHR.15

Livrée avec une gâche plate V2140.2.15
Supplied with strike plate V2140.2.15

V370CHL.**

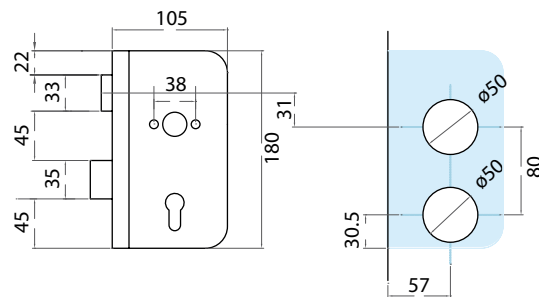
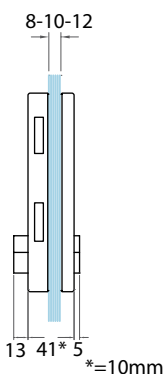
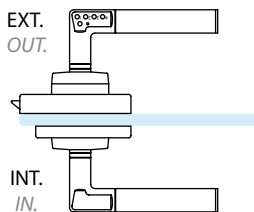

Références / References

*=10mm



Serrure avec poignées CODE HANDLE
Lock and CODE HANDLE

Aluminium anodisé argent brossé
Brushed anodised alu. silver

Inox Brossé
Brushed stainless steel

V370CHL.12

V370CHL.15

Livrée avec une gâche plate V2140.2.15
Supplied with strike plate V2140.2.15

Fonctionne en toute autonomie, avec seulement 2 piles (incluses dans la béquille).
Ne nécessite pas de câblage ou de réservation.
Prévient les risques d'enfermement par sa fonction de sortie toujours libre.
Inclue une fonction de verrouillage automatique au bout de 9 secondes.
Autonomie de 100000 manœuvres.
Indicateur de batterie faible : témoin lumineux clignotant en rouge à 500 manœuvres restantes.

Operating independently using only 2 batteries (included in the handle).
Does not require wiring or reservation.
It's function of allowing free exit prevents risk of being trapped.
Includes an automatic closure triggered after 9 seconds.
Independence for 100000 actions.
Indicator of low battery power: red intermittent light shows when 500 actions left.

V360CHL.**

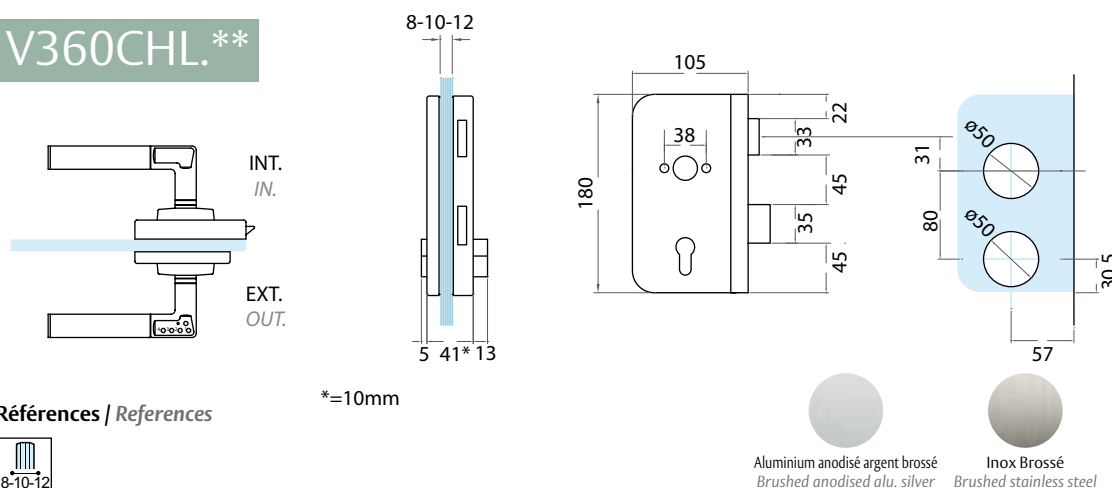

Références / References



Serrure avec poignées CODE HANDLE
Lock and CODE HANDLE

V360CHL.12

V360CHL.15

Livrée avec une gâche plate V2140.2.15
Supplied with strike plate V2140.2.15

V370CHR.**

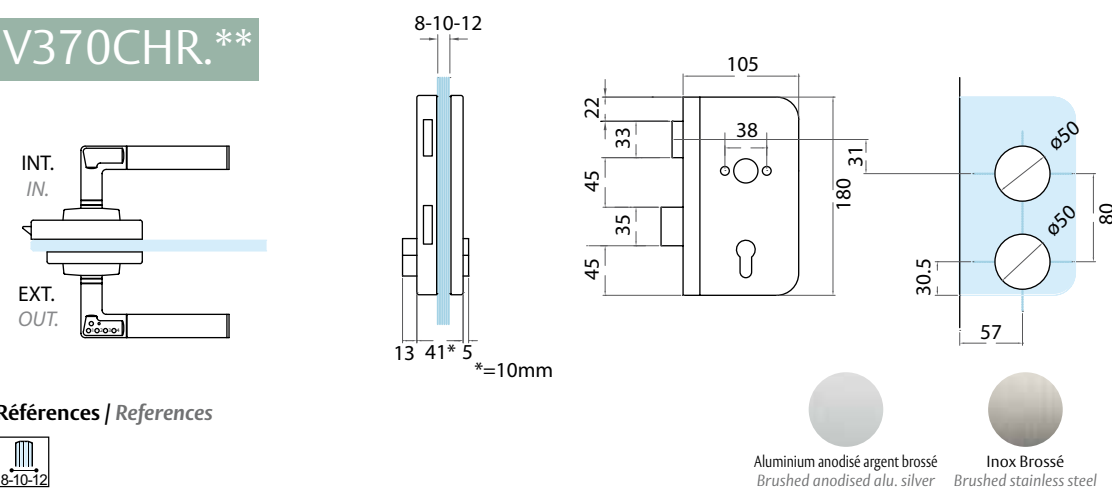

Références / References



Serrure avec poignées CODE HANDLE
Lock and CODE HANDLE

V370CHR.12

V370CHR.15

Livrée avec une gâche plate V2140.2.15
Supplied with strike plate V2140.2.15

Contrôle d'accès
Access control

Code Handle Lumira



LES + PRODUITS
The + product

Sécurité
personnalisée

Personalised security

V310CHOL.**

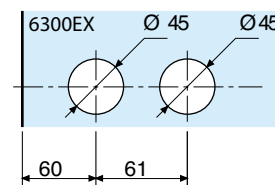
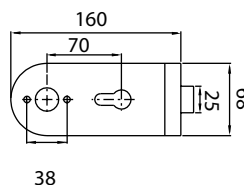
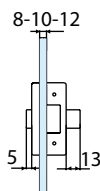
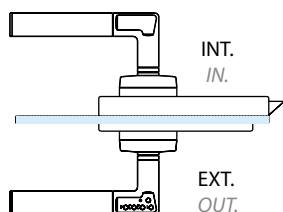

Références / References



Serrure de milieu avec poignées CODE HANDLE
Lock and CODE HANDLE



V310CHOL.12

V310CHOL.15

V310CHOR.**

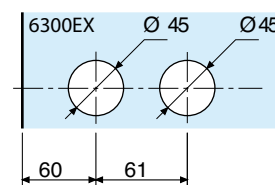
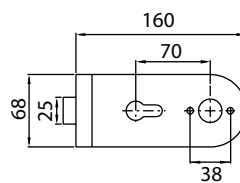
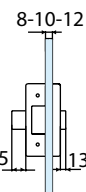
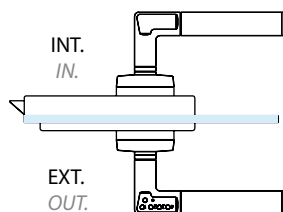

Références / References



Serrure de milieu avec poignées CODE HANDLE
Lock and CODE HANDLE



V310CHOR.12

V310CHOR.15



Portes Automatiques
Automatic doors

ASSA ABLOY

Portes
Automatiques
Automatic
doors

Slidematic

Slidematic

Caractéristiques techniques générales

- Automatisme pour porte coulissante intérieure pour porte simple ou double
- Opérateur pour porte battante en version tirer ou pousser
- Fonctionnement en tension basse alimentation intégrée
- Pour verre de 10 et 12 mm
- Possibilité de garder la position ouvert ou fermé avec un interrupteur
- Temporisateur réglable
- Usage bureau et résidentiel non intensif

General technical features

- Sliding door operators for interior or exterior applications for single or double doors
- Swing door operators in push or pull version
- Low voltage operating with integrated power supply
- For 10 and 12mm thick glass
- The Door Can Be Kept In Open Position (Or Closed Position) For A Longer Time With A Switch Of External Contact.
- Adjustable Hold Open
- Use office and residential non-intensive

LES + PRODUITS

The + product

Idéal pour personne
à mobilité réduite

*Ideal for
disabled people*



Porte simple
Single doors

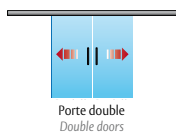

Porte double
Double doors



SLIDEMATIC1

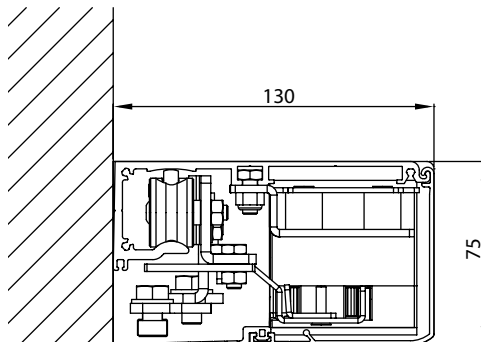

Aluminium anodisé argent brossé
Brushed anodised alu. silver

Références / References

Opérateur complet avec cache et embouts pour porte simple coulissante 'push and go'
Sliding door operator complete with cover and end caps for 'push and go' single door

SLIDEMATIC1.12

- Opérateur longueur 2200 mm recoupable
- Pour porte intérieure largeur maximum 1100 mm, ouverture maxi 1060 mm
- Poids maximum 60 kg
- Prévoir accessoires de fixation de porte SM02
- Operator length 2200 mm
- For maximum door width 1100 mm, max opening 1060 mm
- Maximum door weight 60 kg
- Fixing accessories for door SM02

SLIDEMATIC2

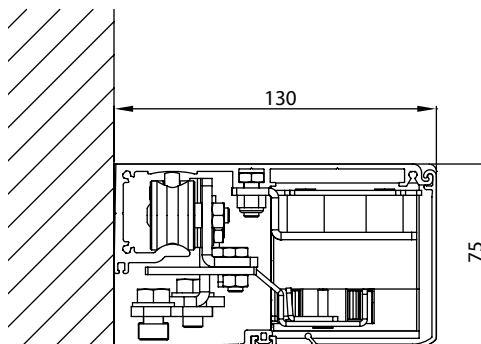

Aluminium anodisé argent brossé
Brushed anodised alu. silver

Références / References

Opérateur complet avec cache et embouts pour portes double coulissantes 'push and go'
Sliding door operator complete with cover and end caps for 'push and go' double doors

SLIDEMATIC2.12

- Opérateur longueur 3300 mm recoupable
- Pour 2 portes intérieures largeur maximum 840 mm, ouverture maxi 1600 mm
- Poids maximum 40 kg par porte
- Prévoir accessoires de fixation de porte SM02
- Operator length 3300 mm
- For maximum 2 doors width 840 mm, max opening 1600 mm
- Maximum door weight 40 kg per door
- Fixing accessories for door SM02

Accessoires Slidematic

Slidematic Accessories

SM02.12

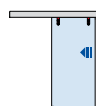
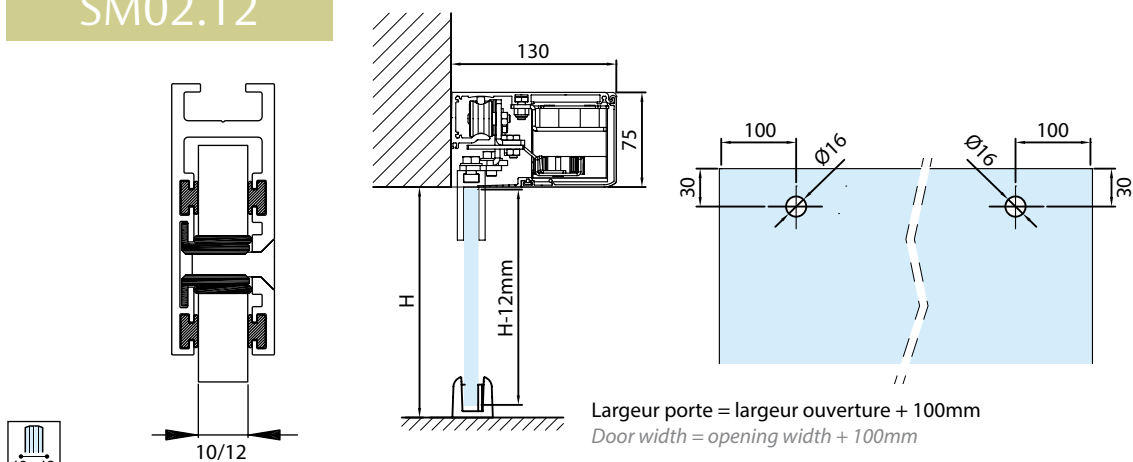

Profil aluminium anodisé argent pour 1 panneau coulissant, longueur 2 m
Aluminium profile for 1 glass panel, 2 m length silver anodised

- Livré avec 1 guide au sol.
- Supplied with 1 floor guide.

SM04.99



Radar 2 directions
Two way sensor

SM07.99

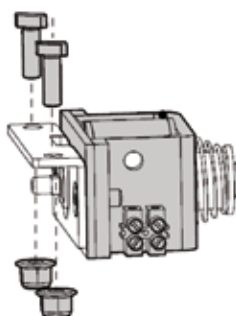

Verrou électro-mécanique pour SLIDEMATIC
Electro-mechanical lock for SLIDEMATIC

Ouvre-porte Autoswing

Autoswing door opener

Portes
Automatiques
Automatic
doors



AUTOSWING

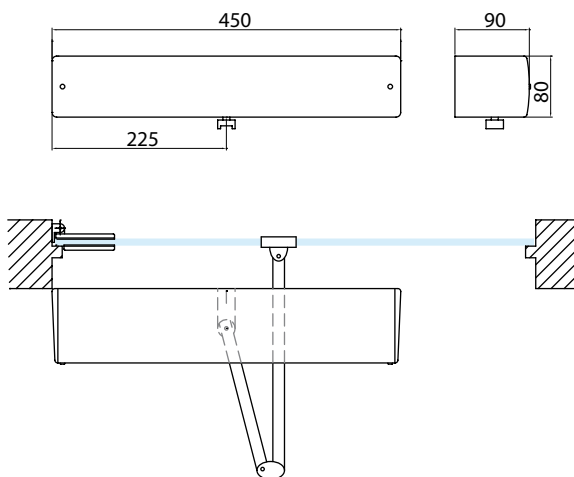

Références / References

AUTOSWING.73

Opérateur d'ouvre porte intérieur, complet avec cache, bras et cavalier pour porte en verre
Operator for single action interior door complete with cover and arm with clip-on U plate for glass door

Alimentation	230 V~ 50/60 Hz 24 V
Puissance consommée	120 W
Degré d'utilisation	Classe 5 - TRÈS INTENSE (600 cycles/jour)
Type de fonctionnement	Fermeture à moteur/Ouverture à moteur
Poids maximum pour 1 porte de largeur max 1000 mm	100 kg
Poids maximum pour 1 porte de largeur max 1200 mm	80 kg
Sortie moteur	24 V 3,5 A
Alimentation des accessoires	24 V 0,3 A

Power supply	230 V~ 50/60 Hz 24 V
Power consumption	120 W
Degree of use	Classe 5 - TRÈS INTENSE (600 cycles/jour)
Operation type	Fermeture à moteur/Ouverture à moteur
Maximum weight for 1 door width 1000 mm max	100 kg
Maximum weight for 1 door width 1200 mm max	80 kg
Motor power	24 V 3,5 A
Accessories power supply	24 V 0,3 A

Argent métallisé
Metallic silver





Systèmes pour portes
coulissantes en verre
Systems for sliding glass doors

ASSA ABLOY

Systèmes
pour portes
coulissantes
en verre

Systems for sliding
glass doors

Slice 60

Système ultra compact, avec dimensions réduites (50X60 mm), le SLICE s'intègre avec discrétion à tous types d'intérieurs :

- Roulement à billes pour minimiser le bruit,
- Amortisseurs hydrauliques en fin de course,
- Guide au sol avec patins.

Ultra compact system, with its slim line measurements (50X60 mm), SLICE fits with discretion into all types of interiors :

- Trolleys to decrease noise,
- Hydraulic shock absorbers,
- Special floor guide.

Références / References

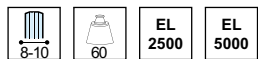

Kits complets / Complete Kits



Alu. anodisé argent brossé
Brushed anodised alu. silver



Alu. anodisé ANINOX
Brushed anodised alu. aninox



Laqué Blanc
Lacquered white

Système pour porte simple coulissante, rail lg 2500 mm
System for single sliding door, rail length 2500 mm

KSL60M1.12

KSL60M1.36

KSL60M1.51

Système pour porte double coulissante, rail lg 5000 mm
System for double sliding doors, rail length 5000 mm

KSL60M2.12

KSL60M2.36

KSL60M2.51

Références / References

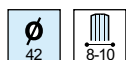

Anneau de tirage
Ring pull



Chromé brillant
Bright chromium



Chromé mat
Matt chromium

SL27.30

SL27.31

LES + PRODUITS

The + product

Pas d'encoche

Compact

Silencieux

No notch

Compact

Noiseless

Ce kit comprend

KSL60M1.**

- Un rail avec cache rail lg 2500 mm, 2 chariots avec pinces, 2 butées, 2 embouts, 1 guide au sol et 1 anneau de tirage SL27

KSL60M2.**

- Un rail avec cache rail lg 5000 mm, 4 chariots avec pinces, 4 butées, 2 embouts, 2 guides au sol et 2 anneaux de tirage SL27

This kit includes

KSL60M1.**

- One rail and cover length 2500 mm, 2 glass clamping trolleys, 2 stops, 2 end covers, 1 floor guide and 1 ring pull SL27

KSL60M2.**

- One rail and cover length 5000 mm, 4 glass clamping trolleys, 4 stops, 2 end covers, 2 floors guide and 2 ring pulls SL27

Caractéristiques techniques

- Poids maxi par porte : 60 kg
- Sans encoche
- Pour verre trempé de 8 et 10 mm (non fourni)
- Fixation au mur ou au plafond
- Rail : aluminium anodisé ou laqué RAL

Technical features

- Maximum door weight : 60 kg
- No notch required
- For 8 and 10 mm thick toughened glass (not supplied)
- Wall or ceiling installation
- Rail : Anodised aluminium or RAL lacquered finish

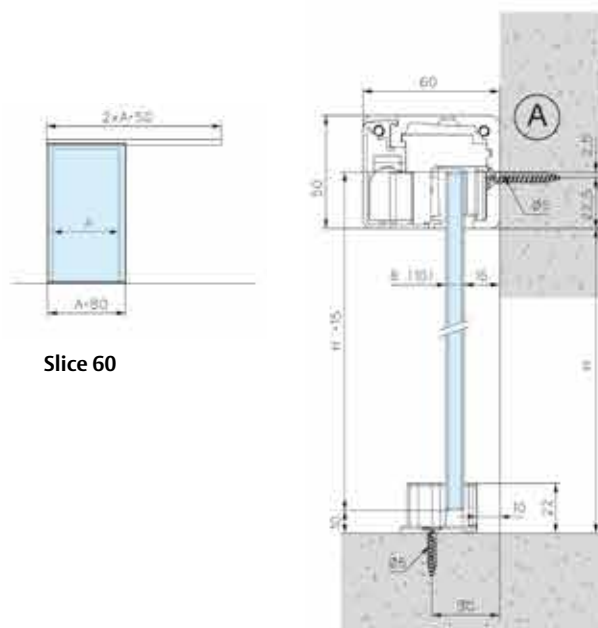

Slice 60

Idéal
pour l'intérieur
de la maison
Ideal for home
interiors

Slice Synchro

Ouverture et fermeture simultanée des deux portes grâce à la simple poussée d'une main !
Simultaneous opening of both doors by a simple movement with one hand

Systems
pour portes
coulissantes
en verre
Systems for sliding
glass doors



Références / References



Kits complets / Complete Kits



Alu. anodisé argent brossé
Brushed anodised alu. silver



Alu. anodisé ANINOX
Brushed anodised alu. aninox



Laqué Blanc
Lacquered white

Système synchronisé pour porte double coulissante, rail lg 5000 mm
Simultaneous opening system for double sliding doors, rail length 5000 mm

KSL560M2.12

KSL560M2.36

KSL560M2.51

Ce kit comprend

KSL560M2.**

- Un rail avec cache rail lg 5000 mm, 4 chariots avec pinces, 3 butées, 2 embouts, 2 guides au sol, 2 anneaux de tirage SL27 et un Kit synchronisation de porte

Caractéristiques techniques

- Poids maxi par porte : 60 kg
- Sans encoche
- Pour verre trempé de 8 et 10 mm (non fourni)
- Fixation au mur ou au plafond
- Rail : aluminium anodisé ou laqué RAL
- **Pour porte largeur mini 800 mm**

This kit includes

KSL560M2.**

- One rail and cover length 5000 mm, 4 glass clamping trolleys, 3 stops, 2 end covers, 2 floors guide, 2 ring pulls SL27 and a doors synchronisation Kit

Technical features

- Maximum door weight : 60 kg
- No notch required
- For 8 and 10 mm thick toughened glass (not supplied)
- Wall or ceiling installation
- Rail : Anodised aluminium or RAL lacquered finish
- **Minimum door width : 800 mm**

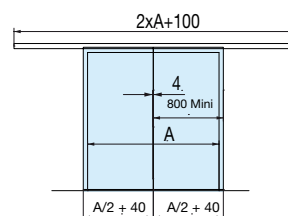
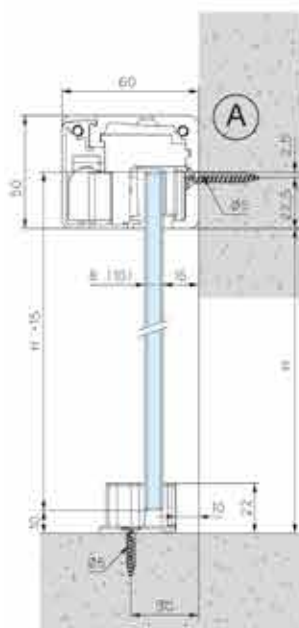

Slice Synchro

Systèmes
pour portes
coulissantes
en verre
*Systems for sliding
glass doors*

Slice 60

Références / References

EL
5000

Rail et profil / Rail and profile

	Alu. anodisé argent brossé <i>Brushed anodised alu. silver</i>	Alu. anodisé ANINOX <i>Brushed anodised alu. aninox</i>	Laqué Blanc <i>Lacquered white</i>
Rail + capot coulissant SLICE <i>Rail and cover SLICE</i>	SL10.12	SL10.36	SL10.51
Rail + capot coulissant SLICE et volume fixe ep. 8 et 10 mm <i>Rail and cover SLICE and fixed panels, for 8 and 10 mm glass</i>	SL15/10.12	SL15/10.36	SL15/10.51
Rail + capot coulissant SLICE et volume fixe ep. 12 mm <i>Rail and cover SLICE and fixed panels, for 12 mm glass</i>	SL15/12.12	SL15/12.36	SL15/12.51
Profil U 15x15x15x2 pour volume fixe ep. 8mm <i>U-profile 15x15x15x2 for fixed panels, for 8 mm glass</i>	U151515.12	U151515.36	U151515.51
Profil U 20x20x20x2 pour volume fixe ep. 10 et 12mm <i>U-profile 20x20x20x2 for fixed panels, for 10 and 12 mm glass</i>	U202020.12	U202020.36	U202020.51



Kit Chariots / Trolley Kit

kit de 2 chariots avec pince, 1 guide au sol, 2 arrêts <i>Kit of 2 glass clamping trolleys with 1 floor guide, 2 stops</i>	SL60.99
kit de 4 chariots avec pinces pour 2 portes synchro, 2 guides au sol, 3 arrêts <i>Kit of 4 glass clamping trolleys for 2 panels synchro with 2 floor guides, 3 stops</i>	SLS60M2.99
Guide au sol réglable pour verre 8/10 mm <i>Adjustable floor guide for 8/10 mm glass</i>	SL600.99

Poignées, boutons, serrures : voir page accessoires / *Handles, knobs, locks : see page accessories*

Paire d'embouts / End covers

	Argent métallisé <i>Metallic silver</i>	Effet INOX <i>Stainless steel effect</i>	Laqué Blanc <i>Lacquered white</i>
Paire d'embouts pour rail SL10. <i>Set of 2 end covers for rail SL10.</i>	SL195.12	SL195.36	SL195.51

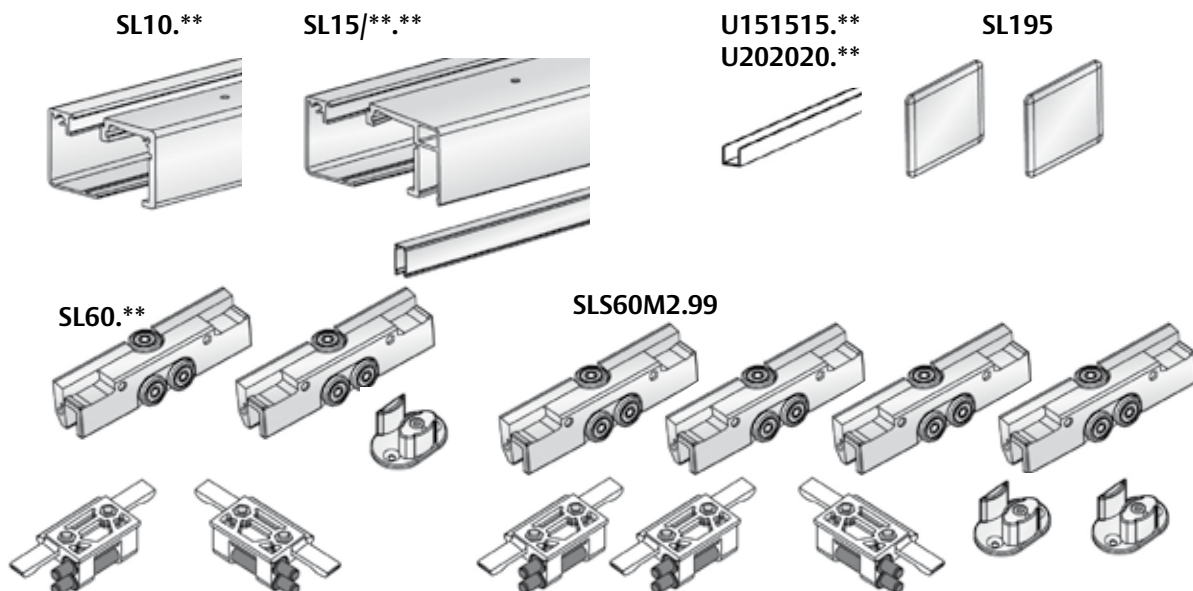
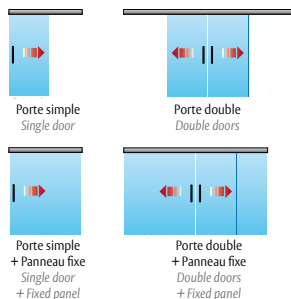

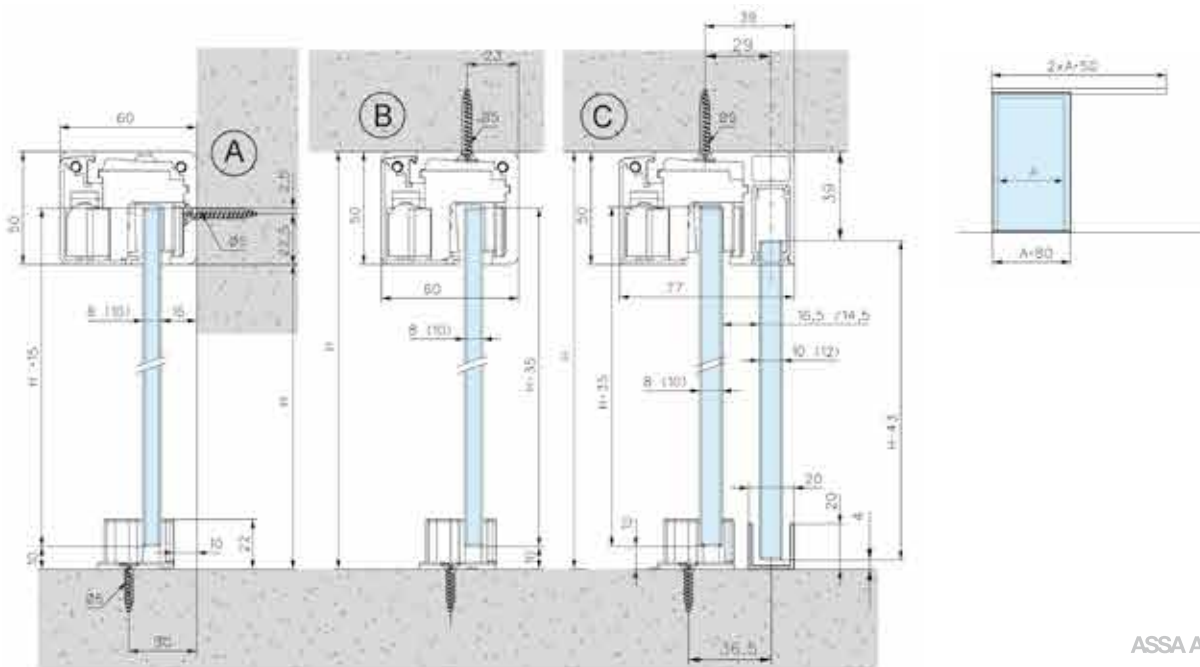

Systèmes
pour portes
coulissantes
en verre
*Systems for sliding
glass doors*

Slice 100

Système ultra compact, avec dimensions réduites (50X60 mm), le SLICE s'intègre avec discrétion à tous types d'intérieurs :

- Roulement à billes pour minimiser le bruit,
- Amortisseurs hydrauliques en fin de course,
- Guide au sol avec patins.

Ultra compact system, with its slim line measurements (50X60 mm), SLICE fits with discretion into all types of interiors :

- *Trolleys to decrease noise,*
- *Hydraulic shock absorbers,*
- *Special floor guide.*



LES + PRODUITS

The + product

Pas d'encoche

Compact

Silencieux

Spécial grande
ouverture

No notch

Compact

Noiseless

*Perfect for
large opening*

Références / References



Kit complet / Complete Kit



Alu. anodisé argent brossé
Brushed anodised alu. silver



Alu. anodisé ANINOX
Brushed anodised alu. aninox



Laqué Blanc
Lacquered white

Système pour porte simple coulissante, rail lg 5000 mm
System for single sliding door, rail length 5000 mm

KSL100M1.12

KSL100M1.36

KSL100M1.51

Système pour porte double coulissante, rail lg 5000 mm
System for double sliding doors, rail length 5000 mm

KSL100M2.12

KSL100M2.36

KSL100M2.51

Références / References

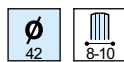

Anneau de tirage
Ring pull



Chromé brillant
Bright chromium



Chromé mat
Matt chromium

SL27.30

SL27.31



Porte simple
Single door

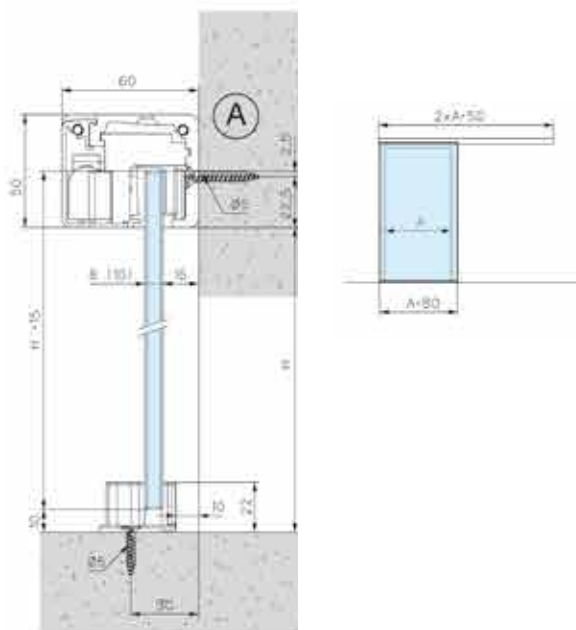

*Idéal
pour l'intérieur
de la maison
Ideal for home
interiors*



Ce kit comprend

- Un rail avec cache rail lg 5000 mm, 2 chariots avec pinces, 2 butées, 2 embouts, 1 guide au sol et 1 anneau de tirage SL27

This kit includes

- *One rail and cover length 5000 mm, 2 glass clamping trolleys with 2 stops, 2 end covers, 1 floor guide and 1 ring pull SL27*

Caractéristiques techniques

- Poids maxi par porte : 100 kg
- Sans encoche
- Pour verre trempé de 8 et 10 mm (non fourni)
- Fixation au mur ou au plafond
- Rail : aluminium anodisé ou laqué RAL

Technical features

- *Maximum door weight : 100 kg*
- *No notch required*
- *For 8 and 10 mm thick toughened glass (not supplied)*
- *Wall or ceiling installation*
- *Rail : Anodised aluminium or RAL lacquered finish*

Systemes
pour portes
coulissantes
en verre
*Systems for sliding
glass doors*

Slice 100

Références / References

EL
5000

Rail et profil / Rail and profile

	Alu. anodisé argent brossé <i>Brushed anodised alu. silver</i>	Alu. anodisé ANINOX <i>Brushed anodised alu. aninox</i>	Laqué Blanc <i>Lacquered white</i>
Rail + capot coulissant SLICE <i>Rail and cover plate SLICE</i>	SL10.12	SL10.36	SL10.51
Rail + capot coulissant SLICE et volume fixe ep. 8 et 10 mm <i>Rail and cover SLICE and fixed panels, for 8 and 10 mm glass</i>	SL15/10.12	SL15/10.36	SL15/10.51
Rail + capot coulissant SLICE et volume fixe ep. 12 mm <i>Rail and cover SLICE and fixed panels, for 12 mm glass</i>	SL15/12.12	SL15/12.36	SL15/12.51
Profil U 15x15x15x2 pour volume fixe ep. 8mm <i>U-profile 15x15x15x2 for fixed panels, for 8 mm glass</i>	U151515.12	U151515.36	U151515.51
Profil U 20x20x20x2 pour volume fixe ep. 10 et 12mm <i>U-profile 20x20x20x2 for fixed panels, for 10 and 12 mm glass</i>	U202020.12	U202020.36	U202020.51



Kit Chariots / Trolley Kit

kit de 2 chariots avec pince, 1 guide au sol, 2 arrêts <i>Kit of 2 glass clamping trolleys with 1 floor guide, 2 stops</i>	SL100.99
Guide au sol pour porte coulissante <i>Adjustable floor guide for sliding doors</i>	SL600.99

Poignées, boutons, serrures : voir page accessoires / *Handles, knobs, locks : see page accessories*

Paire d'embouts / End covers

	Argent métallisé <i>Metallic silver</i>	Effet INOX <i>Stainless steel effect</i>	Laqué Blanc <i>Lacquered white</i>
Paire d'embouts pour rail SL10. <i>Set of 2 end covers for rail SL10.</i>	SL195.12	SL195.36	SL195.51

LES + PRODUITS

The + product

Pas d'encoche

Compact

Silencieux

Spécial grande
ouverture

No notch

Compact

Noiseless

Perfect for
large opening

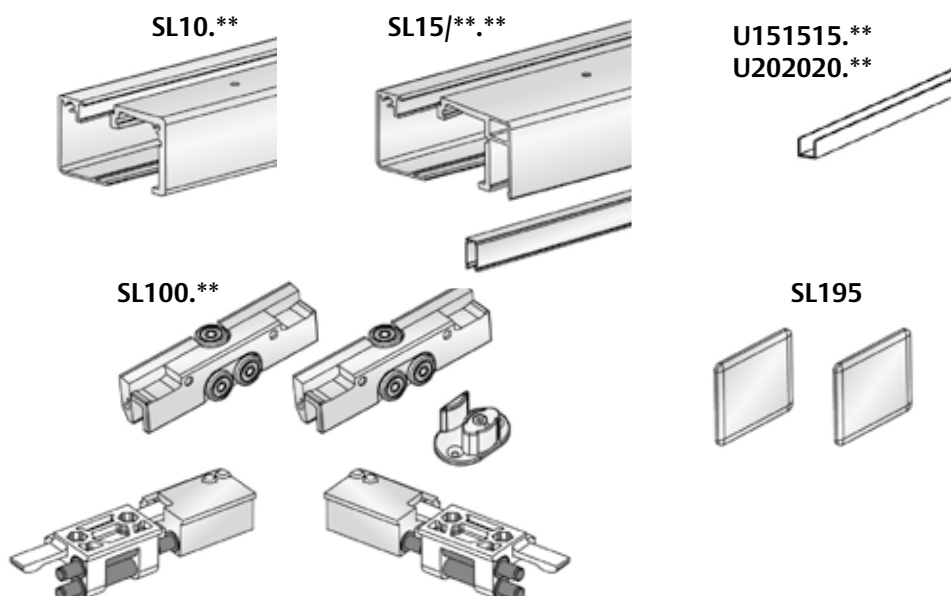
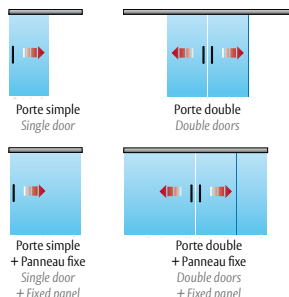

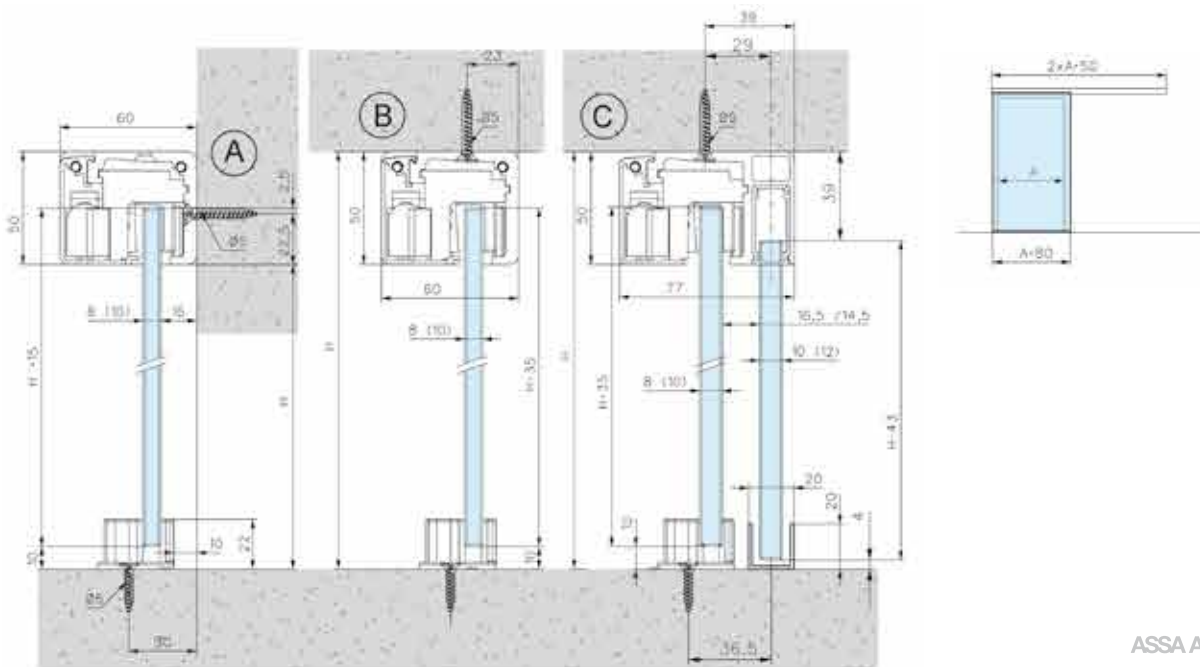

Systèmes
pour portes
coulissantes
en verre
Systems for sliding
glass doors

Slice Automove



- Amortisseur pour plus de sécurité et de confort
- Fermeture automatique sur les derniers 110 mm
- Simplicité de montage
- Réglage facile
- Montage sans encoche
- Pour porte maxi 80 kg
- Même longueur de rail avec ou sans automove
- Largeur de porte mini = (Hauteur ÷ 2.5)

- Cushioning of movement for more safety and comfort
- Automatic closing in the last 110 mm
- Easy to pose
- Simple to adjust
- Assembly without notches
- Maximum weight per door 80 kg
- Same rail length with or without automove
- Minimum door width = (Height ÷ 2.5)

5 ans de garantie

Testé à plus
de 100 000
manœuvres

5 years guarantee

Tested more than
100 000 cycles

Références / References



Kit complet / Complete Kit



Alu. anodisé argent brossé
Brushed anodised alu. silver



Alu. anodisé ANINOX
Brushed anodised alu. aninox



Laqué Blanc
Lacquered white

Système pour porte simple coulissante rail lg 2500 mm,
avec 1 amortisseur Automove, 1 arrêt.

System for single sliding door, rail length 2500 mm, with 1 Automoves, 1 stop.

KSL81M1.12

KSL81M1.36

KSL81M1.51

Système pour porte double coulissante rail lg 5000 mm,
avec 2 amortisseurs Automove, 2 arrêts.

System for double sliding door rail length 5000 mm, with 2 Automoves, 2 stops.

KSL81M2.12

KSL81M2.36

KSL81M2.51

Système pour porte simple coulissante rail lg 2500 mm,
avec 2 amortisseurs Automove.

System for single sliding door, rail length 2500 mm, with 2 Automoves.

KSL82M1.12

KSL82M1.36

KSL82M1.51

Système pour porte double coulissante rail lg 5000 mm,
avec 4 amortisseurs Automove.

System for double sliding door, rail length 5000 mm, with 4 Automoves.

KSL82M2.12

KSL82M2.36

KSL82M2.51

Références / References

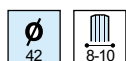

Anneau de tirage
Ring pull



Chromé brillant
Bright chromium



Chromé mat
Matt chromium

SL27.30

SL27.31





Ce kit comprend

KSL81M1.**

- Un rail avec cache rail lg 2500 mm, 2 chariots avec pinces, 1 butée automove, 1 butée, 2 embouts, 1 guide au sol et 1 anneau de tirage SL27

KSL81M2.**

- Un rail avec cache rail lg 5000 mm, 2 chariots avec pinces, 2 butées automove, 2 butées, 2 embouts, 2 guides au sol et 2 anneaux de tirage SL27

KSL82M1.**

- Un rail avec cache rail lg 2500 mm, 2 chariots avec pinces, 2 butées automove, 2 embouts, 1 guide au sol et 1 anneau de tirage SL27

KSL82M2.**

- Un rail avec cache rail lg 5000 mm, 2 chariots avec pinces, 4 butées automove, 2 embouts, 2 guides au sol et 2 anneaux de tirage SL27

Caractéristiques techniques

- Poids maxi par porte : 80 kg
- Sans encoche
- Pour verre trempé de 8 et 10 mm (non fourni)
- Fixation au mur ou au plafond
- Rail : aluminium anodisé ou laqué RAL
- Largeur de porte mini = (Hauteur ÷ 2.5)

This kit includes

KSL81M1.**

- One rail and cover length 2500 mm, 2 glass clamping trolleys with 1 stop, 1 automove, 2 end covers, 1 floor guide and 1 ring pull SL27

KSL81M2.**

- One rail and cover length 5000 mm, 2 glass clamping trolleys with 2 stops, 2 automoves, 2 end covers, 2 floor guides and 2 rings pull SL27

KSL82M1.**

- One rail and cover length 2500 mm, 2 glass clamping trolleys with 2 automoves, 2 end covers, 1 floor guide and 1 ring pull SL27

KSL82M2.**

- One rail and cover length 5000 mm, 2 glass clamping trolleys with 4 automoves, 2 end covers, 2 floor guides and 2 rings pull SL27

Technical features

- Maximum door weight : 80 kg
- No notch required
- For 8 and 10 mm thick toughened glass (not supplied)
- Wall or ceiling installation
- Rail : Anodised aluminium or RAL lacquered finish
- Minimum door width = (Height ÷ 2.5)

Systèmes
pour portes
coulissantes
en verre
*Systems for sliding
glass doors*

Slice Automove

Références / References

EL
5000

Rail et profil / Rail and profile



Alu. anodisé argent brossé
Brushed anodised alu. silver



Alu. anodisé ANINOX
Brushed anodised alu. aninox



Laqué Blanc
Lacquered white

Rail + capot coulissant SLICE

Rail and cover SLICE

SL10.12

SL10.36

SL10.51

Rail + capot coulissant SLICE et volume fixe ep. 8 et 10 mm

Rail and cover SLICE and fixed panels, for 8 and 10 mm glass

SL15/10.12

SL15/10.36

SL15/10.51

Rail + capot coulissant SLICE et volume fixe ep. 12 mm

Rail and cover SLICE and fixed panels, for 12 mm glass

SL15/12.12

SL15/12.36

SL15/12.51

Profil U 15x15x15x2 pour volume fixe ep. 8mm

U-profile 15x15x15x2 for fixed panels, for 8 mm glass

U151515.12

U151515.36

U151515.51

Profil U 20x20x20x2 pour volume fixe ep. 10 et 12mm

U-profile 20x20x20x2 for fixed panels, for 10 and 12 mm glass

U202020.12

U202020.36

U202020.51



Kit Chariots / Trolley Kit

kit de 2 chariots avec pince, 1 guide au sol, 1 amortisseur Automove et 1 butée.

Kit of 2 glass clamping trolley with 1 floor guide, 1 Automove and 1 stop.

SL81.99

kit de 2 chariots avec pince, 1 guide au sol, 2 amortisseurs Automove.

Kit of 2 glass clamping trolley with 1 floor guide, 2 Automoves.

SL82.99

Guide au sol réglable pour verre 8/10 mm

Adjustable floor guide for 8/10 mm glass

SL600.99

Poignées, boutons, serrures : voir page accessoires / Handles, knobs, locks : see page accessories

Paire d'embouts / End covers



Argent métallisé
Metallic silver



Effet INOX
Stainless steel effect



Laqué Blanc
Lacquered white

Paire d'embouts pour rail SL10.

Set of 2 end covers for rail SL10.

SL195.12

SL195.36

SL195.51

SL10.**

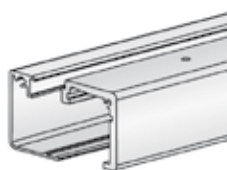

SL15/**.**

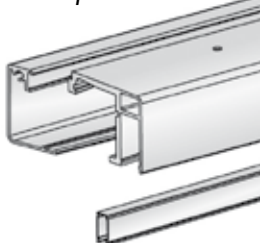

U151515.**
U202020.**



SL195



SL81.**

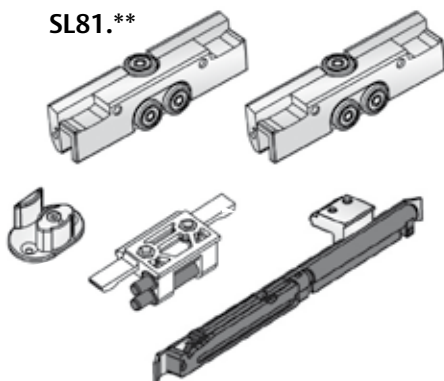

SL82.**

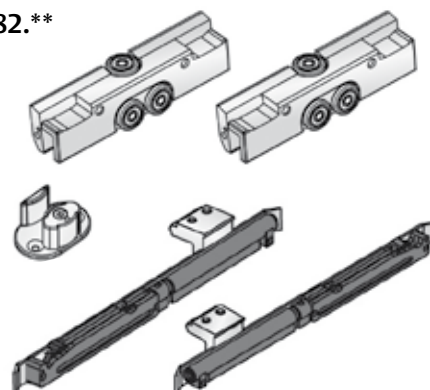

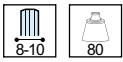

Kit Chariots / Trolley Kit

kit de 2 chariots avec pince, 1 guide au sol, 1 amortisseur Automove et 1 butée.
Kit of 2 glass clamping trolley with 1 floor guide, 1 Automove and 1 stop.

SL81.99

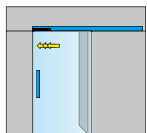

1 x SL10.** + 1 x SL81.99
+ SL195.**

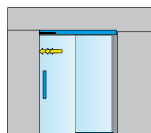

1 x SL15.** + 1 x SL81.99 + Profil U



1 x SL10.** + 2 x SL81.99
+ SL195.**



1 x SL15.** + 2 x SL81.99 + Profil U



Kit Chariots / Trolley Kit

kit de 2 chariots avec pince, 1 guide au sol, 2 amortisseurs Automove.
Kit of 2 glass clamping trolley with 1 floor guide, 2 Automoves.

SL82.99

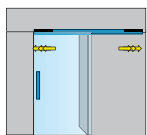

1 x SL10.** + 1 x SL82.99
+ SL195.**

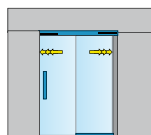

1 x SL15.** + 1 x SL82.99 + Profil U

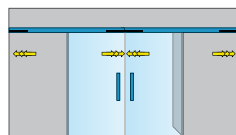

1 x SL10.** + 2 x SL82.99
+ SL195.**



1 x SL15.** + 2 x SL82.99 + profil U

Poignées, boutons, serrures : voir page accessoires / Handles, knobs, locks : see page accessories

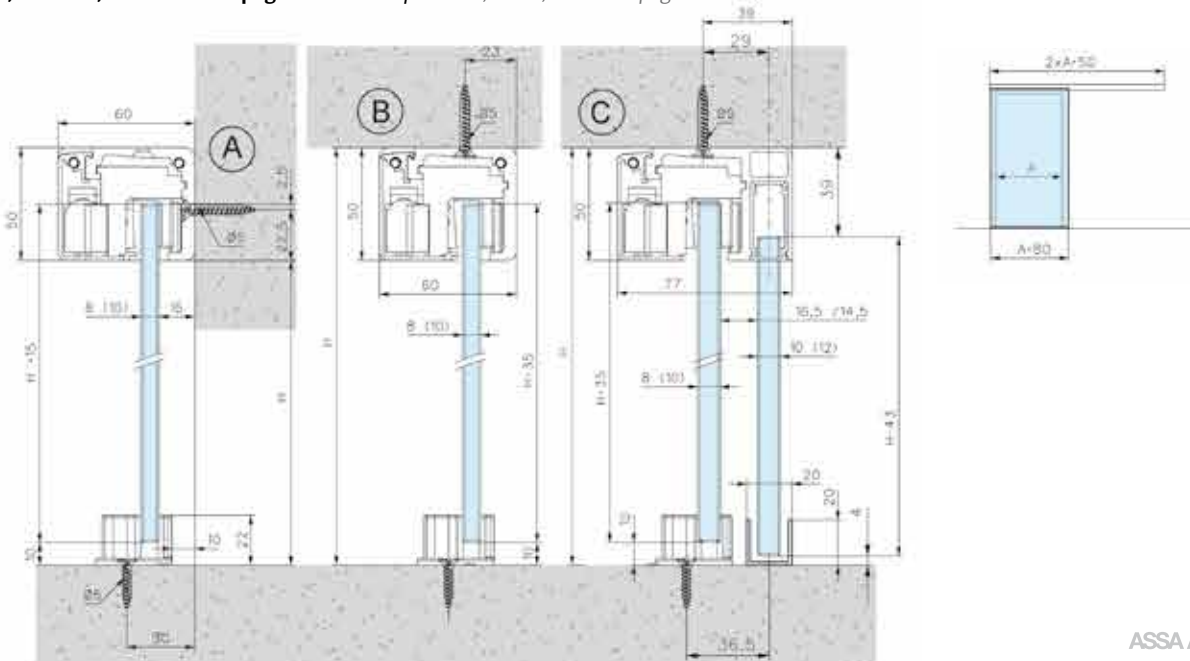

Systèmes
pour portes
coulissantes
en verre
*Systems for sliding
glass doors*

Magic Slide

Système coulissant invisible
Concealed sliding system



LES + PRODUITS

Système invisible :
pas de rail
sur le mur

Installation facile

Coulissant réversible
droite ou gauche

*Invisible system :
no profile on the wall*

Easy installation

Reversible right or left

Références / References



Kit complet



Alu. anodisé argent brossé
Brushed anodised alu. silver

Système pour porte simple coulissante réversible droite ou gauche
System for single sliding door reversible right or left

MSL80M1.12

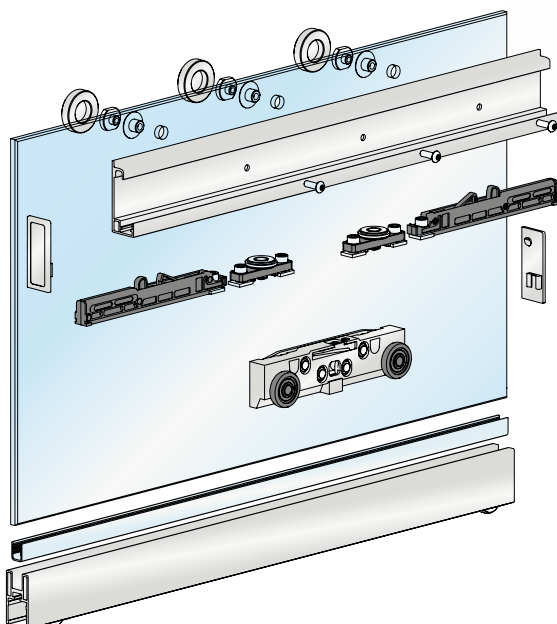
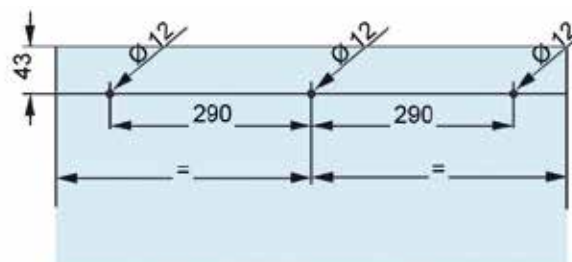

Ce kit comprend

- Un profil haut et bas en finition anodisé argent
- Un guide au sol
- 2 amortisseurs intégrés dans le mécanisme
- 2 roulettes intégrées dans le profil bas
- Des vis et cache-vis anodisés pour la fixation du verre sur le profil haut

This kit includes

- Top and bottom rail available in silver anodized finish
- A floor guide
- 2 Stops integrated into top rail
- 2 trolleys integrated into bottom rail
- Screws and anodized screw covers to assemble glass onto the top rail

3 Types d'installation / 3 Types of installation

Systèmes pour portes coulissantes en verre
Systems for sliding glass doors

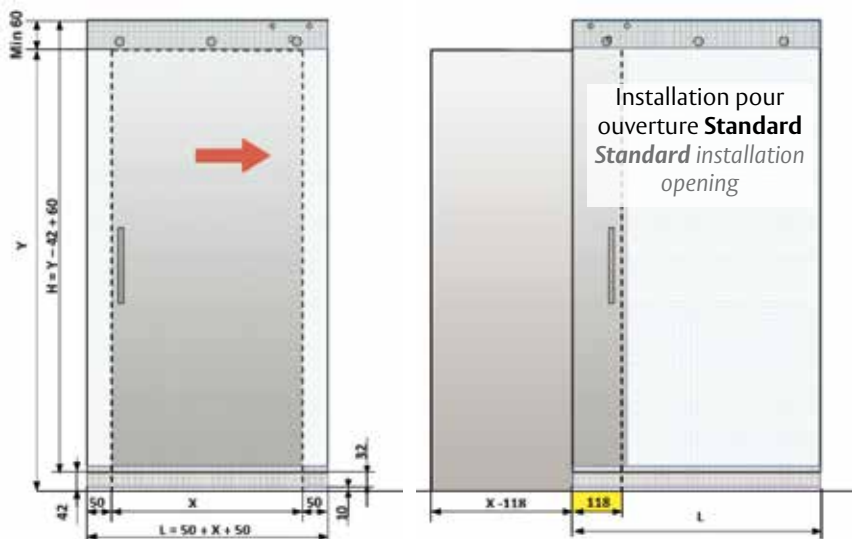

Caractéristiques techniques

- Recommandé pour porte intérieure
- Largeur de porte maxi 1100 mm
- Poids maxi par porte : 80 kg
- Pour verre trempé de 8 mm (non fourni)
- Fixation en applique sur linéau
- Mécanisme invisible
- Amortisseurs pour plus de sécurité et confort
- Système réversible droite ou gauche
- Montage sur 3 trous Ø 12 mm

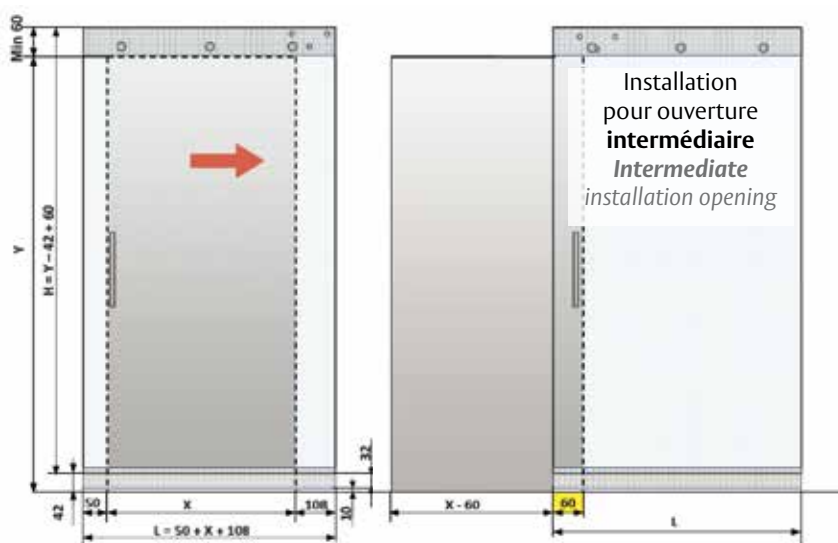

Technical features

- Recommended for inside doors
- Maximum door width 1100 mm
- Maximum door weight : 80 kg
- For 8mm thick toughened glass (not supplied)
- Wall mounted
- Invisible mechanism
- Cushioning of movement for safety and comfort
- Reversible system right or left
- Assembled onto 3 holes Ø 12 mm

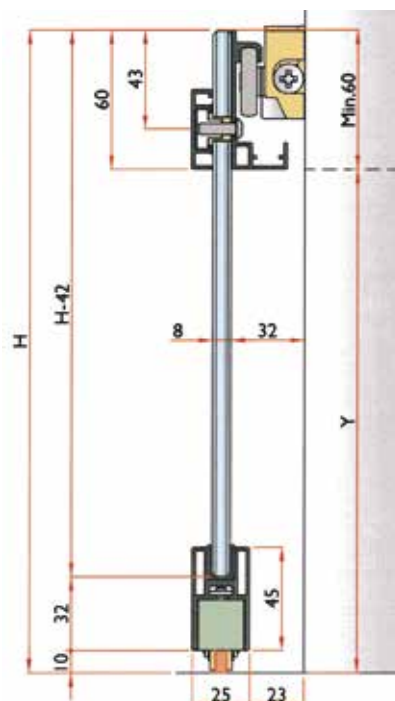
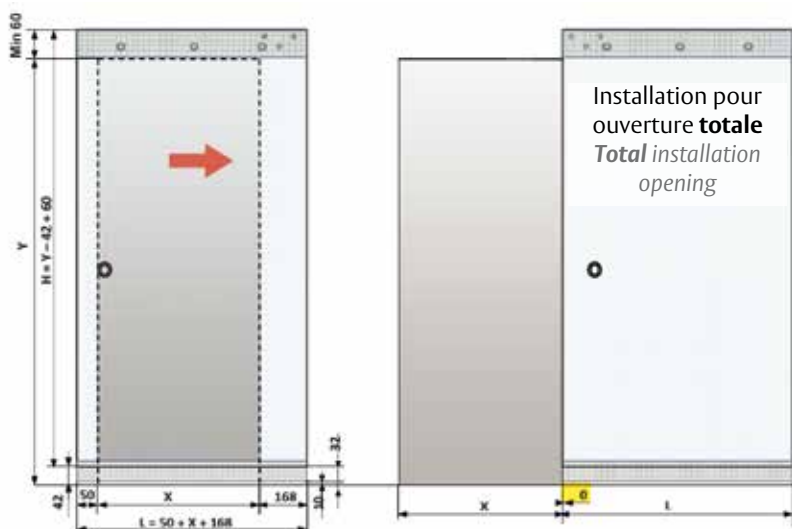

Systèmes
pour portes
coulissantes
en verre
*Systems for sliding
glass doors*

Cilindric Automove

Système pour porte coulissante en verre à fermeture automatique
System for sliding glass doors with automatic closing

Les lignes modernes et épurées du système Cilindric intègrent les innovations technologiques Assa Abloy Glass, facilitant la pose et apportant un grand confort d'utilisation.

Cilindric's modern and purified lines integrate the latest technological innovations, facilitating the installation and bringing convenience to the end user.

Caractéristiques techniques

- Amortisseur pour plus de sécurité et de confort
- Fermeture automatique sur les derniers 75 mm
- Recommandé pour porte intérieure
- Largeur de porte maxi 1100 mm
- Poids maxi par porte : 80 kg
- Pour verre trempé de 8 ou 10 mm (non fourni)
- Fixation en applique
- Système réversible droite ou gauche
- Montage sur 4 trous Ø 26 mm
- Garantie 5 ans

Technical features

- Cushioning of movement for safety and comfort
- Automatic closing in the last 75 mm
- Recommended for inside doors
- Maximum door width 1100 mm
- Maximum door weight : 80 kg
- For 8-10 mm thick toughened glass (not supplied)
- Wall mounted
- Reversible system right or left
- Assembled onto 4 holes Ø 26 mm
- 5 years warranty

LES + PRODUITS

The + product

Inox brossé

Fermeture
automatique

Testé à plus
de 100 000
manœuvres

Brushed
stainless steel

Automatic closing

Tested more
than 100 000 cycles

Références / References

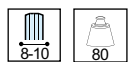

Système pour porte simple coulissante rail lg 2000 mm, avec 2 amortisseurs Automove.
System for single sliding door, rail length 2000 mm, with 2 Automoves.



CISL82M1.15



Porte simple
Single doors

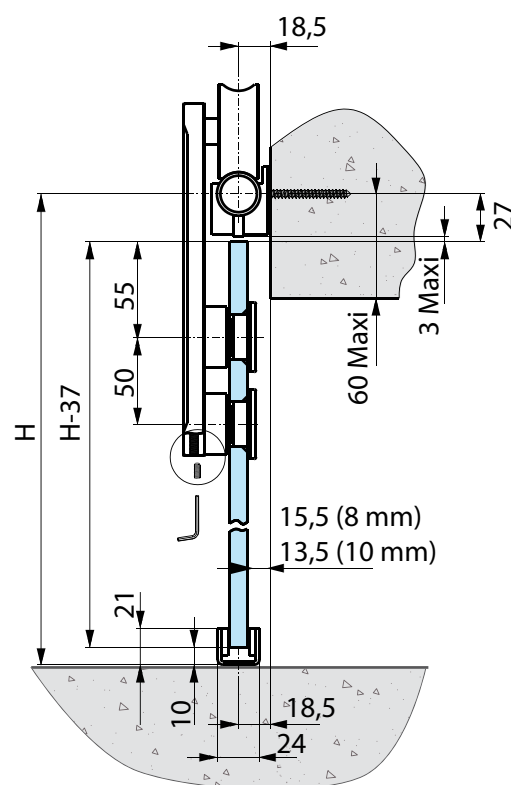
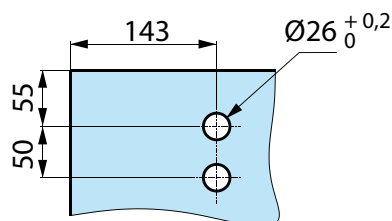



Ce kit comprend

Un rail lg 2000 mm, 5 pièces de fixation murale,
2 chariots, 2 butées Automove, 2 embouts,
1 guide au sol.

This kit includes

*One rail 2000 mm, 5 fittings for wall mounting,
2 glass clamping trolleys with 2 Automoves,
2 end covers, 1 floor guide.*

Systèmes
pour portes
coulissantes
en verre

*Systems for sliding
glass doors*

Slidematic

Caractéristiques techniques générales

- Automatismes pour porte coulissante intérieure pour porte simple ou double
- Opérateur pour porte battante en version tirer ou pousser
- Fonctionnement en tension basse alimentation intégrée
- Pour verre de 10 et 12 mm
- Possibilité de garder la position ouvert ou fermé avec un interrupteur
- Temporisateur réglable
- Usage bureau et résidentiel non intensif

General technical features

- Sliding door operators for interior or exterior applications for single or double doors
- Swing door operators in push or pull version
- Low voltage operating with integrated power supply
- For 10 and 12mm thick glass
- The Door Can Be Kept In Open Position (Or Closed Position) For A Longer Time With A Switch Of External Contact.
- Adjustable Hold Open

SLIDEMATIC1

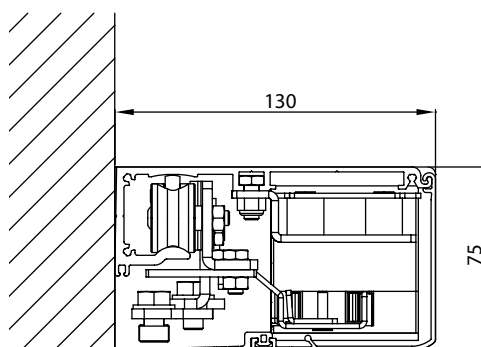

Aluminium anodisé argent brossé
Brushed anodised alu. silver

Références / References

Opérateur complet avec cache et embouts pour porte simple coulissante 'push and go'
Sliding door operator complete with cover and end caps for 'push and go' single door

SLIDEMATIC1.12

- Opérateur longueur 2200 mm recoupable
- Pour porte intérieure largeur maximum 1100 mm, ouverture maxi 1060 mm
- Poids maximum 60 kg
- Prévoir accessoires de fixation de porte SM02
- Opérateur longueur 2200 mm
- For maximum door width 1100 mm, max opening 1060 mm
- Maximum door weight 60 kg
- Fixing accessories for door SM02

SLIDEMATIC2

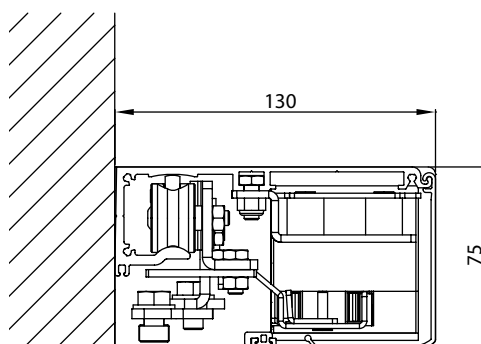

Aluminium anodisé argent brossé
Brushed anodised alu. silver

Références / References

Opérateur complet avec cache et embouts pour portes double coulissantes 'push and go'
Sliding door operator complete with cover and end caps for 'push and go' double doors

SLIDEMATIC2.12

- Opérateur longueur 3300 mm recoupable
- Pour 2 portes intérieures largeur maximum 840 mm, ouverture maxi 1600 mm
- Poids maximum 40 kg par porte
- Prévoir accessoires de fixation de porte SM02
- Opérateur longueur 3300 mm
- For maximum 2 doors width 840 mm, max opening 1600 mm
- Maximum door weight 40 kg per door
- Fixing accessories for door SM02

LES + PRODUITS

The + product

Idéal pour personne
à mobilité réduite

*Ideal for
disabled people*

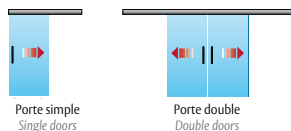

Porte simple
Single doors

Porte double
Double doors

Accessoires Slidematic

Slidematic Accessories

Systemes
pour portes
coulissantes
en verre
Systems for sliding
glass doors

SM02.12

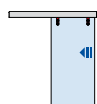
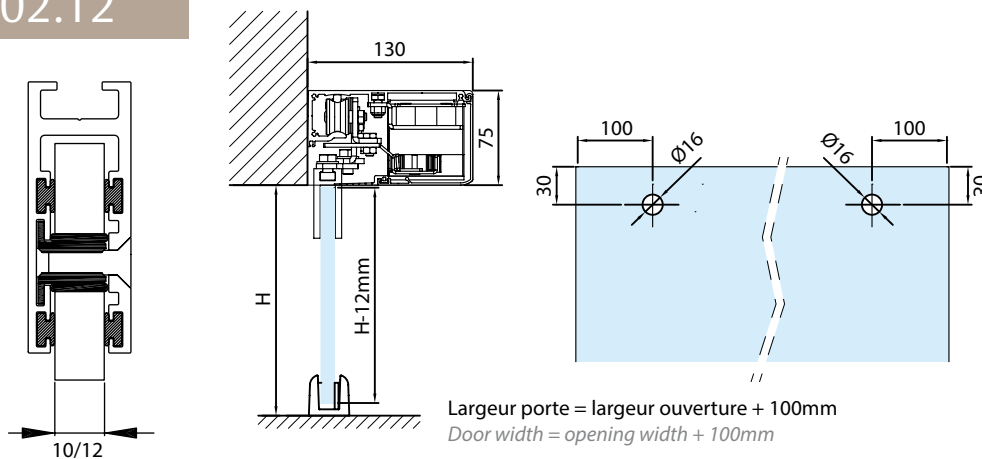

Profil aluminium anodisé argent pour 1 panneau coulissant, longueur 2 m
Aluminium profile for 1 glass panel, 2 m length silver anodised

- Livré avec 1 guide au sol.
• Supplied with 1 floor guide.

SM04.99



Radar 2 directions
Two way sensor

SM07.99

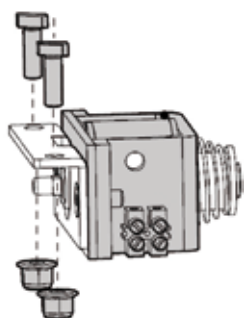

Verrou électro-mécanique pour SLIDEMATIC
Electro-mechanical lock for SLIDEMATIC



Tableau de synthèse

Technical features table

	SLICE 60	SLICE 100	SLICE AUTOMOVE	MAGIC SLIDE	CILINDRIC AUTOMOVE
Technique / Technical					
Poids maxi <i>Max load</i>	60 kg	100 kg	80 kg	80 kg	80 kg
Hauteur maxi <i>Maximum height</i>	3000 mm	3000 mm	3000 mm	2600 mm	2600 mm
Épaisseur verre trempé <i>Toughened glass thickness</i>	8-10 mm	8-10 mm	8-10 mm	8 mm	8-10 mm
Mécanisme invisible <i>Invisibe mechanism</i>				•	
Sans encoche <i>No notch</i>	•	•	•		
Montage au mur <i>Wall installation</i>	•	•	•	•	•
Montage au plafond <i>Ceiling installation</i>	•	•	•		
Montage en galandage <i>Pocket door installation</i>	•	•	•		
Fonction AUTOMOVE <i>AUTOMOVE</i>			•		•
Fonction SYNCHRO <i>SYNCHRO</i>	•				
Dimensions / Sizes					
Hauteur rail <i>Rail height</i>	50	50	50		
Fonctions / Functions					
Porte simple <i>Single door</i>	•	•	•	•	•
Porte double <i>Double door</i>	•	•	•		
Partie fixe en verre <i>Fixed panel</i>	•	•	•		
Finitions / Finishes					
Alu. anodisé argent brossé <i>Brushed anodised alu. silver</i>	•	•	•	•	
Aluminium anodisé aninox <i>Brushed anodised alu.</i>	•	•	•		
Laqué RAL <i>RAL lacquered finish</i>	•	•	•		
Inox brossé <i>Brushed stainless steel</i>					•



Systèmes pour portes repliables
Folding door systems

ASSA ABLOY

Easyfold

EASYFOLD est un système coulissant repliable pour panneaux en verre, prévu aussi bien pour l'intérieur, que pour l'extérieur. Les panneaux sont assemblés en utilisant des charnières combinées avec des guides glissants dans un rail d'aluminium.

Un guide en U ou un seuil avec U de guidage dans le sol est nécessaire.

Les chariots sont équipés de roulements en acier inoxydable, qui couissent doucement et ne nécessitent pas d'entretien.

La paroi peut être sécurisée en utilisant un cale-pied, spécialement étudié.

EASYFOLD, peut être fermé à l'aide d'une serrure avec cylindre prévue sur le dernier panneau.

EASYFOLD is a sliding-and-folding glass panel system for use indoors and out. The panels are assembled using a combination of hinges and rollers sliding inside an aluminium top track.

A simple U-profile or threshold with U-shaped guide is required at floor level.

The trolleys are equipped with smooth sliding stainless steel bearings that are entirely maintenance-free.

The glass panels can be secured using a specially designed spring loaded toe operated clip lock.

EASYFOLD is locked using a cylinder lock fitted to the last panel.



LES + PRODUITS

Transparence totale

Total transparency

Caractéristiques techniques

- Largeur maximale par panneau : 750 mm
- Hauteur maximale par panneau : 2400 mm
- Poids maximal par panneau : 45 kg
- Pour verre trempé épaisseur : 8 ou 10 mm
- 6 panneaux repliables sur un même côté possible

Technical features

- Maximum panel width : 750 mm
- Maximum panel height : 2400 mm
- Maximum panel weight : 45 kg
- For 8 – 10 mm thick toughened glass (not supplied)
- Up to six panels can be assembled on same side

Encombrement des volumes repliés

Size of area for stacked panel

- 2 volumes / 2 panels = 80 mm
- 3 volumes / 3 panels = 120 mm
- 4 volumes / 4 panels = 170 mm
- 5 volumes / 5 panels = 210 mm
- 6 volumes / 6 panels = 250 mm

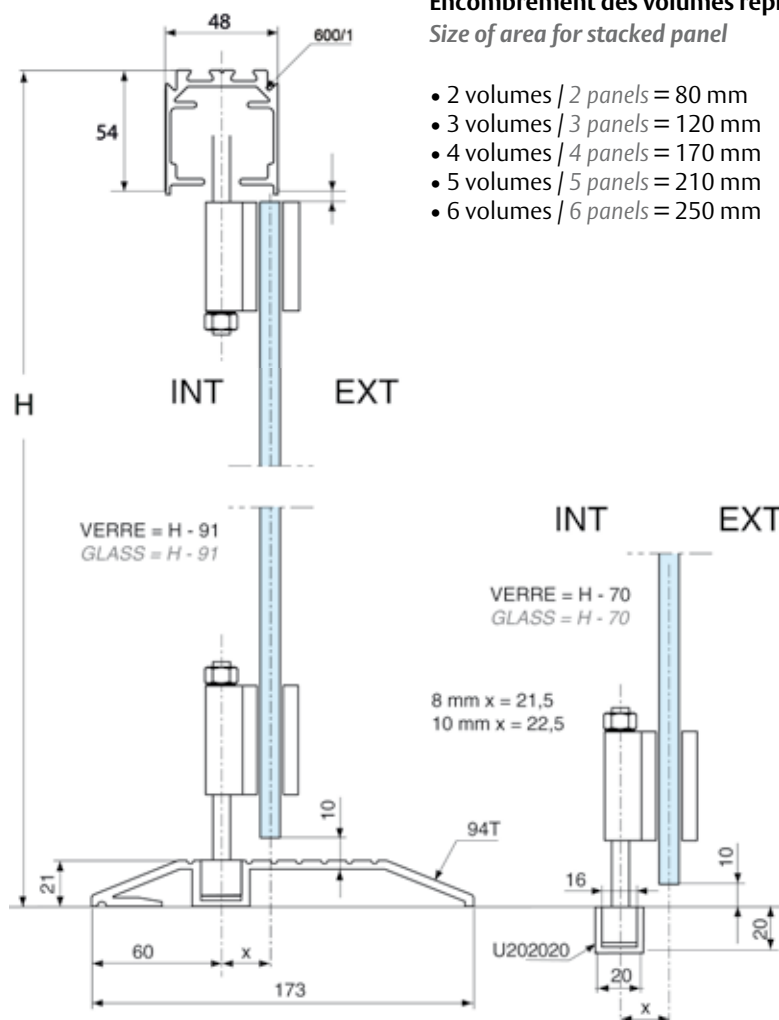

600/1.**

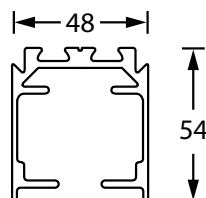

Références / References

EL 6000	EL 3000
------------	------------

Rail pour fixation plafond pour Easyfold
Track profile ceiling mounted for Easyfold



Alu. anodisé argent brossé
Brushed anodised alu. silver



Aluminium anodisé aninox
Brushed anodised alu. aninox

600/1.12

600/1.36

Anodisé argent, rail longueur maxi 6000 mm
Anodisé ANINOX, rail longueur maxi 3000 mm

Brushed Anodized alu silver, maximum track profile length 6000 mm
Brushed anodised alu. , maximum track profile length 3000 mm

94T.**

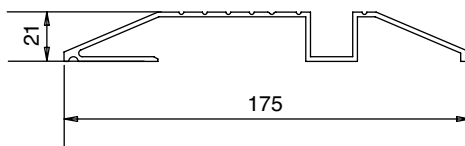

Références / References

EL 6000

Profil 'threshold' hauteur 21 mm
Built-up threshold profile height 21 mm



Alu. anodisé argent brossé
Brushed anodised alu. silver



Aluminium anodisé aninox
Brushed anodised alu. aninox

94T.12

94T.36

Anodisé argent, rail longueur maxi 6000 mm
Anodisé ANINOX, rail longueur maxi 3000 mm

Brushed Anodized alu silver, maximum track profile length 6000 mm
Brushed anodised alu. , maximum track profile length 3000 mm

U202020.**

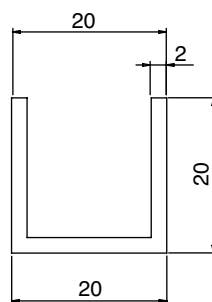

Références / References

EL 6000

Profil U 20x20x20x2 mm
U-profile 20x20x20x2 mm



Alu. anodisé argent brossé
Brushed anodised alu. silver



Aluminium anodisé aninox
Brushed anodised alu. aninox

U202020.12

U202020.36



EF01/V4.**

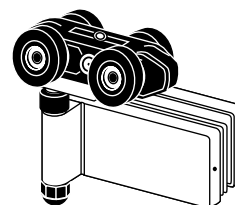

Références / References



Guide offset terminal à 4 roues avec charnière simple
4-wheeled offset end hanger with hinge



Alu. anodisé argent brossé
Brushed anodised alu. silver

Aluminium anodisé aninox
Brushed anodised alu. aninox

EF01/V4.12

EF01/V4.36



EF02.**

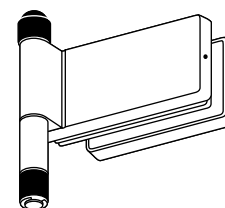

Références / References



Guide inférieur avec charnière simple
End guide with single hinge



Alu. anodisé argent brossé
Brushed anodised alu. silver

Aluminium anodisé aninox
Brushed anodised alu. aninox

EF02.12

EF02.36



EF03.**

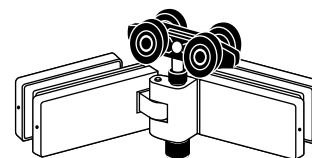

Références / References



Guide central à 4 roues avec charnière double
4-wheeled mid hanger with double hinge



Alu. anodisé argent brossé
Brushed anodised alu. silver

Aluminium anodisé aninox
Brushed anodised alu. aninox

EF03.12

EF03.36

EF04.**

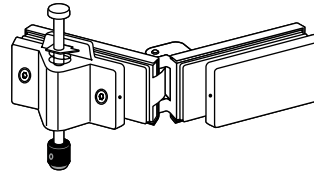

Systemes pour
portes repliables
Folding door
systems

Références / References



Charnière double avec cale-pied
(serrure seulement disponible en gris et noir laqué)
Double hinge with spring-loaded, foot-operated bolt
(lock only available in lacquered finish grey or black)



Alu. anodisé argent brossé
Brushed anodised alu. silver



Aluminium anodisé aninox
Brushed anodised alu. aninox

EF04.12

EF04.36

EF06.**

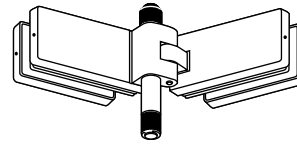

Références / References



Guide inférieur avec charnière double
Mid guide with double hinge



Alu. anodisé argent brossé
Brushed anodised alu. silver



Aluminium anodisé aninox
Brushed anodised alu. aninox

EF06.12

EF06.36

EF07.**

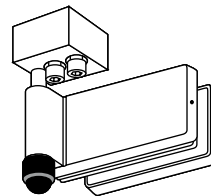

Références / References



Pivot supérieur avec charnière
Top pivot with hinge



Alu. anodisé argent brossé
Brushed anodised alu. silver



Aluminium anodisé aninox
Brushed anodised alu. aninox

EF07.12

EF07.36

EF08.**

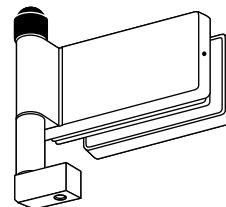

Références / References



Pivot inférieur avec charnière
Bottom pivot with hinge



Alu. anodisé argent brossé
Brushed anodised alu. silver

Aluminium anodisé aninox
Brushed anodised alu. aninox

EF08.12

EF08.36



EF09.**

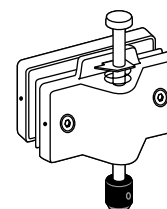

Références / References

Cale-pied pour verre
(disponible en gris et noir laqué)
Spring-loaded, foot-operated lock
(available in lacquered finish grey or black)



Alu. anodisé argent brossé
Brushed anodised alu. silver

Aluminium anodisé aninox
Brushed anodised alu. aninox

EF09.12

EF09.36

V507

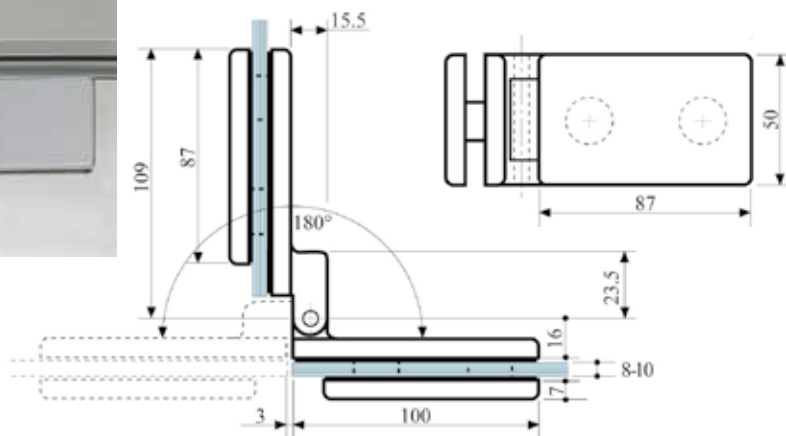

Références / References



Paumelle double verre/verre pour portes simple action
Glass to glass hinge for single action doors

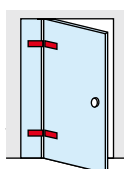

Laiton poli verni
Polished varnished brass

Alu. anodisé argent brossé
Brushed anodised alu. silver

Chromé brillant
Bright chromium

Chromé mat brossé
Brushed matt chromium

Aluminium anodisé Aninox
Brushed anodised alu. aninox

V507.01

V507.12

V507.30.0

V507.33

V507.36

van

Systèmes pour
portes repliables
*Folding door
systems*



Easyfold

2 volumes - 2 panels

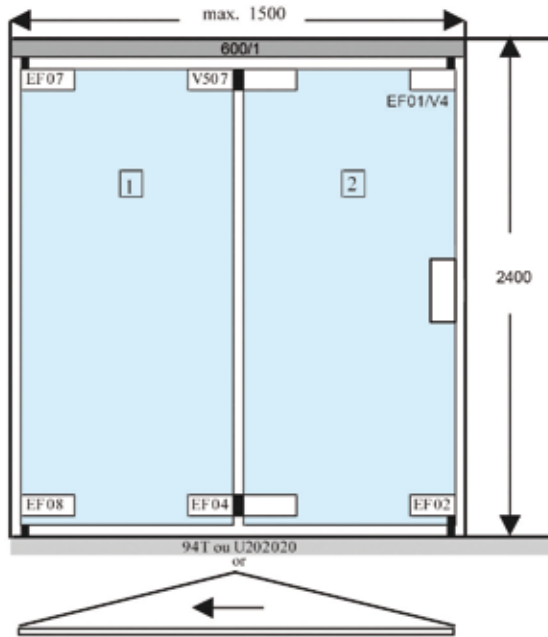

Accessoires nécessaires / References needed :

600/1 L = Largeur de l'ouverture en mm
L = Width of the opening in mm

94T ou/or U202020 L = Largeur de l'ouverture en mm
L = Width of the opening in mm

EF07	Q = 1
EF08	Q = 1
V507	Q = 1
EF04	Q = 1
EF01/V4	Q = 1
EF02	Q = 1

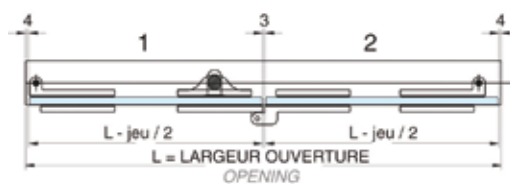
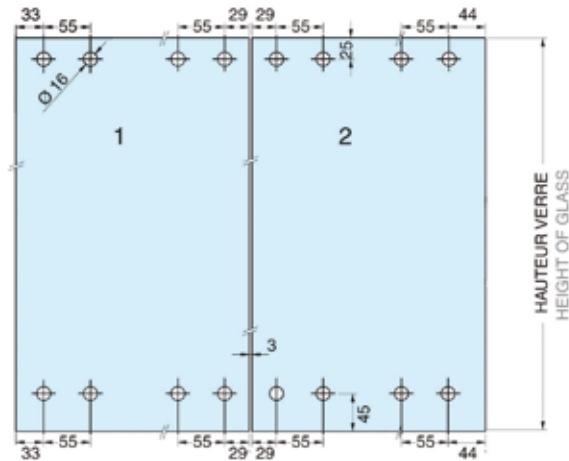

Hauteur verre = Hauteur de l'ouverture - 70 mm avec le U202020
= En cas de threshold - 91 mm avec le 94T

Panel height = Opening height - 70 mm with the U202020 profile
= If using threshold profile - 91 mm with the 94T profile

Information sur le calcul de la hauteur des volumes en début de chapitre.

Information on the calculation of the height of the glass panels at the beginning of the chapter

Easyfold

3 volumes - 3 panels

Systèmes pour
portes repliables
Folding door
systems

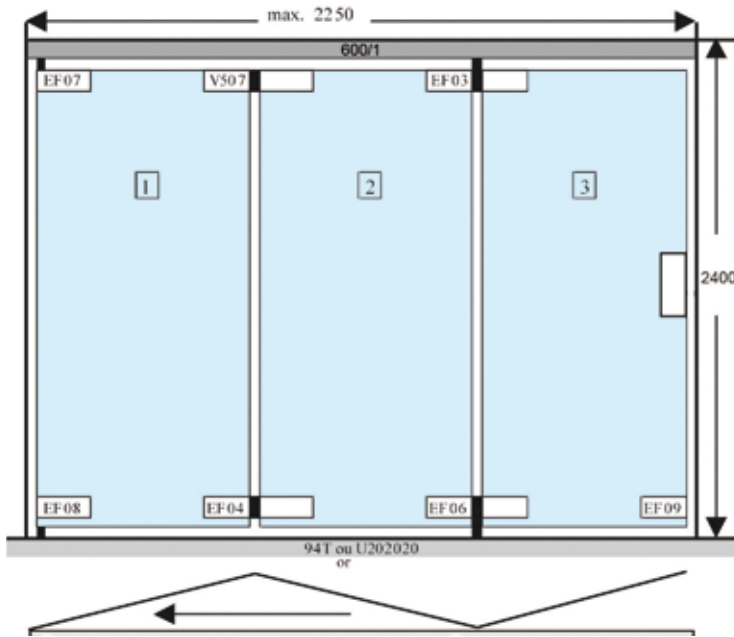

Accessoires nécessaires / References needed :

600/1 L = Largeur de l'ouverture en mm
L = Width of the opening in mm

94T ou/or
U202020 L = Largeur de l'ouverture en mm
L = Width of the opening in mm

EF07	Q = 1
EF08	Q = 1
V507	Q = 1
EF04	Q = 1
EF03	Q = 1
EF06	Q = 1
EF09	Q = 1

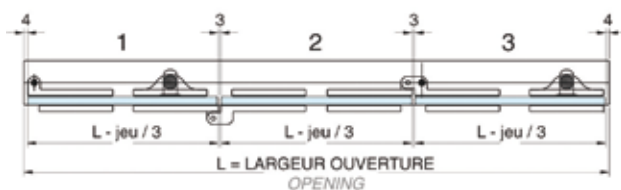
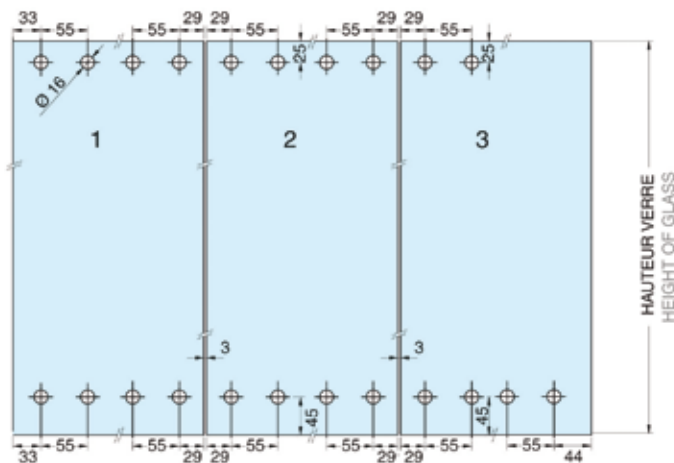

Hauteur verre = Hauteur de l'ouverture - 70 mm avec le U202020
= En cas de threshold - 91 mm avec le 94T

Panel height = Opening height - 70 mm with the U202020 profile
= If using threshold profile - 91 mm with the 94T profile

Information sur le calcul de la hauteur des volumes en début de chapitre.

Information on the calculation of the height of the glass panels at the beginning of the chapter

Easyfold

4 volumes - 4 panels

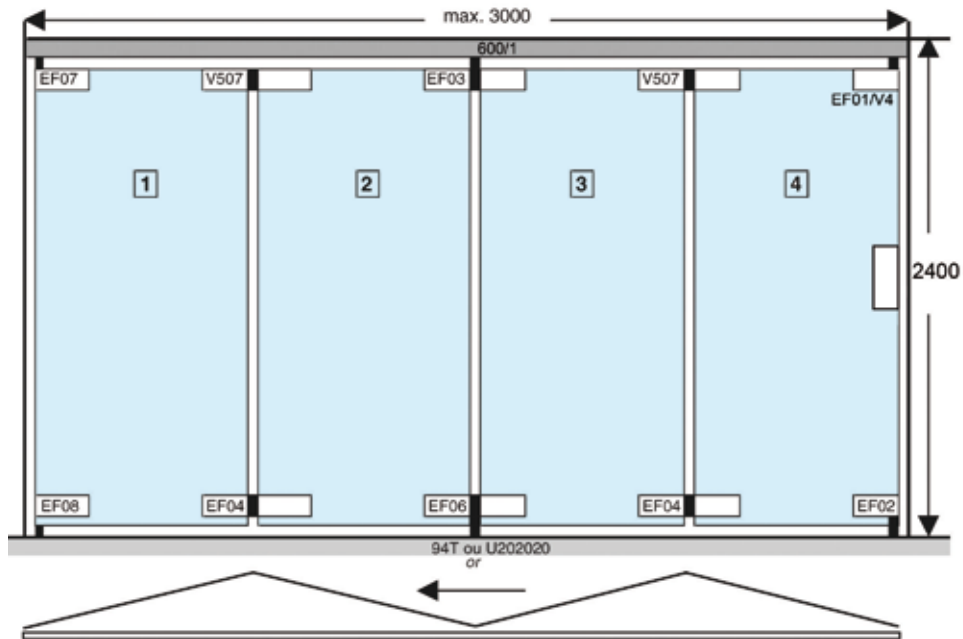

Accessoires nécessaires / References needed :

600/1 L = Largeur de l'ouverture en mm
L = Width of the opening in mm

94T ou/or U202020 L = Largeur de l'ouverture en mm
L = Width of the opening in mm

EF07 Q = 1

EF08 Q = 1

V507 Q = 2

EF04 Q = 2

EF03 Q = 1

EF01/V4 Q = 1

EF06 Q = 1

EF02 Q = 1

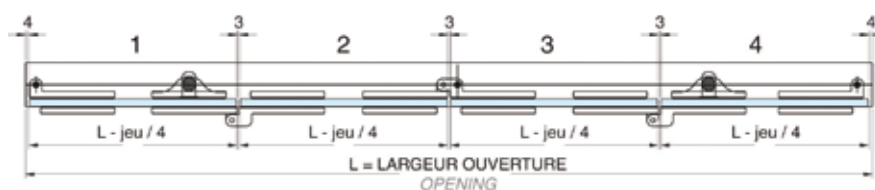
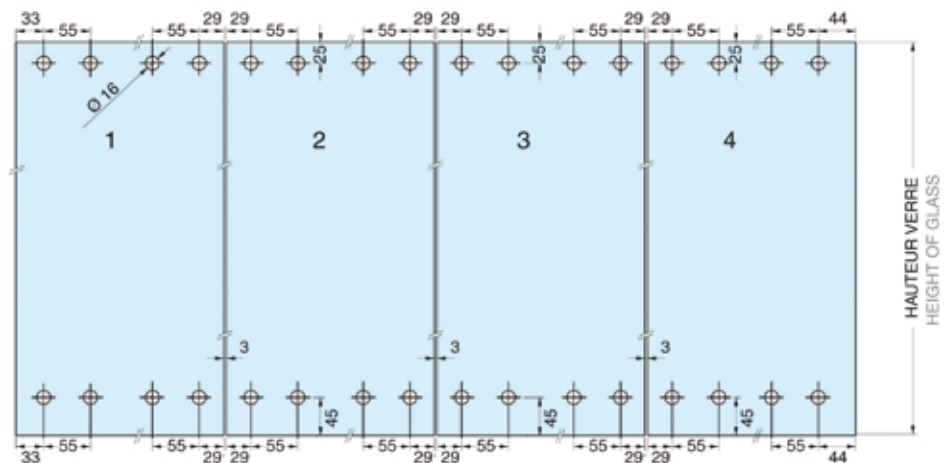

Hauteur verre = Hauteur de l'ouverture - 70 mm avec le U202020
= En cas de threshold - 91 mm avec le 94T

Panel height = Opening height - 70 mm with the U202020 profile
= If using threshold profile - 91 mm with the 94T profile

Information sur le calcul de la hauteur des volumes en début de chapitre.

Information on the calculation of the height of the glass panels at the beginning of the chapter

Easyfold

5 volumes - 5 panels

Systèmes pour portes repliables
Folding door systems

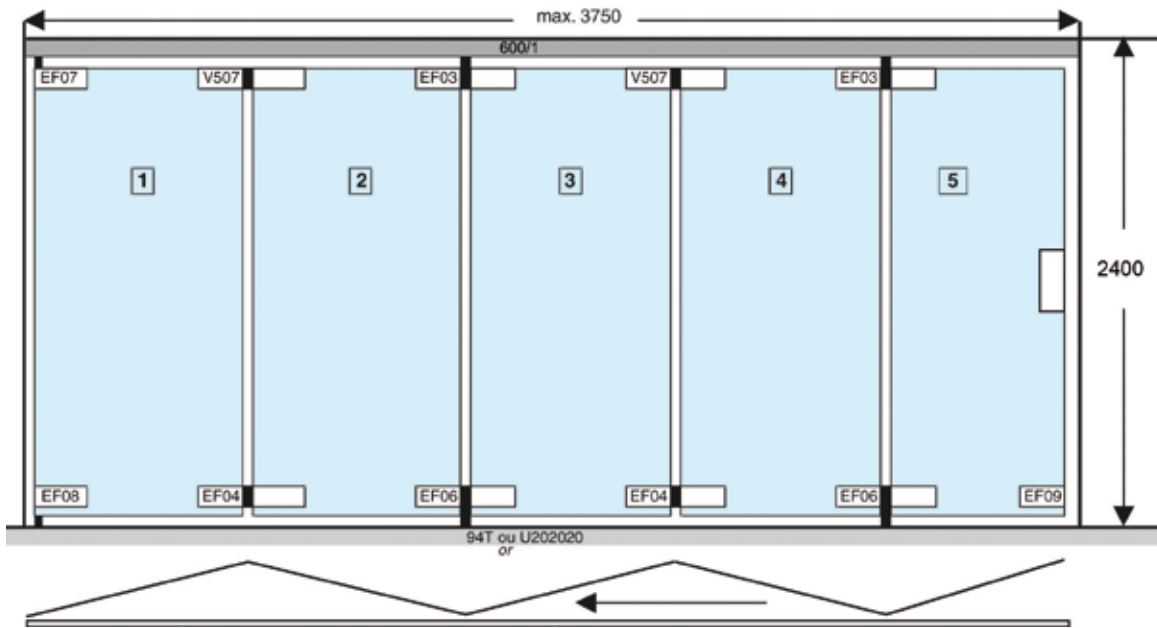

Accessoires nécessaires / References needed :

600/1	L = Largeur de l'ouverture en mm L = Width of the opening in mm
94T ou/or U202020	L = Largeur de l'ouverture en mm L = Width of the opening in mm

EF07	Q = 1
EF08	Q = 1
V507	Q = 2
EF04	Q = 2
EF03	Q = 2
EF06	Q = 2
EF09	Q = 1

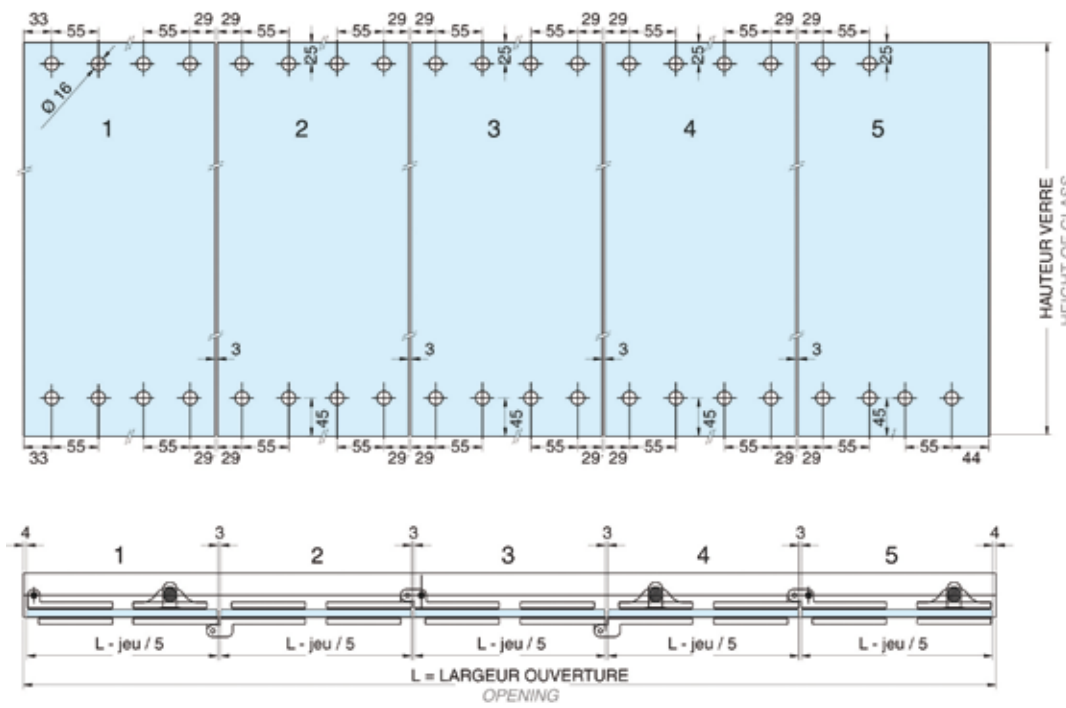

Hauteur verre	= Hauteur de l'ouverture - 70 mm avec le U202020 = En cas de threshold - 91 mm avec le 94T
Panel height	= Opening height - 70 mm with the U202020 profile = If using threshold profile - 91 mm with the 94T profile

Information sur le calcul de la hauteur des volumes en début de chapitre.
Information on the calculation of the height of the glass panels at the beginning of the chapter

Easyfold

6 volumes - 6 panels

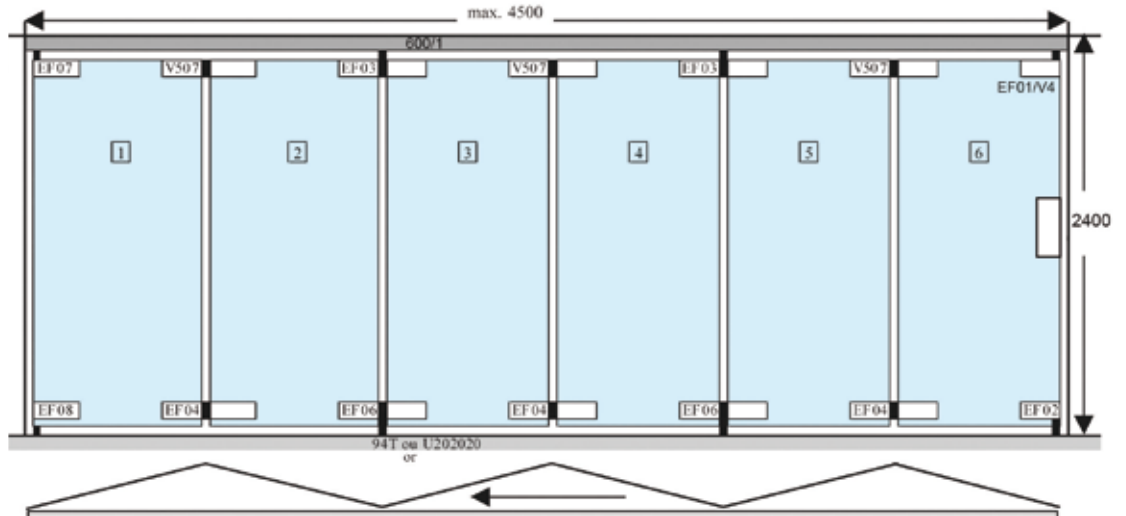

Accessoires nécessaires / References needed :

600/1 L = Largeur de l'ouverture en mm
L = Width of the opening in mm

94T ou/or U202020 L = Largeur de l'ouverture en mm
L = Width of the opening in mm

EF07 Q = 1

EF08 Q = 1

V507 Q = 3

EF04 Q = 3

EF03 Q = 2

EF06 Q = 2

EF01/V4 Q = 1

EF02 Q = 1

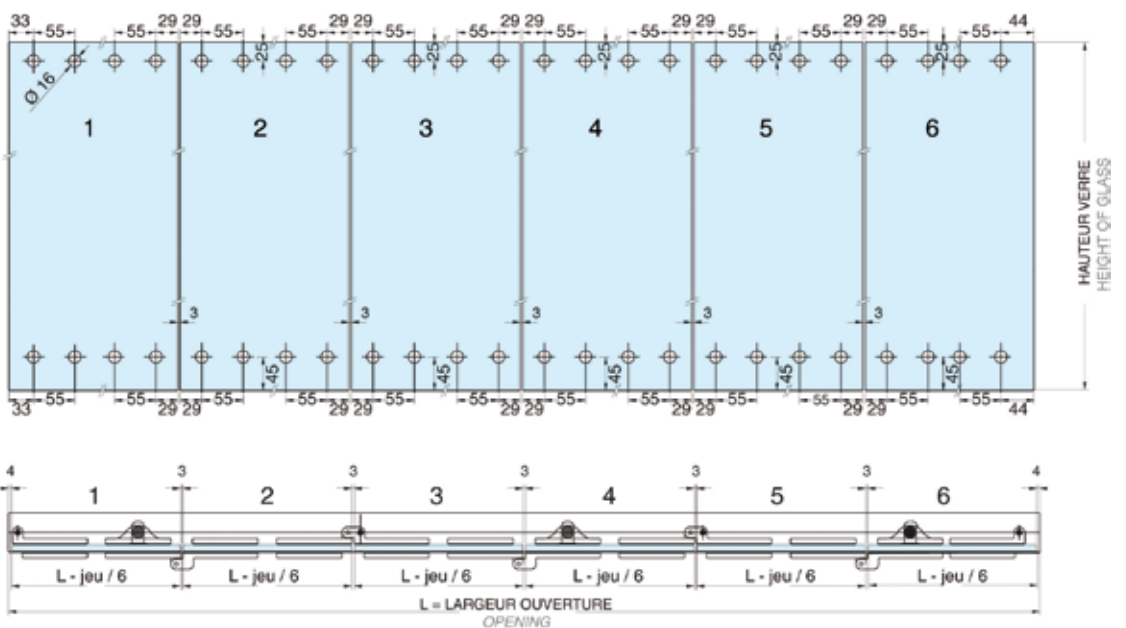

Hauteur verre = Hauteur de l'ouverture - 70 mm avec le U202020
= En cas de threshold - 91 mm avec le 94T

Panel height = Opening height - 70 mm with the U202020 profile
= If using threshold profile - 91 mm with the 94T profile

Information sur le calcul de la hauteur des volumes en début de chapitre.

Information on the calculation of the height of the glass panels at the beginning of the chapter

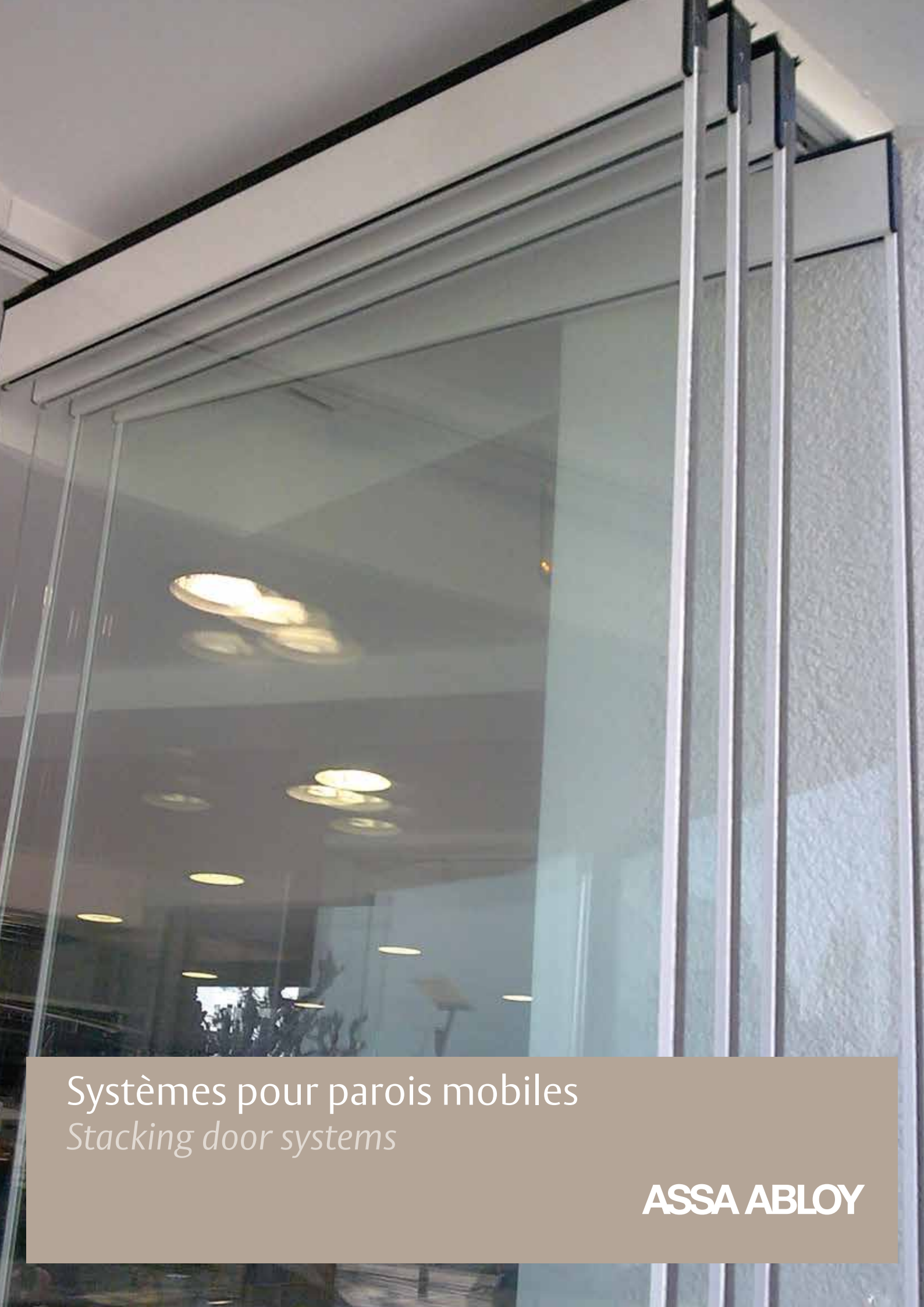

Systèmes pour parois mobiles
Stacking door systems

ASSA ABLOY

Flexystack 250



Le système FLEXYSTACK 250 consiste en une paroi mobile comportant des panneaux suspendus.

Le système convient aussi bien pour des parois intérieures que pour des parois extérieures.

Les panneaux sont maniés individuellement et manuellement pour être installés dans leur position de rangement et ouvrir la totalité de la baie.

Le rangement peut être réalisé de façon à ce que les panneaux restent hors de vue ou même rangés dans un emplacement à part, sans gêner l'ouverture.

FLEXYSTACK 250 est une paroi mobile, jusqu'à 250 kg par panneau, le rail a un design esthétique et le corps des rouleaux est en acier inoxydable avec une bande de roulement qui réduit le bruit.

The FLEXYSTACK 250 system consists of a mobile partition comprising suspended panels.

Without floor guide, the system is suitable for both internal and external partitions. Each panel is placed manually into its storage position so that the entire bay can be opened up.

The panels can be stored in such a way that they are out of sight or even stored in a separate location, without obstructing the entrance.

FLEXYSTACK 250 is a stacking door system, up to 250 kgs per panel, the track profile has an aesthetic design, the wheels of the stainless steel hangers are covered with a noise reducing material.

LES + PRODUITS

Grandes ouvertures

Modulable

Pas de guidage au sol

Large opening

Modularity

No floor guide



Alu. anodisé argent brossé
Brushed anodised alu. silver



Aluminium anodisé aninox
Brushed anodised alu. aninox



Laqué RAL
Lacquered RAL

Caractéristiques techniques

FLEXYSTACK 250

- Poids maximum 250 kg par panneau
- Hauteur maximum 3000 mm
- Pour l'épaisseur en verre 10 mm et 12 mm, aucune préparation en verre requise

Technical features

FLEXYSTACK 250

- Maximum weight 250 kg per panel
- Maximum door height 3000 mm
- For glass thickness 10 mm and 12 mm, no glass preparation required





Chariot / Trolley



Aiguillage / Panel di-
verter

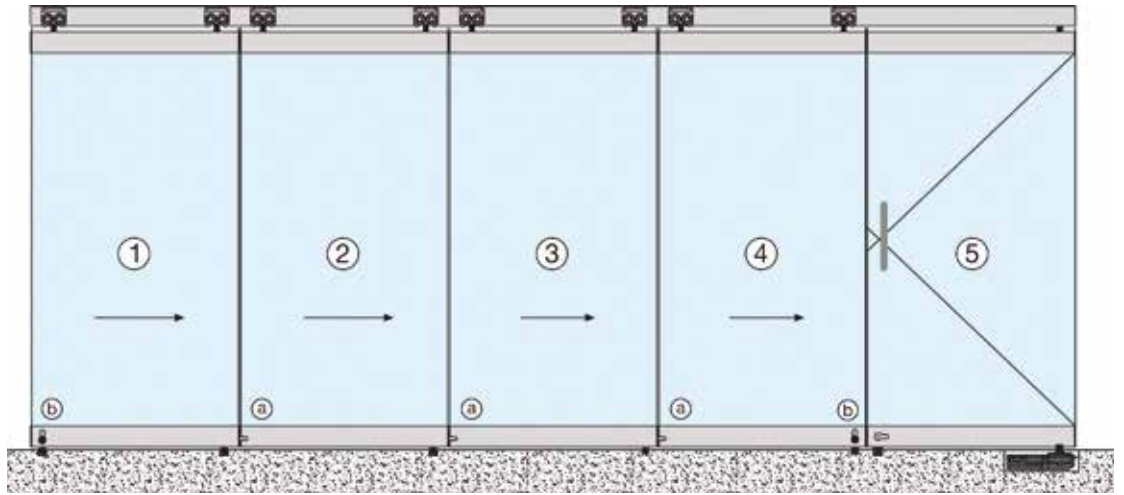

Fermetures : différentes possibilités
Locking : different possibilities

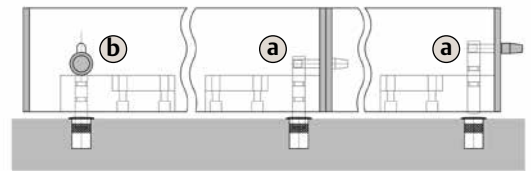

Le rangement à 90°
The 90° degree stacking arrangement

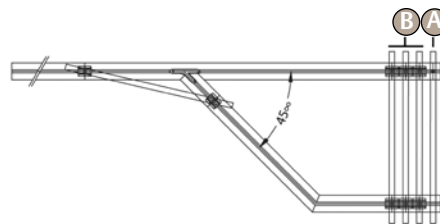

Les panneaux sont rangés avec un angle droit
au regard du rail principal.
Panels are stacked at a right angle with the main profile.

- Ⓐ Porte va-et-vient fixe sur pivot de sol ou pivot libre.
Fixed swing door on floor closer or on a free swing pivot.
- Ⓑ Panneaux coulissants
Sliding panels.

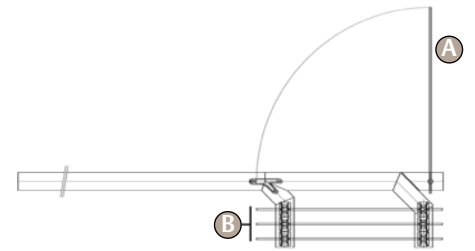

Les panneaux sont rangés parallèles au regard
du rail principal.
Panels are stacked parallel with the main profile.

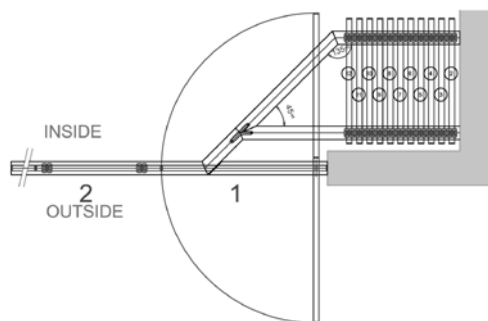

Panneaux rangés derrière un mur. Le premier panneau
est une porte fixe sur frein ou pivot libre.
Panels are stacked behind a wall. First panel is a swing door.

Pour chaque situation spécifique nous offrons une solution !
A solution for all situations !



Coupe du profilé (panneau coulissant) FLEXYSTACK 250
Cross section (sliding panel) FLEXYSTACK 250

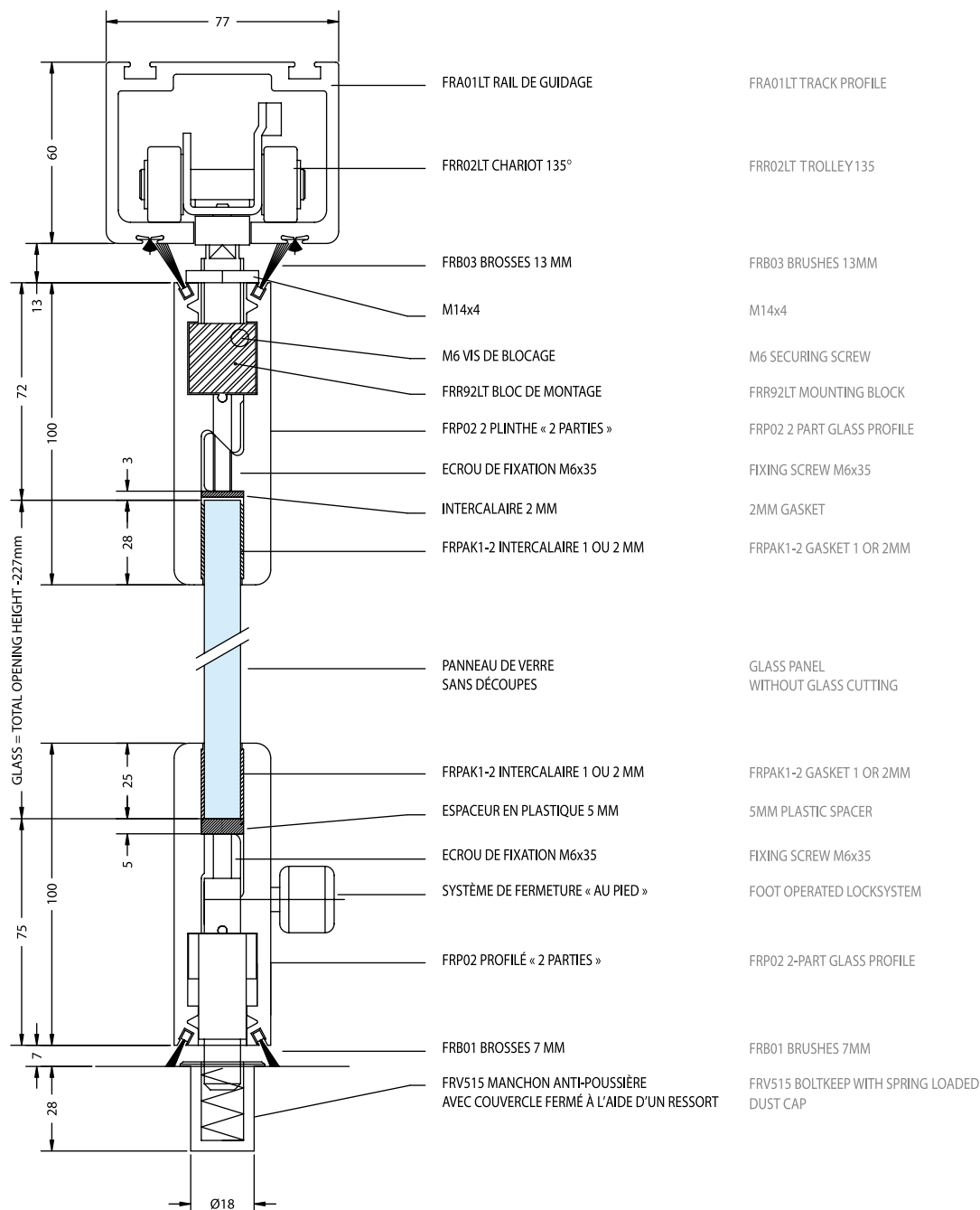

Accessoires

Accessories

Références / References



Anneau de tirage
Ring pull



Chromé brillant
Bright chromium



Chromé mat
Matt chromium

SL27.30

SL27.31



Poignée 'G' pour porte coulissante
'G' shaped handle for sliding doors



Inox brossé
Brushed stainless steel

AMGMODEL/8.15



Poignée 'G' pour porte coulissante
'G' shaped handle for sliding doors

AMGMODEL/10.15



Serrure verticale à crochet avec poignées + gâche plate et cylindre
Vertical hook-lock with handles + flat keep and cylinder



Chromé brillant
Bright chromium



Chromé mat
Matt chromium



Effet Inox
Stainless steel effect

SL93.30

SL93.31

SL93.35

Serrure verticale à crochet sans poignée + gâche plate et cylindre
Vertical hook-lock without handle + flat keep and cylinder

SL94.30

SL94.31

SL94.35

Contre boîtier sans poignée pour serrure SL94
Patch keep without handle for lock SL94

SL95.30

SL95.31

SL95.35

Contre boîtier avec poignées pour serrure SL93
Patch keep with handle for lock SL93

SL96.30

SL96.31

SL96.35

SL27.**

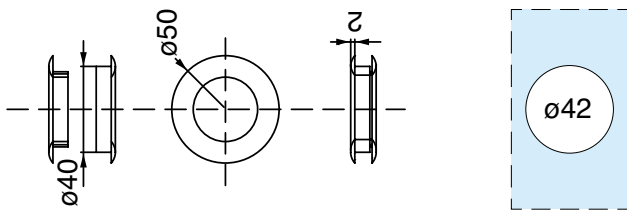

AMGMODEL/.****

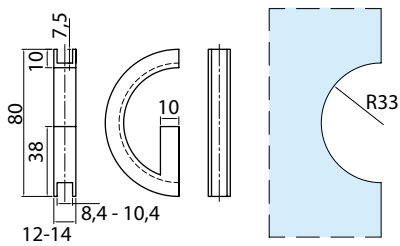

SL93

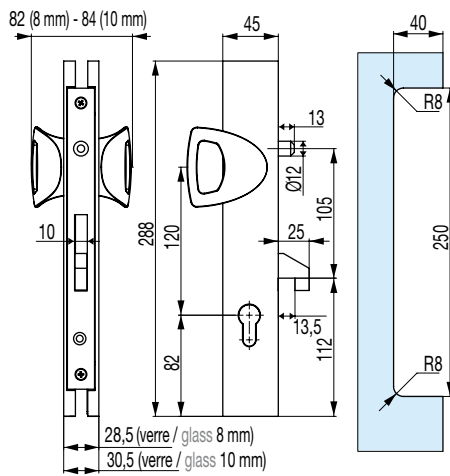

SL94

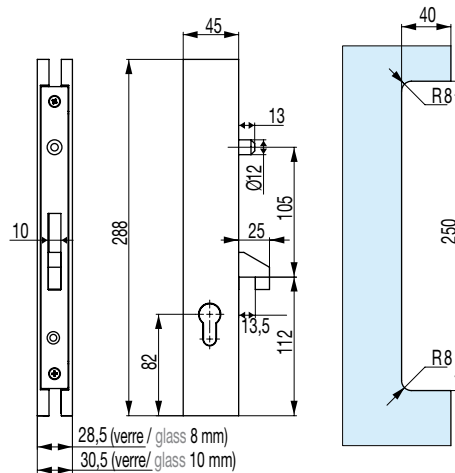

SL96

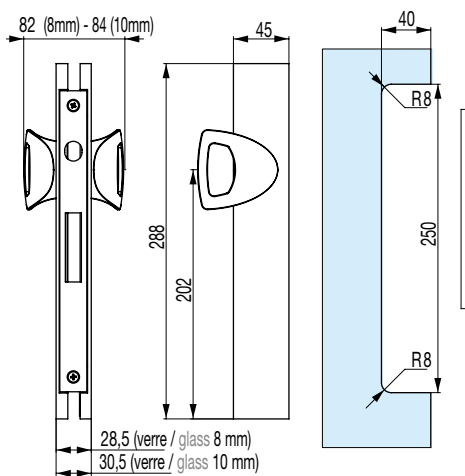

SL95

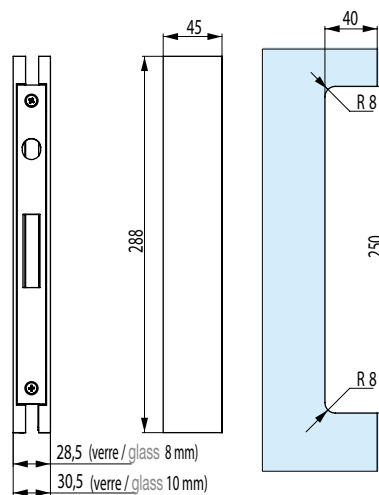





Serrures et paumelles
Locksets and hinges

ASSA ABLOY

Accessoires pour porte en verre

Glass door accessories

Plinthe automatique

Drop-down seal

2815L833.*

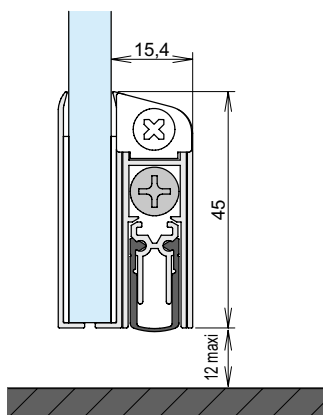

LES + PRODUITS
The + product

Design

Nombreuses
versions

Réversible

Elegant Design

Large variety
of models

Reversible

- Optimise l'isolation acoustique et thermique de la porte
- Pas d'encoche
- Installation possible sur porte existante ou neuve
- Testé pour plus de 1 000 000 de cycles

- Optimize the soundproofing and thermal insulation
- No notches
- Possible installation on existing or new doors
- Tested for more than 1,000,000 cycles

Références / References



Aluminium anodisé Argent Brossé
Brushed anodised alu. silver

Aluminium anodisé Aninox
Brushed anodised alu. aninox

Joint bas de porte automatique avec cache adhésif Lg 708-833 mm
Drop down seal self adhesive with cover L 708-833 mm

2815L833.12

2815L833.36

Joint bas de porte automatique avec cache adhésif Lg 833-958 mm
Drop down seal self adhesive with cover L 833-958 mm

2815L958.12

2815L958.36

Joint bas de porte automatique avec cache adhésif Lg 953-1083 mm
Drop down seal self adhesive with cover L 953-1083 mm

2815L1083.12

2815L1083.36

Joint bas de porte automatique avec cache adhésif Lg 1083-1208 mm
Drop down seal self adhesive with cover L 1083-1208 mm

2815L1208.12

2815L1208.36

Ferme-porte pour porte en verre

Door closer for glass door

Serrures et
paumelles
Locksets and
hinges

Caractéristiques techniques

- Technologie à came
- Force réglable 1-4 EN
- Vitesse de fermeture, et à-coup final réglable
- Système de blocage intégré réglable
- Marque CE

Technical features

- Cam Motion technology
- Adjustable force EN 1-4
- Adjustable closing speed, latching speed and back check
- Integrated hold open device adjustable to the desired angle
- CE Marked

DC500.73

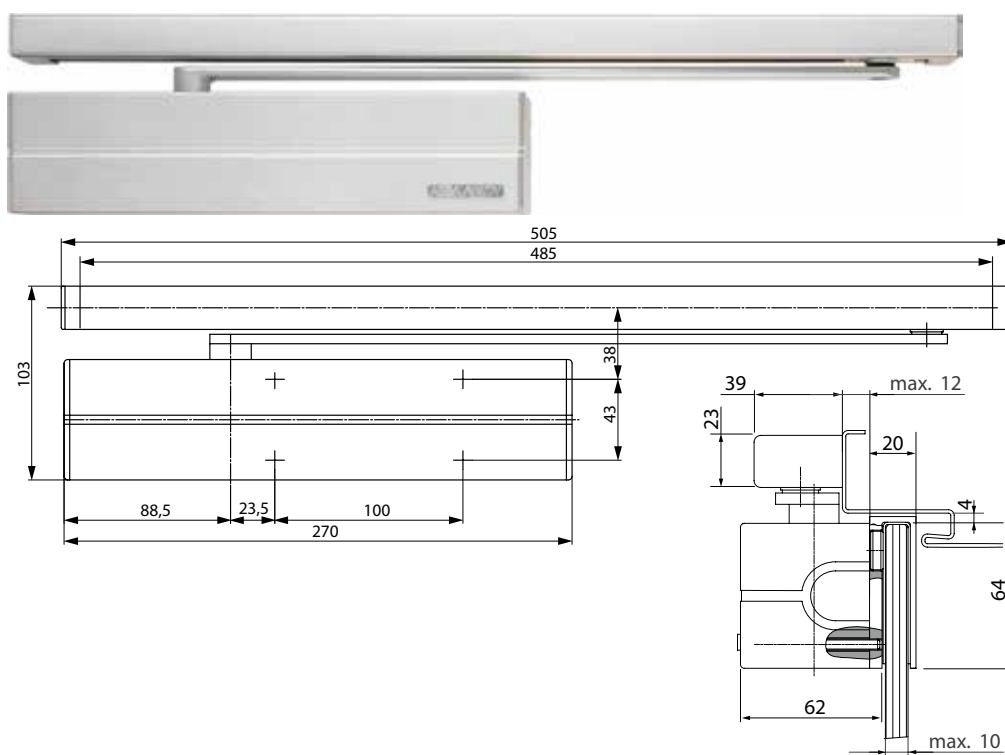

Laqué argent
Lacquered silver

Ferme-porte avec arrêt réglable et cavalier.
Door closer with hold open for tempered glass doors

DC500.73

Cale de compensation 25 mm pour ferme porte DC500
Shims 25 mm thick for door closer DC500

AC500.25.73

2881.15.0



Inox Brossé
Brushed stainless steel

Références / References

Butée de porte Ø 35 mm hauteur 40 mm
Door stop 35 Ø X 40 mm height

2881.15.0

Serrures *Locksets*

Lagune

Caractéristiques techniques générales

- Montage sur encoche 64A
- Réversible
- À cylindre européen panneton DIN (norme DIN 18254)
- Rappel du pêne à la clé
- Pour porte en verre trempé de 8 et 10 mm
- Condamnation par clé avec avancement du pêne
- Possibilités de combinaison avec passe général
- Livrée avec gâche plate et 3 clés

General technical features

- To fit notch 64A
- Reversible
- European profile cylinder (DIN standard 18254)
- Return of latch bolt by key
- For toughened glass doors 8-10 mm thick
- Locked by key with forward motion of latch bolt
- Possibility of combinations with master key
- Supplied with flat keep and 3 keys

4300

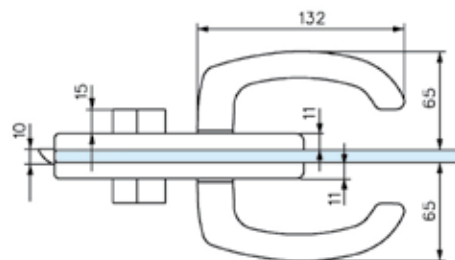
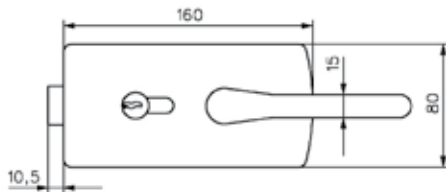
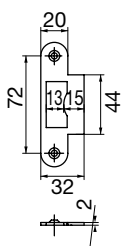
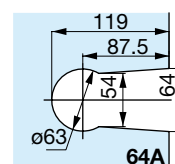

Références / References

Serrure de milieu à cylindre et double béquilles
Lock with euro profile cylinder and pair of handles



Chromé brillant
Bright chromium



Chromé mat
Matt chromium



Doré
Gold plated



Laqué blanc 9010
Lacquered white RAL 9010

4300.30.0

4300.31.0

4300.40.0

4300.51.0



4309.**.0

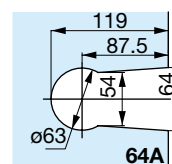

Références / References

Boîtier gâche serrures séries 4300
Matching patch keep for locks series 4300-4310-4350



Chromé brillant
Bright chromium



Chromé mat
Matt chromium



Doré
Gold plated



Laqué blanc 9010
Lacquered white RAL 9010

4309.30.0

4309.31.0

4309.40.0

4309.51.0





Chromé brillant
Bright chromium



Chromé mat
Matt chromium

0309

Gâche équerre pour serrures séries 4300-4310
Keep plate with stop for locks series 4300-4310

0309.30.0

0309.31.0

4306

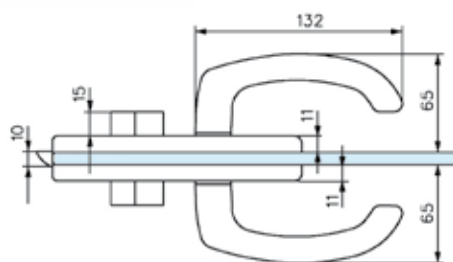
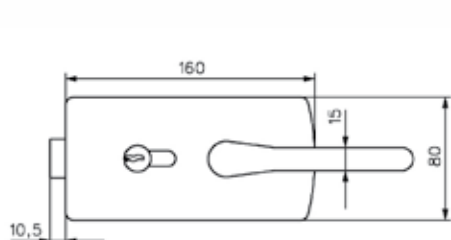
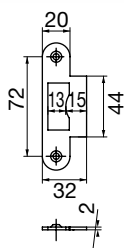
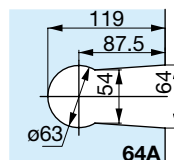

Références / References



Chromé brillant
Bright chromium



Chromé mat
Matt chromium

Serrure de milieu à cylindre et béquilles condamnation
sans avancement du pêne

Lock with euro profile cylinder and double handles, without
forward motion of latch bolt

4306.30.0

4306.31.0

4301

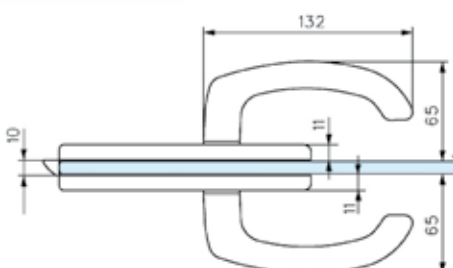
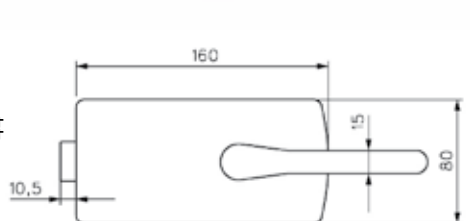
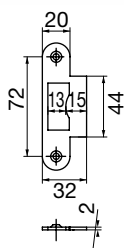
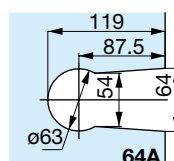

Références / References



Chromé brillant
Bright chromium



Chromé mat
Matt chromium



Doré
Gold plated



Laqué blanc 9010
Lacquered white RAL 9010

Serrure de milieu bec de canne
et double béquilles

Latch set with pair of handles

4301.30.0

4301.31.0

4301.40.0

4301.51.0

4307

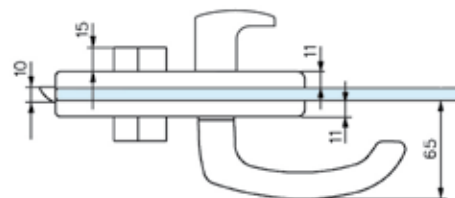
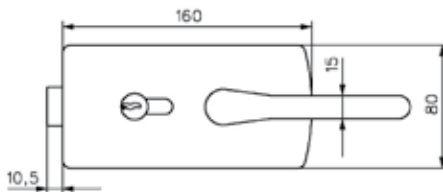
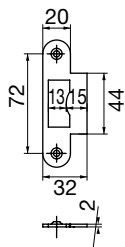
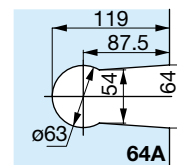

Références / References



Chromé brillant
Bright chromium



Chromé mat
Matt chromium

Serrure de milieu à cylindre avec béquille intérieure et bouton fixe extérieur, condamnation sans avancement du pêne

Lock with euro profile cylinder, lever handle inside and fixed knob outside, without forward motion of latch bolt

4307.30.0

4307.31.0

4310

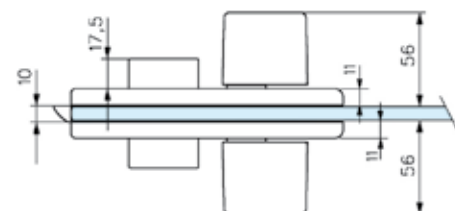
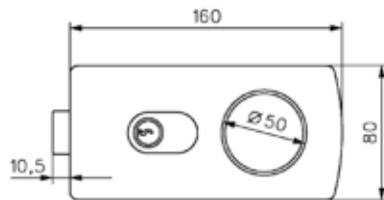
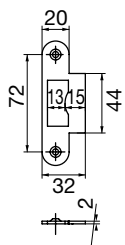
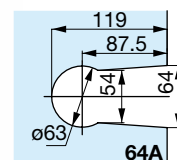

Références / References



Chromé brillant
Bright chromium



Chromé mat
Matt chromium

Serrure de milieu à cylindre et boutons de manoeuvre avec caches cylindre

Lock with euro profile cylinder and pair of knobs with cylinder covers

4310.30.0

4310.31.0

4311

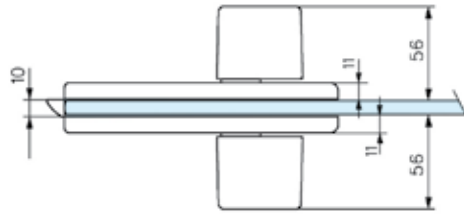
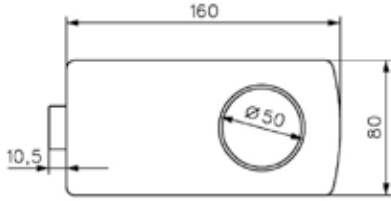
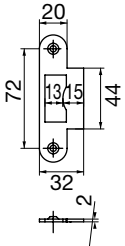
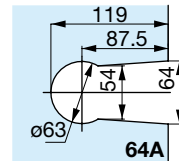

Références / References



Chromé brillant
Bright chromium



Chromé mat
Matt chromium

Serrure de milieu bec de cane et boutons de manoeuvre
Latch lock with pair of knobs

4311.30.0

4311.31.0

4312

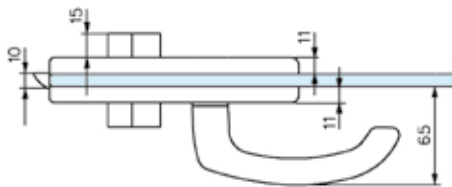
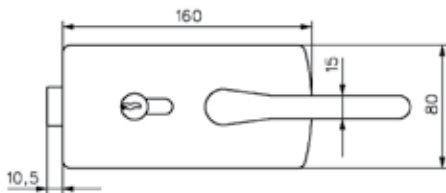
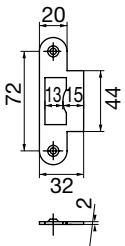
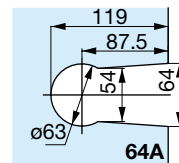

Références / References



Chromé brillant
Bright chromium



Chromé mat
Matt chromium

Serrure de milieu à cylindre avec une seule béquille intérieure
Lock with euro profile cylinder and lever handle inside only

4312.30.0

4312.31.0

4360

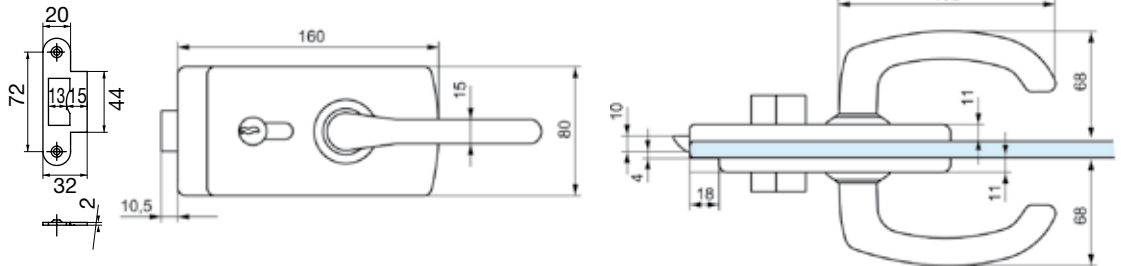
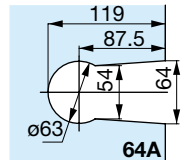

Références / References

Serrure de milieu à cylindre et béquilles avec déport, pêne axé
Lock with euro profile cylinder, handles and offset mechanism



4360.30.0

4360.31.0

4360.40.0

4360.51.0



4360.30.4

4360.31.4

• Le mécanisme déporté permet un contact de la porte en fond de feuillure, et assure la continuité du joint au niveau de la serrure.

• *Offset mechanism to allow compression of rebate strip.*

4361

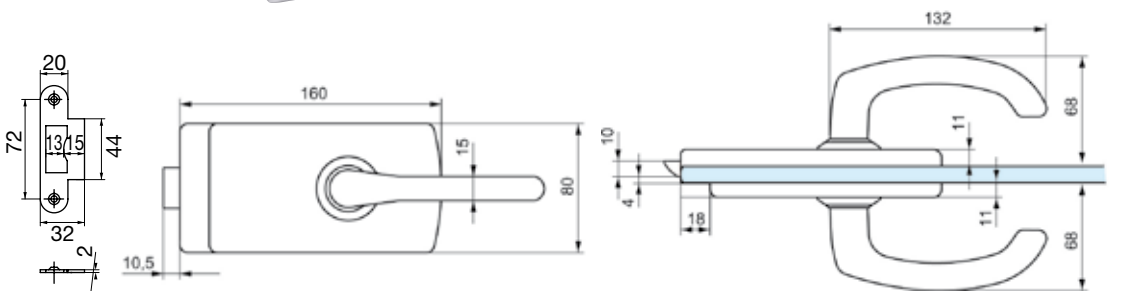
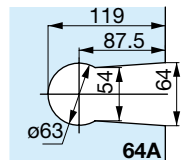

Références / References

Serrure de milieu bec de cane et béquilles avec déport, pêne axé
Latch set with handles and offset mechanism



4361.30.0

4361.31.0

4361.40.0

4361.51.0



4361.30.4

4361.31.4

• Le mécanisme déporté permet un contact de la porte en fond de feuillure, et assure la continuité du joint au niveau de la serrure.

• *Offset mechanism to allow compression of rebate strip.*

LES + PRODUITS

Mécanisme déporté

Offset mechanism



4360.0BT

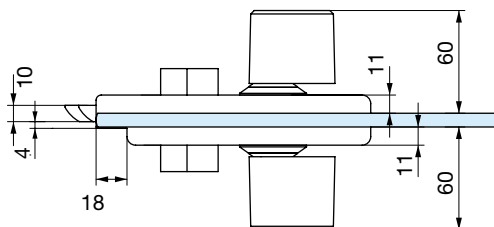
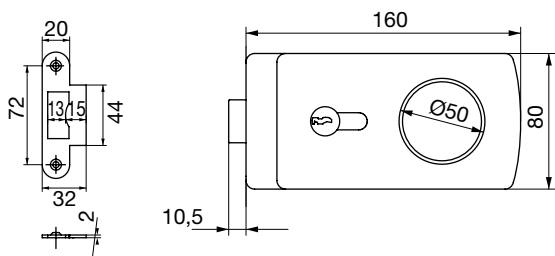
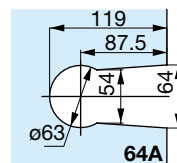

Références / References



Chromé brillant
Bright chromium



Chromé mat
Matt chromium



Laqué blanc 9010
Lacquered white RAL 9010

Serrure de milieu à cylindre et boutons de manoeuvre avec déport, pêne axé
Lock with euro profile cylinder with pair of knobs and offset mechanism

4360.30.0BT

4360.31.0BT

4360.51.0BT

- Le mécanisme déporté permet un contact de la porte en fond de feuillure, et assure la continuité du joint au niveau de la serrure.

- Offset mechanism to allow compression of rebate strip.

4361.0BT

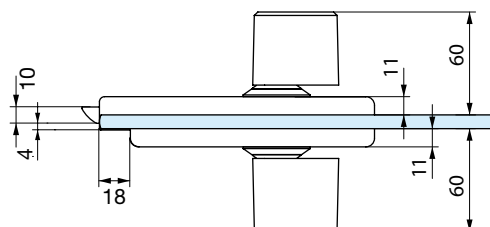
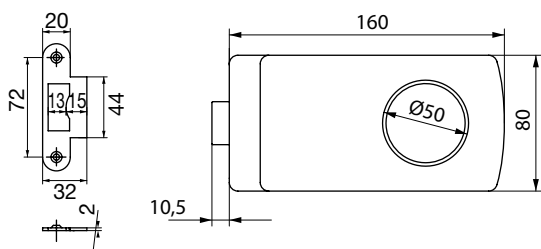
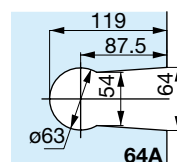

Références / References



Chromé brillant
Bright chromium



Chromé mat
Matt chromium



Laqué blanc 9010
Lacquered white RAL 9010

Serrure de milieu bec de cane avec déport et 2 boutons de manoeuvre
Latch set with knobs and offset mechanism

4361.30.0BT

4361.31.0BT

4361.51.0BT

- Le mécanisme déporté permet un contact de la porte en fond de feuillure, et assure la continuité du joint au niveau de la serrure.

- Offset mechanism to allow compression of rebate strip.

Serrures et paumelles
Locksets and hinges

4363.0E*T

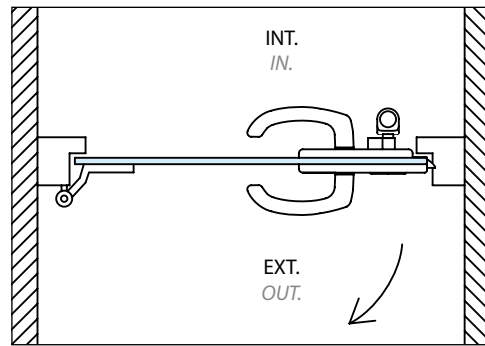
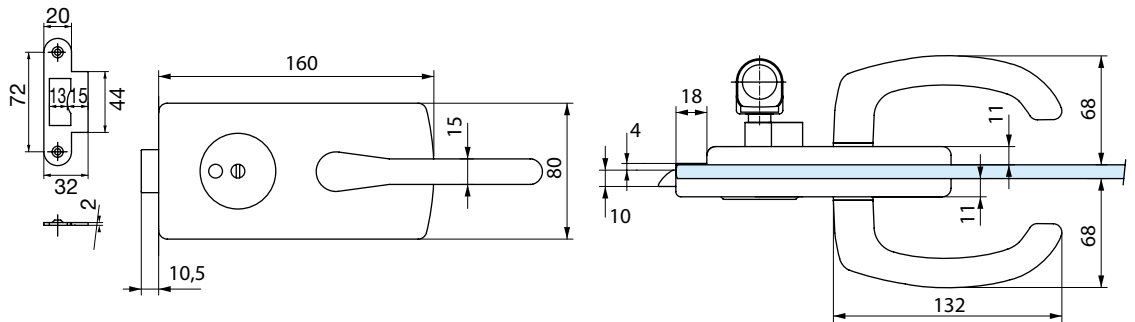
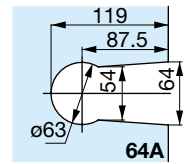

LES + PRODUITS

Mécanisme déporté

Idéal pour cabine et vestiaire

Sécurité : décondamnation d'urgence

Offset mechanism

Ideal for toilets and cloakrooms

Security : emergency exit

Références / References



Serrure avec voyant ouverture extérieure droite tirant
Lock with colour indicator outside opening right pull



Chromé brillant
Bright chromium



Chromé mat
Matt chromium

4363.30.0EDT 4363.31.0EDT

• Le mécanisme déporté permet un contact de la porte en fond de feuillure, et assure la continuité du joint au niveau de la serrure.

• Offset mechanism to allow compression of rebate strip.

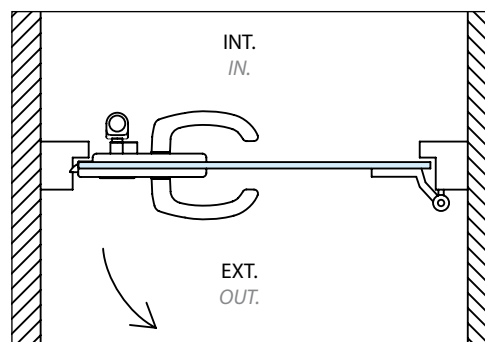

Références / References



Serrure avec voyant ouverture extérieure gauche tirant
Lock with colour indicator outside opening left pull



Chromé brillant
Bright chromium



Chromé mat
Matt chromium

4363.30.0EGT 4363.31.0EGT

• Le mécanisme déporté permet un contact de la porte en fond de feuillure, et assure la continuité du joint au niveau de la serrure.

• Offset mechanism to allow compression of rebate strip.

4363.0I*P

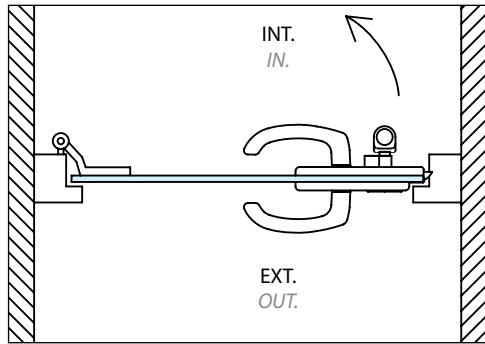
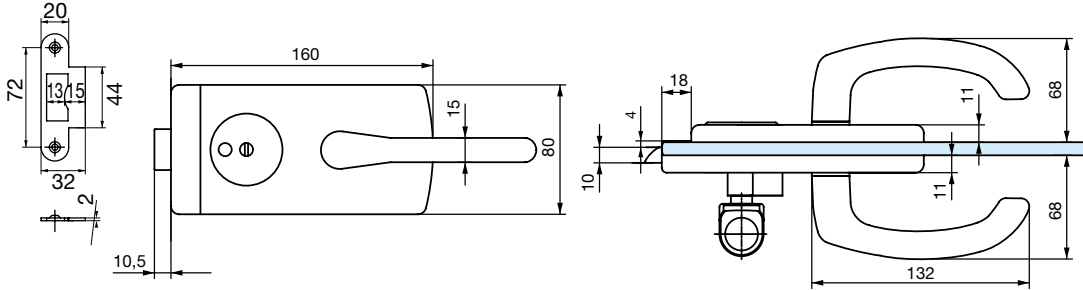
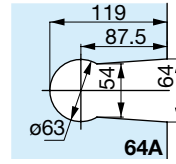

Références / References



Chromé brillant
Bright chromium



Chromé mat
Matt chromium

Serrure avec voyant ouverture intérieure droite poussant
Lock with colour indicator inside opening right push

4363.30.0IDP 4363.31.0IDP

- Le mécanisme déporté permet un contact de la porte en fond de feuillure, et assure la continuité du joint au niveau de la serrure.

- Offset mechanism to allow compression of rebate strip.

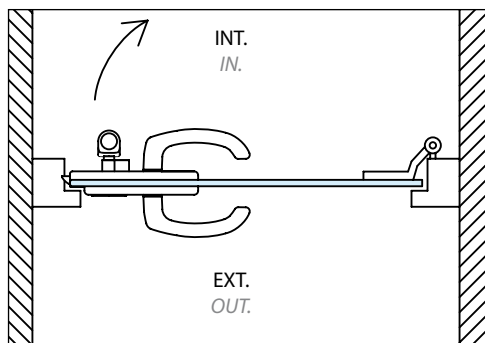

Références / References



Chromé brillant
Bright chromium



Chromé mat
Matt chromium

Serrure avec voyant ouverture intérieure gauche poussant
Lock with colour indicator inside opening left push

4363.30.0IGP 4363.31.0IGP

- Le mécanisme déporté permet un contact de la porte en fond de feuillure, et assure la continuité du joint au niveau de la serrure.

- Offset mechanism to allow compression of rebate strip.

Serrures et
paumelles
Locksets and
hinges

4367.0**

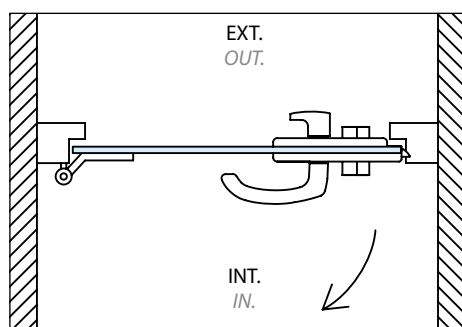
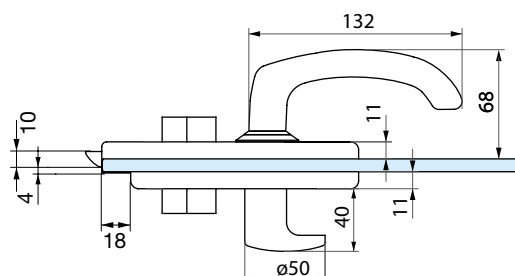
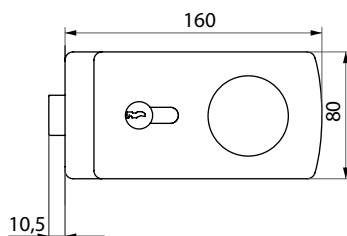
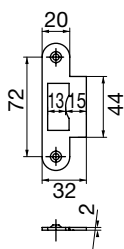
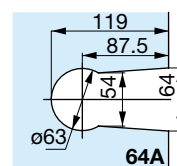

LES + PRODUITS

Mécanisme déporté

Offset mechanism

Références / References



Chromé brillant
Bright chromium



Chromé mat
Matt chromium

Serrure de milieu à cylindre et déport avec béquille intérieure et bouton fixe extérieur, condamnation sans avancement du pêne
Lock with euro profile cylinder and offset with handle inside fixed knob outside, without forward latch bolt motion

4367.30.0AD

4367.31.0AD

- Le mécanisme déporté permet un contact de la porte en fond de feuillure, et assure la continuité du joint au niveau de la serrure.

- Offset mechanism to allow compression of rebate strip.

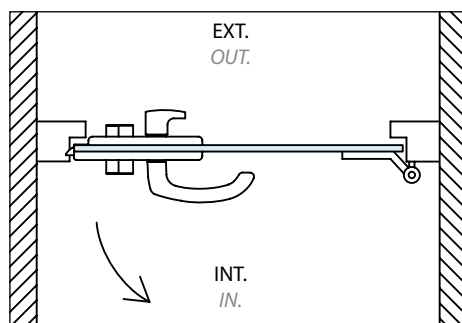

Références / References



Chromé brillant
Bright chromium



Chromé mat
Matt chromium

Serrure de milieu à cylindre et déport avec béquille intérieure et bouton fixe extérieur, condamnation sans avancement du pêne
Lock with euro profile cylinder and offset with handle inside fixed knob outside, without forward latch bolt motion

4367.30.0BC

4367.31.0BC

- Le mécanisme déporté permet un contact de la porte en fond de feuillure, et assure la continuité du joint au niveau de la serrure.

- Offset mechanism to allow compression of rebate strip.

4366

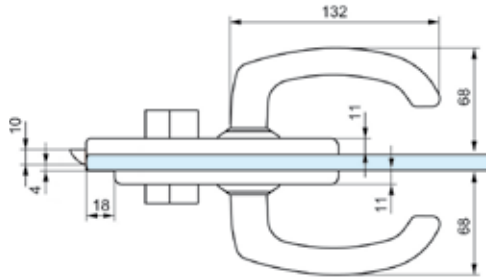
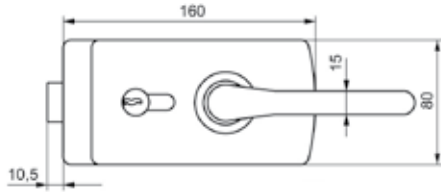
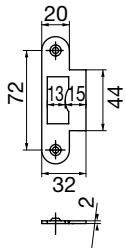
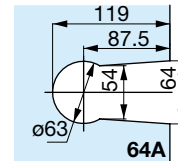

Références / References



Chromé mat
Matt chromium

Serrure de milieu à barillet et béquilles avec déport, condamnation sans avancement de pêne
Lock with euro profile cylinder offset and handles without forward motion of latch bolt

4366.31.0

- Le mécanisme déporté permet un contact de la porte en fond de feuillure, et assure la continuité du joint au niveau de la serrure.
- Offset mechanism to allow compression of rebate strip.



4380

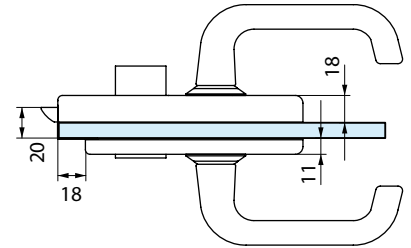
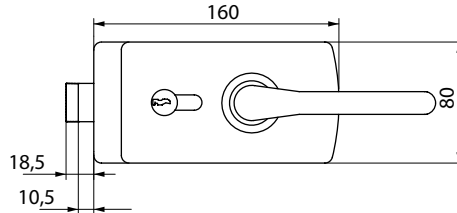
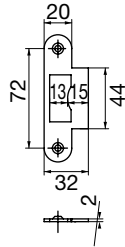
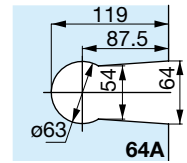

Références / References

Serrure de milieu à cylindre et béquilles avec dépôt, pêne désaxé, condamnation sans avancement de pêne
Lock set with handles, offset mechanism and spring bolt without forward motion of latch bolt



Chromé brillant
Bright chromium



Chromé mat
Matt chromium



Laqué blanc 9010
Lacquered white RAL 9010



4380.30.0

4380.31.0

4380.51.0



4380.31.4

- Le mécanisme déporté permet un contact de la porte en fond de feuillure, et assure la continuité du joint au niveau de la serrure.

- Offset mechanism to allow compression of rebate strip.

4381

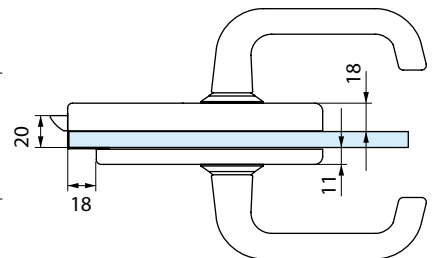
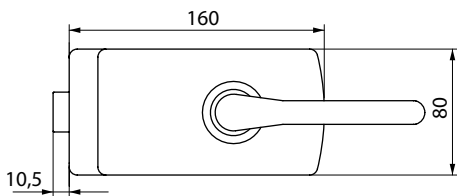
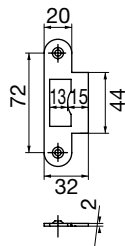
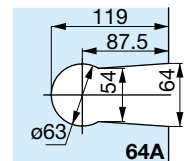

Références / References

Serrure de milieu bec de cane et béquilles avec dépôt, pêne désaxé,
Latch with with handles, offset mechanism and spring bolt



Chromé brillant
Bright chromium



Chromé mat
Matt chromium



Laqué blanc 9010
Lacquered white RAL 9010



4381.30.0

4381.31.0

4381.51.0

- Le mécanisme déporté permet un contact de la porte en fond de feuillure, et assure la continuité du joint au niveau de la serrure.

- Offset mechanism to allow compression of rebate strip.

4389

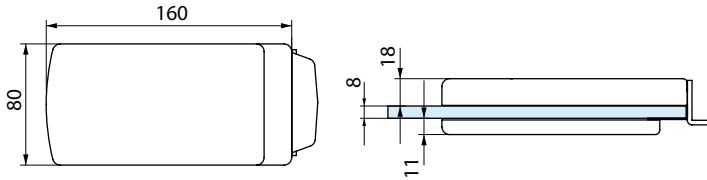
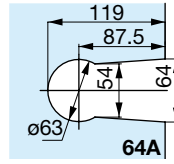

Serrures et
paumelles
Locksets and
hinges

Références / References



Boîtier gâche pour serrures série 4380 - 4381
Matching patch keep for locks series 4380 - 4381



Chromé brillant
Bright chromium



Chromé mat
Matt chromium

4389.30.0

4389.31.0

KITS SERRURE / KIT LOCK



Visuel non contractuel - contenu peut varier
Photo non contractuel - contents can differ.

Références / References

Kit complet / Complete Kit



Chromé brillant
Bright chromium



Chromé mat
Matt chromium



Laqué Blanc
Lacquered white

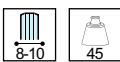

Kit serrure 4300 + 2 paumelles 4200 et 2 fiches 3206
Kit lock 4300 + 2 hinges 4200 and 2 butts 3206

4300.30.0K

4300.31.0K

4300.51.0K



Kit serrure 4301 + 2 paumelles 4200 et 2 fiches 3206
Kit lock 4301 + 2 hinges 4200 and 2 butts 3206

4301.30.0K

4301.31.0K

4301.51.0K



Kit serrure 4360 + 2 paumelles et fiches 4203
Kit lock 4360 + 2 hinges and butts 4203

4360.30.0K

4360.31.0K

4360.51.0K

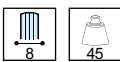

Kit serrure 4361 + 2 paumelles et fiches 4203
Kit lock 4361 + 2 hinges and butts 4203

4361.30.0K

4361.31.0K

4361.51.0K

Serrures *Locksets*

Artis Glass lock

Caractéristiques techniques générales

- Montage sur encoche 64A
- Réversible
- À cylindre européen panneton DIN
- Rappel du pêne à la clé
- Pour porte en verre trempé de 8 mm
- Livrée avec gâche plate et 3 clés

Résistance

- Performance : Conforme à la norme EN 12209 Grade B, certifié TÜV
- Anti-Corrosion : Conforme à la norme NF EN 1670 Grade 3

Esthétique

- Nouvelle finition : Chromé diamant noir
- Design coordonné avec les paumelles 4203
- Haute qualité du traitement de surface garantissant un rendu irréprochable

Isolation thermique et acoustique

- Contact de la porte avec le joint de l' huisserie

Développement durable

- ISO 14001

Garantie

- 5 ans

General technical features

- To fit notch 64A
- Reversible
- European profile cylinder
- Return of latch bolt by key
- For toughened glass doors 8 mm thick
- Supplied with flat keep and 3 keys

Résistance

- Performance: Complies with norm EN12209 Grade B, TÜV certified
- Anti-Corrosion: Complies with norm NF EN1670 Grade 3

Design

- New finish: Black diamond chromium
- Design coordinated with hinges series 4203
- High quality surface treatment guaranteed to give an impeccable finish

Thermal insulation and soundproofing

- Contact with the door and the frame seal

Sustainability

- ISO 14001

Guarantee

- 5 years

LES + PRODUITS

The + product

Design

Certifié TUV

Nombreuses
versions

Réversible

Elegant Design

TUV certified

Large variety
of models

Reversible

4400



ENCOCHE 64A

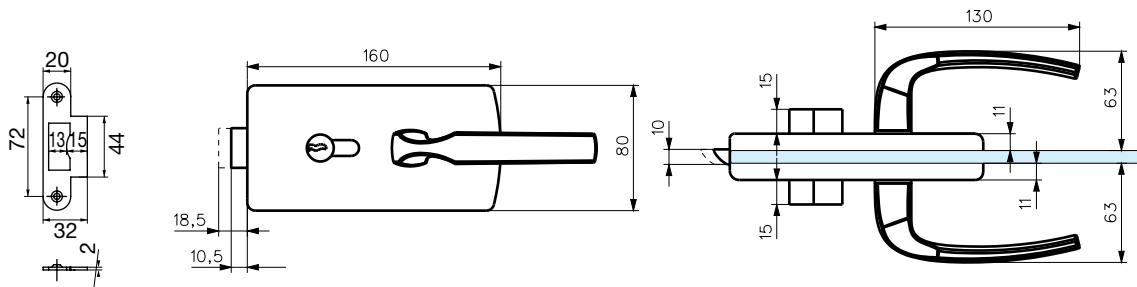
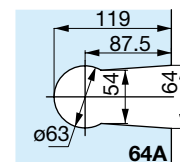

Références / References



Diamant noir
Black Diamond



Chromé brillant
Bright chromium



Chromé mat
Matt chromium

Serrure de milieu à cylindre et double béquilles
Lock with euro profile cylinder and pair of handles

4400.23.0

4400.30.0

4400.31.0

4401



ENCOCHE 64A

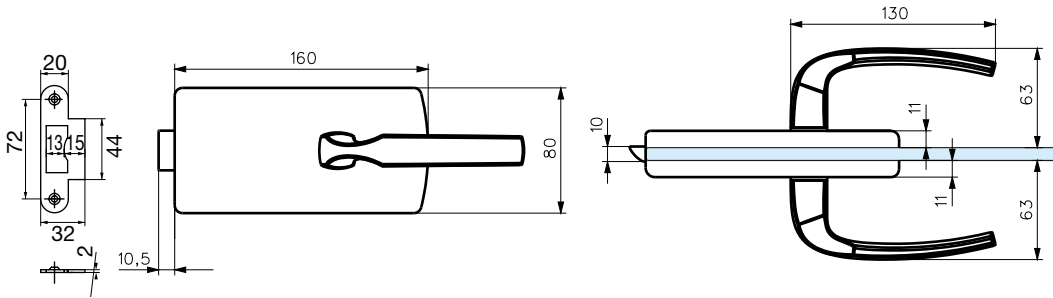
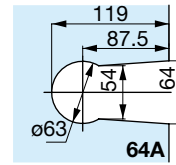

Références / References



Serrure de milieu bec de cane et double béquilles
Latch set with pair of handles



Diamant noir
Black Diamond



Chromé brillant
Bright chromium



Chromé mat
Matt chromium

4401.23.0

4401.30.0

4401.31.0

4309.**.0

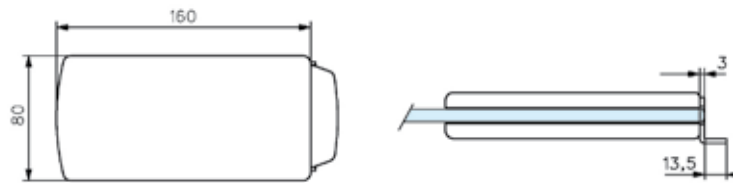
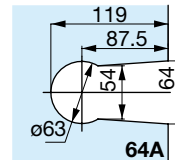

Références / References

Boîtier gâche pour serrures
séries 4300 et 4400
Matching patch keep for locks series
4300 and 4400



Diamant noir
Black Diamond



Chromé brillant
Bright chromium



Chromé mat
Matt chromium

4309.23.0

4309.30.0

4309.31.0

Serrures et
paumelles
Locksets and
hinges

4460



ENCOCHE 64A

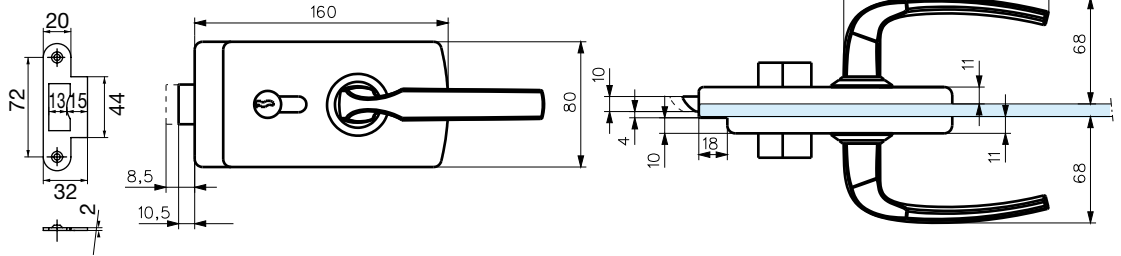
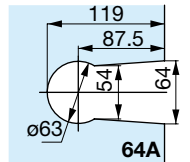

Références / References



Diamant noir
Black Diamond



Chromé brillant
Bright chromium



Chromé mat
Matt chromium

Serrure de milieu à cylindre et béquilles avec déport, pêne axé
Lock with euro profile cylinder, handles and offset mechanism

4460.23.0

4460.30.0

4460.31.0

- Le mécanisme déporté permet un contact de la porte en fond de feuillure, et assure la continuité du joint au niveau de la serrure.

- Offset mechanism to allow compression of rebate strip.

4461



ENCOCHE 64A

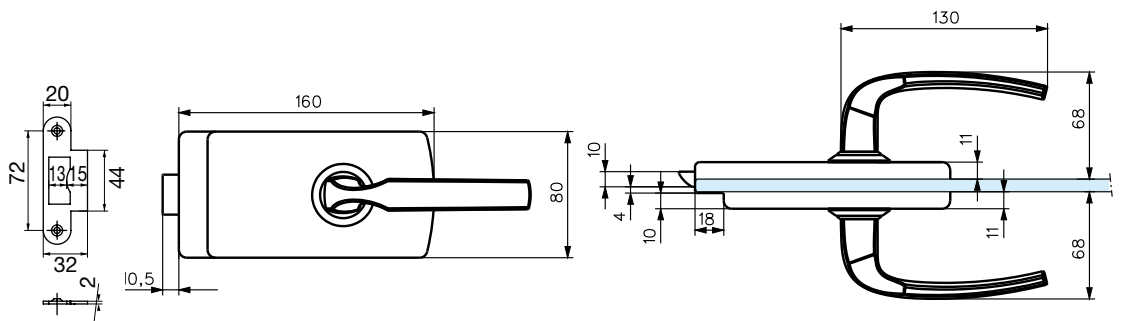
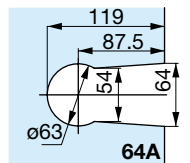

Références / References



Diamant noir
Black Diamond



Chromé brillant
Bright chromium



Chromé mat
Matt chromium

Serrure de milieu bec de cane et béquilles avec déport, pêne axé
Latch set with handles and offset mechanism

4461.23.0

4461.30.0

4461.31.0

- Le mécanisme déporté permet un contact de la porte en fond de feuillure, et assure la continuité du joint au niveau de la serrure.

- Offset mechanism to allow compression of rebate strip.

LES + PRODUITS

The + product

Design

Certifié TUV

Nombreuses versions

Réversible

Elegant Design

TUV certified

Large variety of models

Reversible

4480



ENCOCHE 64A

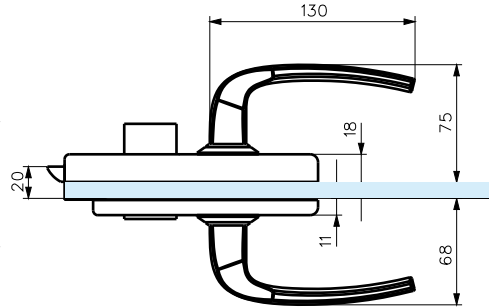
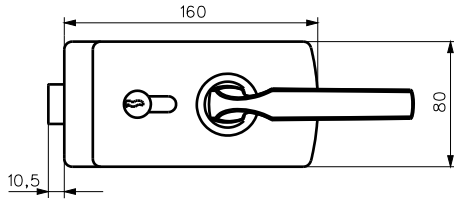
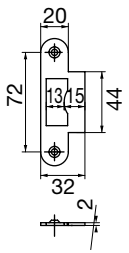
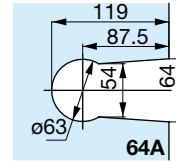

Références / References



Diamant noir
Black Diamond



Chromé brillant
Bright chromium



Chromé mat
Matt chromium

Serrure de milieu à cylindre et béquilles avec déport, pêne désaxé, condamnation sans avancement de pêne

Lock set with handles, offset mechanism and spring bolt without forward motion of latch bolt

4480.23.0

4480.30.0

4480.31.0

- Le mécanisme déporté permet un contact de la porte en fond de feuillure, et assure la continuité du joint au niveau de la serrure.

- Offset mechanism to allow compression of rebate strip.

4481



ENCOCHE 64A

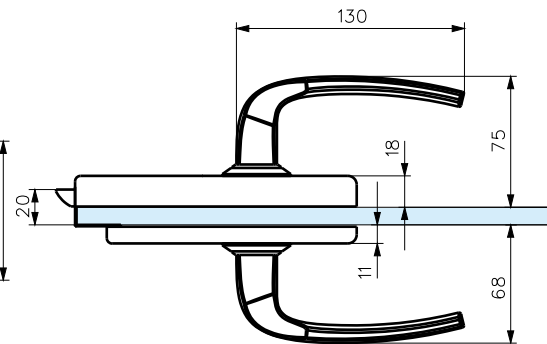
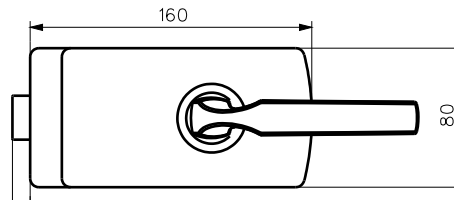
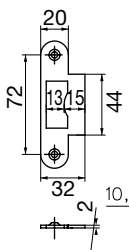
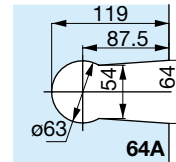

Références / References



Diamant noir
Black Diamond



Chromé brillant
Bright chromium



Chromé mat
Matt chromium

Serrure de milieu bec de cane et béquilles avec déport, pêne désaxé,

Latch with with handles, offset mechanism and spring bolt,

4481.23.0

4481.30.0

4481.31.0

- Le mécanisme déporté permet un contact de la porte en fond de feuillure, et assure la continuité du joint au niveau de la serrure.

- Offset mechanism to allow compression of rebate strip.

Bastille

Caractéristiques techniques

- Pour verre trempé de 8 – 10 et 12 mm
- Montage sur encoche 6300EX
- Réversible
- A cylindre européen panneton DIN (norme DIN 18254)
- Avec caches cylindre
- Rappel du pêne à la clé
- Condamnation avec avancement du pêne
- Possibilités de combinaison avec passe général
- Livrée avec gâche plate et 3 clés

Technical features

- For 8 -10 and 12 mm thick toughened glass
- To fit notch 6300EX
- Reversible
- European profile cylinder (DIN standard 18254)
- With cylinder covers
- Return of the latch bolt by key
- Locked with forward motion of latch bolt
- Possibility of combinations with master key
- Supplied with flat keep and 3 keys

- **Le mécanisme déporté permet un contact de la porte en fond de feuillure, et assure la continuité du joint au niveau de la serrure.**

- **Offset mechanism to allow compression of rebate strip.**

LES + PRODUITS

The + product

Design épuré

Certifié TUV

Grande qualité de finition

Mécanisme de précision

Réversible

Refined design

TUV certified

High quality finishes

Precision mechanics

Reversible



4501

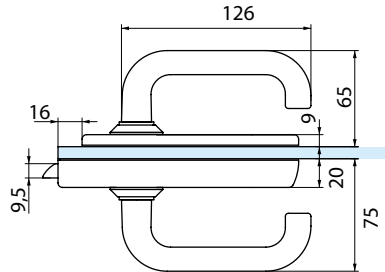
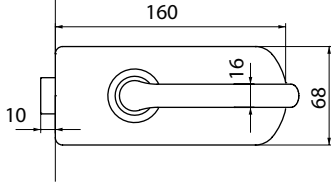
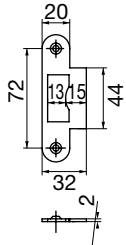
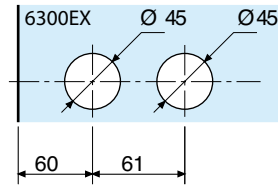

Références / References



Serrure de milieu bec de cane et béquilles
Latch set with pair of handles



Chromé brillant
Bright chromium



Chromé mat
Matt chromium

4501.30.0

4501.31.0

4550.**.*

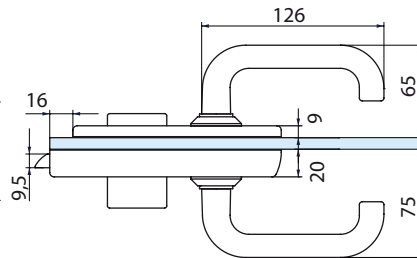
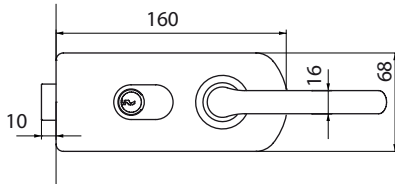
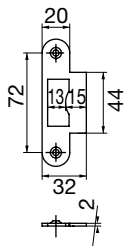
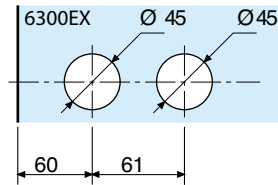

Références / References

Serrure de milieu à cylindre et double
béquilles, caches cylindre
Lock with euro profile
cylinder, pair of handles
and cylinder cover



Chromé brillant
Bright chromium



Chromé mat
Matt chromium



4550.30.0

4550.31.0



4550.30.4

4550.31.4



4550.30.5

4550.31.5

4555.**.0

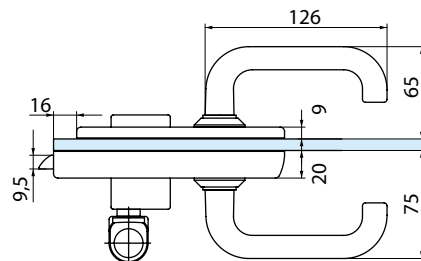
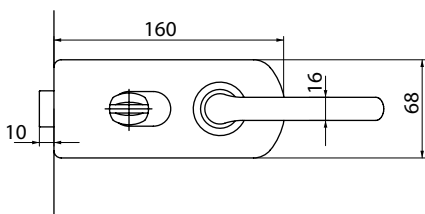
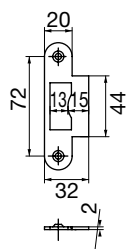
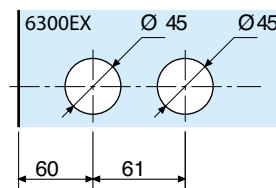

Références / References

Serrure de milieu avec cylindre à bouton et double béquilles, caches cylindre

Lock with thumb turn cylinder, pair of handles and cylinder cover



Chromé brillant
Bright chromium



Chromé mat
Matt chromium



4555.30.0

4555.31.0



4555.30.4

4555.31.4



4555.30.5

4555.31.5

4509

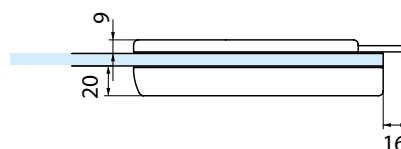
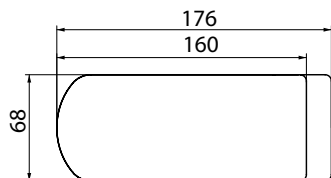
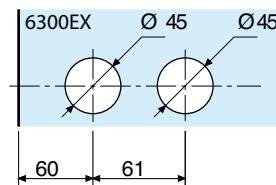

Références / References



Chromé brillant
Bright chromium



Chromé mat
Matt chromium

Boîtier gâche pour serrures série 4500

Matching patch keep for locks series 4500

4509.30.0

4509.31.0



Lumira

Caractéristiques techniques

- Pour verre trempé de 8, 10 et 12 mm
- Montage sur encoche 6300EX
- Réversible
- Condamnation par clé avec avancement du pêne
- Rappel du pêne tour à la clé
- Livré avec gâche plate

Technical features

- For 8- 10 and 12 mm thick toughened glass
- To fit notch 6300EX
- Reversible
- Locked by key with forward motion of latch bolt
- Retractable latch bolt by key
- Supplied with flat keep

LES + PRODUITS

The + product

Mécanisme
déporté

Résistance à l'usage
intensif

Nombreuses
versions

Offset mechanism

Resistance
to heavy use

Large variety
of models

V525

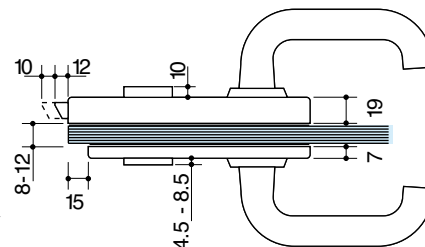
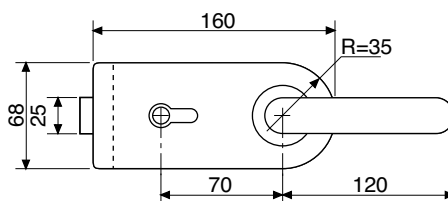
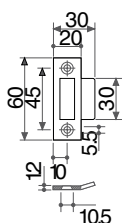
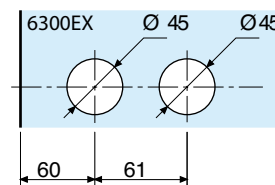

Références / References



Serrure de milieu avec cylindre Européen
avec béquilles
Lock with euro profile cylinder and handles

Aluminium anodisé Argent Brossé
Brushed anodised alu silver

V525.12

- Le mécanisme déporté permet un contact de la porte en fond de feuillure, et assure la continuité du joint au niveau de la serrure.

- Offset mechanism to allow compression of rebate strip.

V526

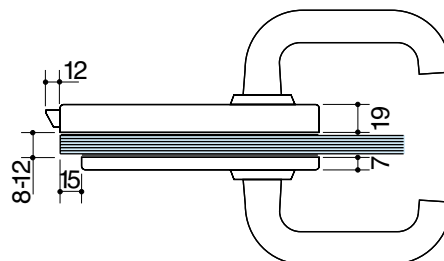
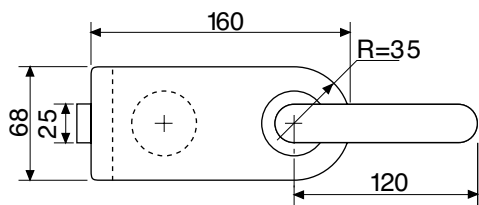
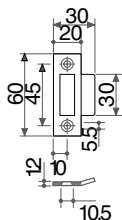
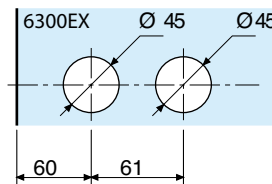

Références / References



Serrure de milieu avec béquille
Latch set with handles



Aluminium anodisé Argent Brossé
Brushed anodised alu silver

V526.12

- Le mécanisme déporté permet un contact de la porte en fond de feuillure, et assure la continuité du joint au niveau de la serrure.

- Offset mechanism to allow compression of rebate strip.

V350

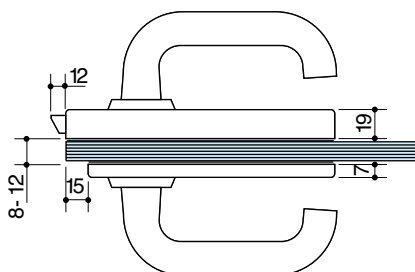
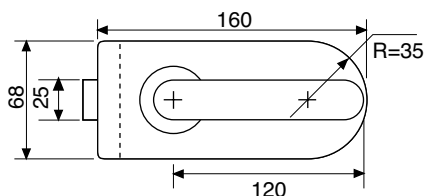
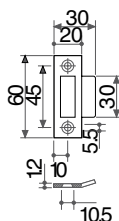
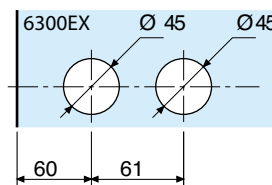

Références / References



Serrure de milieu avec béquilles
Latch set with handles



Aluminium anodisé Argent Brossé
Brushed anodised alu silver

V350.12

- Le mécanisme déporté permet un contact de la porte en fond de feuillure, et assure la continuité du joint au niveau de la serrure.

- Offset mechanism to allow compression of rebate strip.

V310

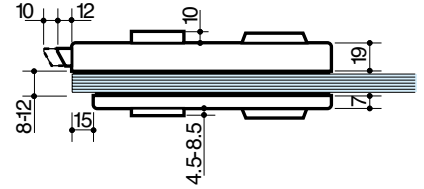
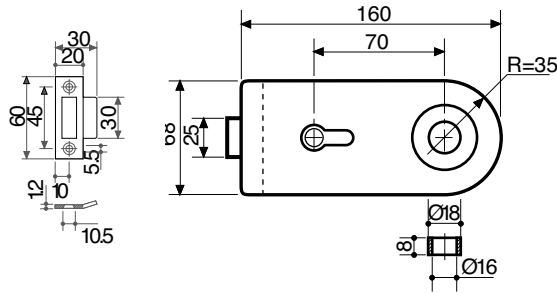
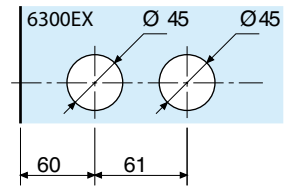

Références / References



Serrure de milieu sans cylindre et pour bouton ou double béquilles
Lock without cylinder and pair of handles or knobs



Aluminium anodisé Argent Brossé
Brushed anodised alu silver



Inox Brossé
Brushed stainless steel



Aluminium anodisé Aninox
Brushed anodised alu.

V310.12

V310.15

V310.36

- Le mécanisme déporté permet un contact de la porte en fond de feuillure, et assure la continuité du joint au niveau de la serrure.

- *Offset mechanism to allow compression of rebate strip.*

V330

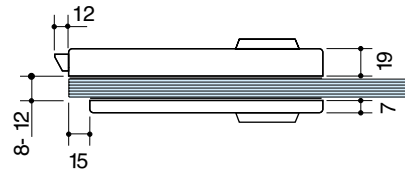
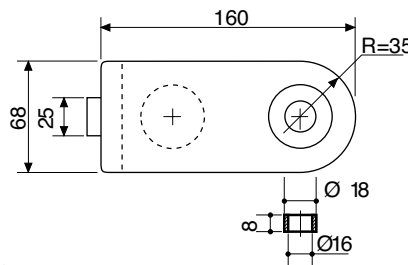
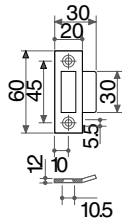
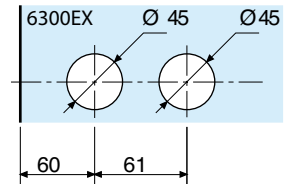

Références / References



Serrure de milieu sans béquille
Latch set without handles



Aluminium anodisé Argent Brossé
Brushed anodised alu silver



Inox Brossé
Brushed stainless steel



Aluminium anodisé Aninox
Brushed anodised alu.

V330.12

V330.15

V330.36

- Le mécanisme déporté permet un contact de la porte en fond de feuillure, et assure la continuité du joint au niveau de la serrure.

- *Offset mechanism to allow compression of rebate strip.*

V340

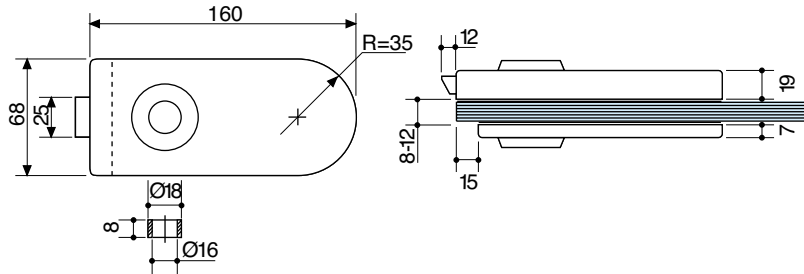
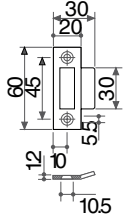
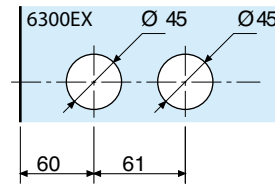

Références / References



Serrure de milieu sans béquille
Latch set without handles



Aluminium anodisé Argent Brossé
Brushed anodised alu silver



Inox Brossé
Brushed stainless steel



Aluminium anodisé Aninox
Brushed anodised alu.

V340.12

V340.15

V340.36

- Le mécanisme déporté permet un contact de la porte en fond de feuillure, et assure la continuité du joint au niveau de la serrure.

- Offset mechanism to allow compression of rebate strip.

V527

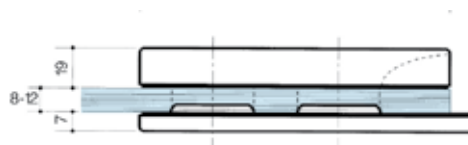
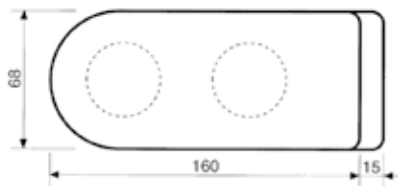
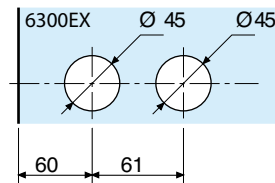

Références / References



Boîtier Gâche pour serrure de milieu série Lumira horizontale.
Matching patch keep for lock series Lumira horizontal



Aluminium anodisé Argent Brossé
Brushed anodised alu silver



Inox Brossé
Brushed stainless steel



Aluminium anodisé Aninox
Brushed anodised alu.

V527.12

V527.15

V527.36

V750

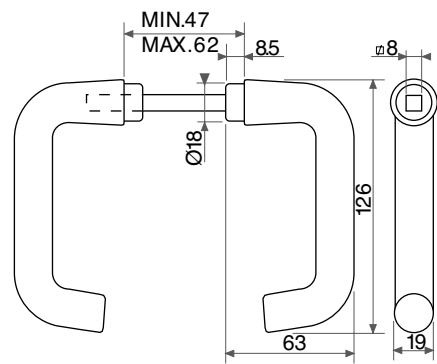

Aluminium anodisé Argent Brossé
Brushed anodised alu silver

Inox Brossé
Brushed stainless steel

V750.12

V750.15

Références / References

Paire de béquilles forme ronde
pour V310, V320, V330 et V340
Pair of lever handles rounded design
for V310, V320, V330 and V340



V525.5.**

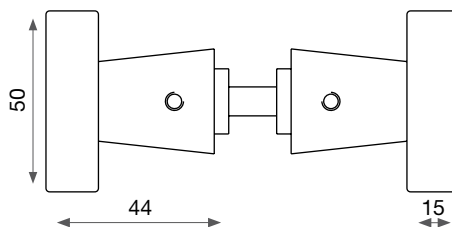

Aluminium anodisé Argent Brossé
Brushed anodised alu silver

V525.5.12

Références / References

Paire de boutons pour V310, V320, V330 et V340
Pair of door knobs for V310, V320, V330 and V340

V554.2

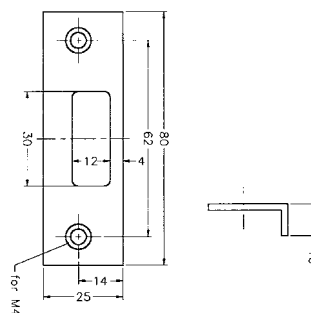

Inox Brossé
Brushed stainless steel

V554.2.15

Références / References

Gâche pour V310, V320, V330 et V340 type allemand
Keep plate for V310, V320, V330 and V340 german style

4391.00.0

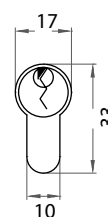
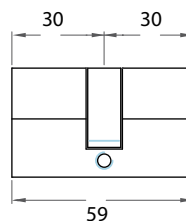

Références / References



Cylindre Européen 30/30 mm
Europrofile cylinder 30/30 mm

4391.00.0

V533.1

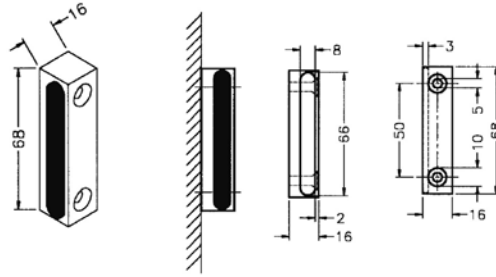

Laiton poli verni
Polished varnished brass



Aluminium anodisé Argent Brossé
Brushed anodised alu silver



Chromé brillant
Bright chromium



Chromé mat brossé
Brushed matt chromium



Aluminium anodisé Aninox
Brushed anodised alu.

Références / References

Butée pour serrure de milieu Wall stop for locks	V533.1.01	V533.1.12	V533.1.30	V533.1.33	V533.1.36
---	------------------	------------------	------------------	------------------	------------------

KITS SERRURE / KIT LOCK



Visuel non contractuel - contenu peut varier
Photo non contractual - contents can differ.



Références / References

Kit complet / Complete Kit



Aluminium anodisé Argent Brossé
Brushed anodised alu silver



Aluminium anodisé Aninox
Brushed anodised alu.

 	Kit serrure V525 + 2 paumelles V505.2 et 2 caches fiches 4205 Kit lock V525 + 2 hinges V505.2 and 2 covers for butt 4205	V525.12K	V525.36K
 	Kit serrure V526 + 2 paumelles V505.2 et 2 caches fiches 4205 Kit lock V526 + 2 hinges V505.2 and 2 covers for butt 4205	V526.12K	V526.36K
 	Kit serrure V350 + 2 paumelles V505.2 et 2 caches fiches 4205 Kit lock V350 + 2 hinges V505.2 and 2 covers for butt 4205	V350.12K	V350.36K
 	Kit contre boîtier V527 + 2 paumelles V505.2 et 2 caches fiches 4205 Kit matching patch keep V527 + 2 hinges V505.2 and 2 covers for butt 4205	V527.12K	
 	Kit serrure V525 + 2 paumelles V505 Kit lock V525 + 2 hinges V505	V525.12KB	V525.36KB
 	Kit serrure V526 + 2 paumelles V505 Kit lock V526 + 2 hinges V505	V526.12KB	
 	Kit serrure V350 + 2 paumelles V505 Kit lock V350 + 2 hinges V505	V350.12KB	V350.36KB
 	Kit contre boîtier V527 + 2 paumelles V505 Kit matching patch keep V527 + 2 hinges V505	V527.12KB	
 	Kit serrure V525 + 2 paumelles V506 Kit lock V525 + 2 hinges V506	V525.12KA	V525.36KA
 	Kit serrure V350 + 2 paumelles V506 Kit lock V350 + 2 hinges V506	V350.12KA	V350.36KA

Serrures et paumelles
Locksets and hinges

Vertis

Caractéristiques techniques

- Pour verre trempé de 8, 10 et 12 mm
- Montage sur encoche V370E
- Avec pêne demi tour et pêne dormant

Technical features

- For 8-10 and 12 mm thick toughened glass
- To fit notch V370E
- With spring and dead bolt



LES + PRODUITS

The + product

Grande qualité
de finition

Résistance à l'usage
intensif

Sécurité accrue

High quality finishes

Resistance
to heavy use

Increased security



V360

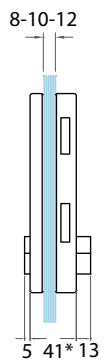
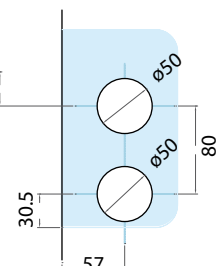
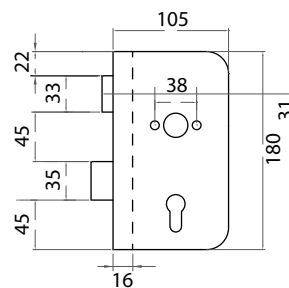
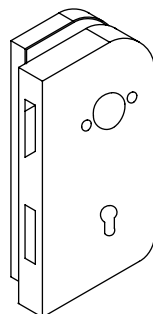

Références / References



Serrure de milieu pour cylindre Européen sans béquille, DIN droite
Lock for Euro profile cylinder without handles DIN right

V360.12

V360.15

- Prévoir : Gâche plate V2140 ou V2140.2
Cylindre 4391.00.0
Béquilles V770 ou V780

- Allow for flat keep V2140 or V2140.2
Cylinder 4391.00.0
Handles V770 ou V780

Aluminium anodisé Argent Brossé
Brushed anodised alu silver

Inox Brossé
Brushed stainless steel

V370

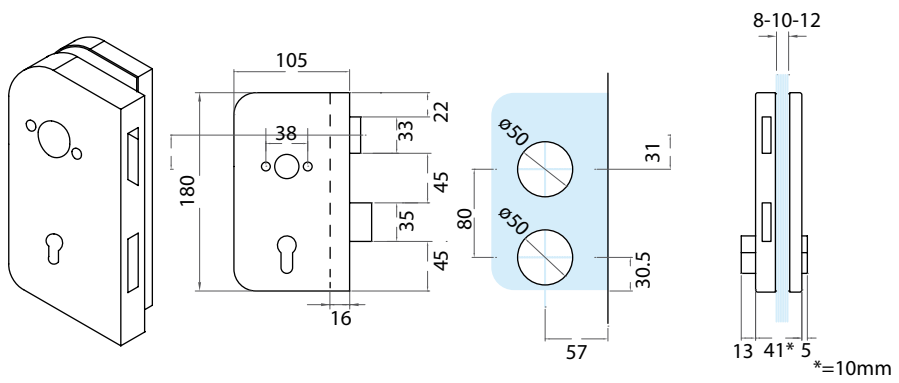

Serrures et
paumelles
Locksets and
hinges

Références / References



Serrure de milieu pour cylindre Européen sans béquille, DIN gauche
Lock for Euro profile cylinder without handles DIN left

V370.12

V370.15

- Prévoir : Gâche plate V2140 ou V2140.2
Cylindre 4391.00.0
Béquilles V770 ou V780

- Allow for flat keep V2140 or V2140.2
Cylinder 4391.00.0
Handles V770 ou V780

V367

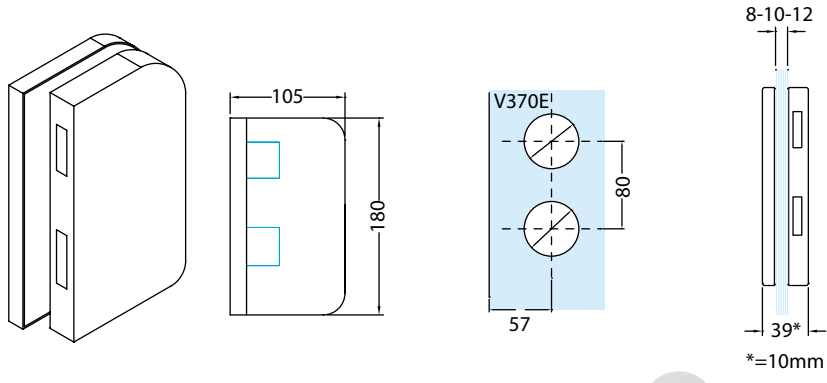

Références / References



Boîtier gâche pour serrure de milieu pour V370 / DIN droite
Matching patch keep for lock V370 / DIN right

V367.12

V367.15

V377

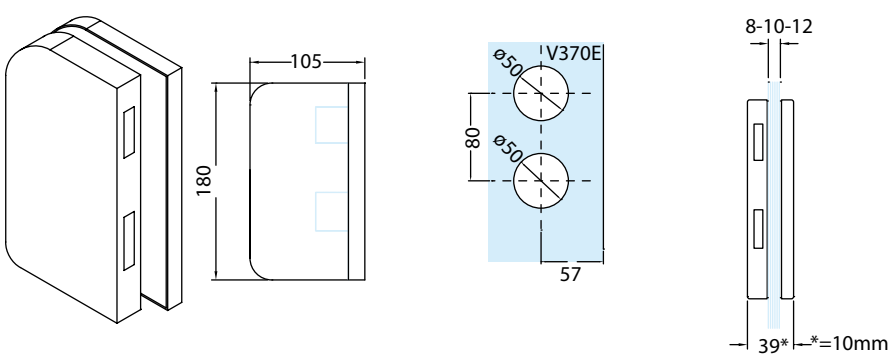

Références / References



Boîtier gâche pour serrure de milieu pour V360 / DIN gauche
Matching patch keep for centre lock V360 / DIN left

V377.12

V377.15

Serrures et
paumelles
*Locksets and
hinges*

Vertis SQ

Caractéristiques techniques

- Pour verre trempé de 8, 10 et 12 mm
- Montage sur encoche V370E
- Avec pêne demi tour et pêne dormant

Technical features

- For 8-10 and 12 mm thick toughened glass
- To fit notch V370E
- With spring and dead bolt



LES + PRODUITS

The + product

Grande qualité
de finition

Résistance à l'usage
intensif

Sécurité accrue

High quality finishes

*Resistance
to heavy use*

Increased security



V360SQ

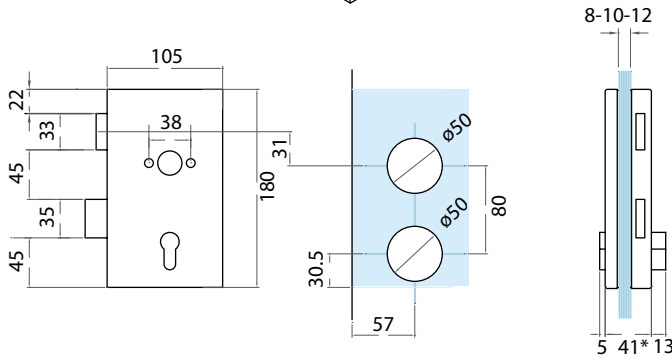
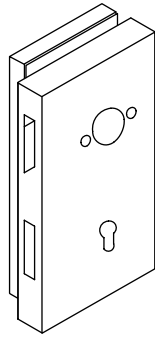

*=10mm



Inox Brossé
Brushed stainless steel

Références / References



Serrure de milieu pour cylindre Européen sans béquille, DIN droite
Lock for Euro profile cylinder without handles DIN right

V360SQ.15

- Prévoir : Gâche plate V2140 ou V2140.2
Cylindre 4391.00.0
Béquilles V770 ou V780

- Allow for flat keep V2140 or V2140.2
Cylinder 4391.00.0
Handles V770 ou V780

V370SQ

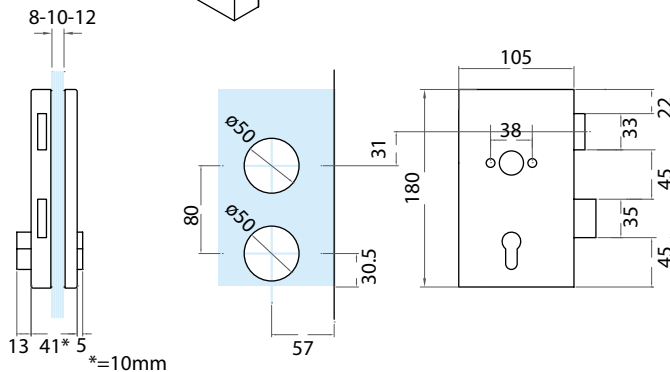
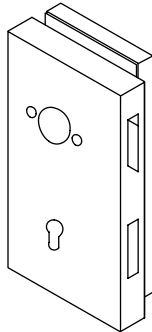

*=10mm



Inox Brossé
Brushed stainless steel

Références / References



Serrure de milieu pour cylindre Européen sans béquille, DIN gauche
Lock for Euro profile cylinder without handles DIN left

V370SQ.15

- Prévoir : Gâche plate V2140 ou V2140.2
Cylindre 4391.00.0
Béquilles V770 ou V780

- Allow for flat keep V2140 or V2140.2
Cylinder 4391.00.0
Handles V770 ou V780

V770

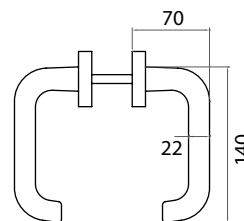

Références / References

Paire de béquilles avec rosace pour V360, V370, V360SQ et V370SQ
Pair of lever handles with rosettes for V360, V370, V360SQ et V370SQ

V770.12

V770.15



V780

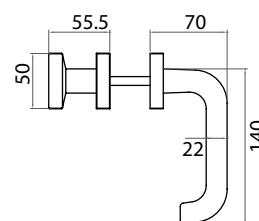

Références / References

Bouton fixe / béquille pour V360, V370, V360SQ et V370SQ
Combination fixed knob / lever handle for V360, V370, V360SQ et V370SQ

V780.12

V780.15

V2140

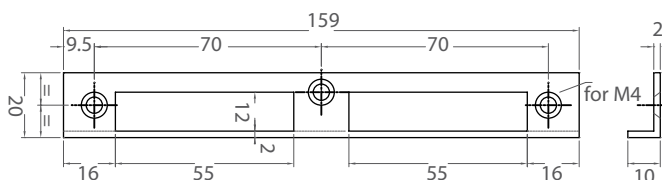

Références / References

Gâche forme L pour V360, V370
Keep plate L shape for V360, V370

V2140.15

V2140.2

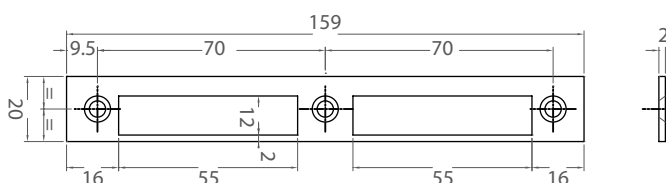

Références / References

Gâche pour V360, V370
Keep plate for V360, V370

V2140.2.15

4391.00.0

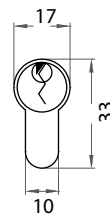
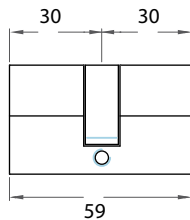

Serrures et
paumelles
Locksets and
hinges

Références / References

Cylindre Européen 30/30 mm (Norme EN1303 - DIN NF 040)
Europrofile cylinder 30/30 mm

4391.00.0

V533.1

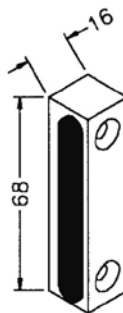

Laiton poli verni
Polished varnished brass



Aluminium anodisé Argent Brossé
Brushed anodised alu silver



Chromé brillant
Bright chromium



Chromé mat brossé
Brushed matt chromium



Aluminium anodisé Aninox
Brushed anodised alu.

Références / References

Butée pour serrure de milieu
Wall stop for lock

V533.1.01

V533.1.12

V533.1.30

V533.1.33

V533.1.36

2881.15.0



Inox Brossé
Brushed stainless steel

Références / References

Butée de porte Ø 35 mm hauteur 40 mm
Door stop 35 Ø X 40 mm height

2881.15.0

Serrures et
paumelles
*Locksets and
hinges*

Classic



Caractéristiques techniques

- Pour verre trempé de 8, 10 mm
- Montage sur encoche 64A avec cale d'encoche et sur les anciennes encoches 60A, 60B, 64
- Réversible par retournement du pêne demi-tour pour adaptation selon sens d'ouverture de la porte
- Pêne demi tour et pêne dormant indépendants
- A cylindres avec protection par bagues tournantes
- Rappel du demi-tour à la clé
- Livré avec gâche plate, 3 clés et cale d'encoche

Technical features

- For 8 and 10 mm thick toughened glass
- To fit notch 64A with notch wedge supplied and on notches 60A, 60B and 64
- Reversible by altering latch bolt to adapt to the opening direction of the door
- Individual latch and dead bolt
- Protected cylinder
- Return of latch bolt with moring collar
- Supplied with flat keep, 3 keys and notch wedge

LES + PRODUITS

The + product

Grande qualité
de finition

Compatible
anciennes encoches

Sécurité :
pêne dormant
indépendant

High quality finishes

*Compatible with long
standing notches*

*Security :
independant bolt*



1300

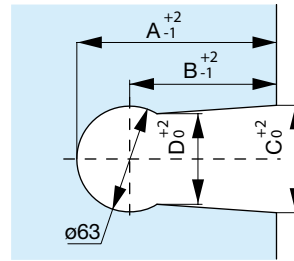

Encoche	A	B	C	D
60A	94,5	62	62	51
60B	94,5	63	65	57
64	110	78,5	65	54
64A	119	87,5	64	54

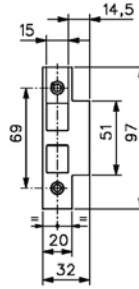
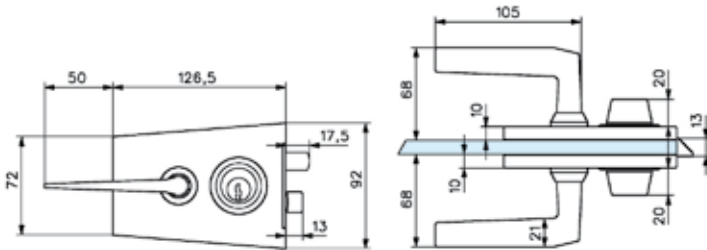

Références / References



Serrure de milieu à cylindre et double béquilles
Lock with cylinder and double handles



Chromé brillant
Bright chromium

1300.30.0



Chromé mat
Matt chromium

1300.31.0

1309

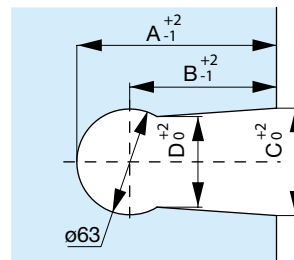

Encoche	A	B	C	D
60A	94,5	62	62	51
60B	94,5	63	65	57
64	110	78,5	65	54
64A	119	87,5	64	54

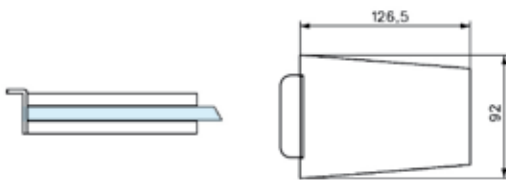

Références / References



Boîtier gâche pour serrures série 1300
Matching patch keep for locks series 1300



Chromé brillant
Bright chromium

1309.30.0



Chromé mat
Matt chromium

1309.31.0

Open Glass

Caractéristiques techniques

- Kit de transformation d'une porte en bois par une porte en verre.
- Pour verre trempé de 8 mm
- Hauteur maxi dans la feuillure 2200 mm
- Largeur maxi dans la feuillure 1000 mm
- Pour des feuillures de 35 à 48 mm de profondeur

Technical features

- Kit for transformation of wooden door to glass door
- Pour verre trempé de 8 mm
- Maximum height in the frame 2200 mm
- Maximum width in the frame 1000 mm
- For frames of 35 to 48 mm in depth

LES + PRODUITS

Design
Confort
Simplicité
et rapidité de pose

Design
User comfort
Quick and easy
assembling

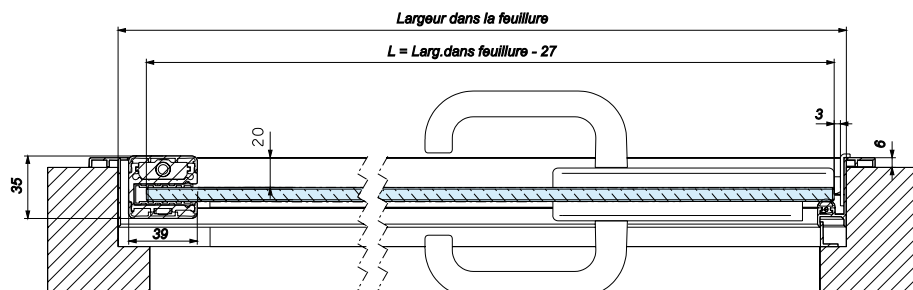
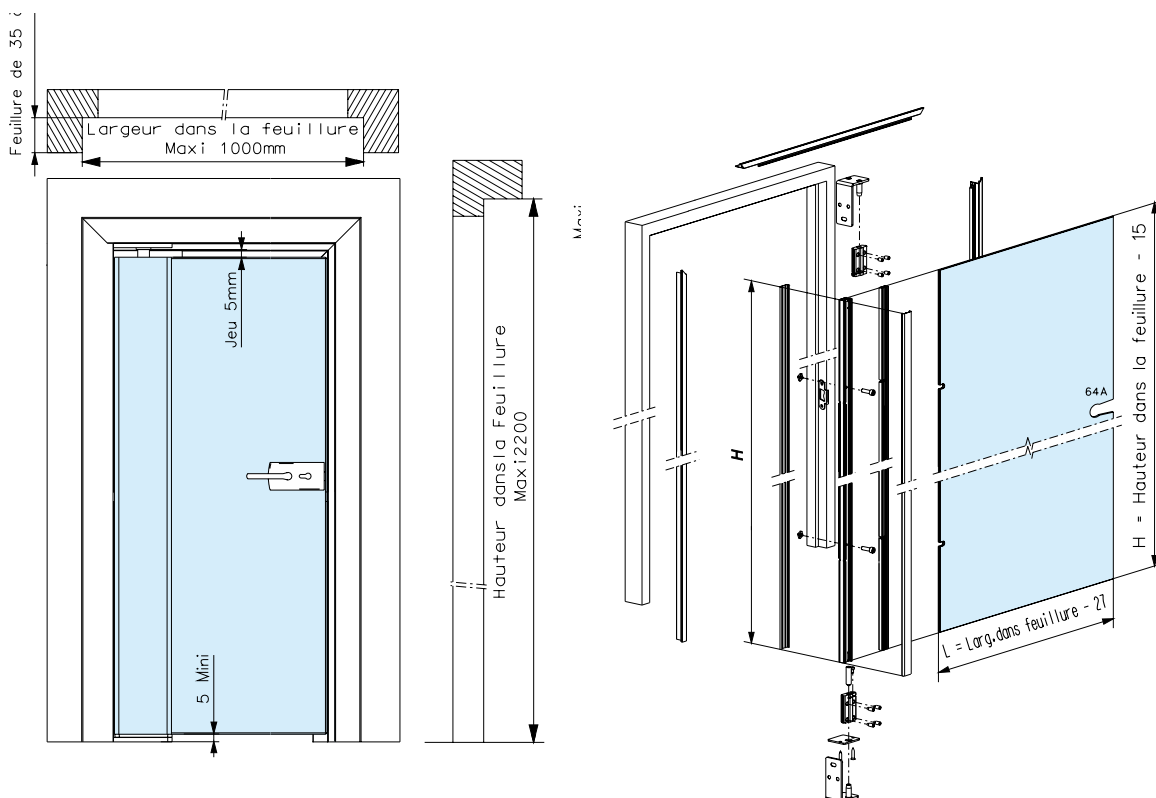

Références / References



Aluminium anodisé Argent Brossé
Brushed anodised alu silver

Laqué blanc 9010
Lacquered white RAL 9010

Kit rénovation pour porte intérieure
Renovation kit for interior door

KPR01/08.12

KPR01/08.51



Ce kit comprend

- 2 Profils verticaux lg 2200 mm et 1 profil horizontal lg 1000 mm pour l'habillage du bâtis.
- 5 mètres de joint périphérique
- 1 Profil articulé avec capots et pivots Haut et Bas intégrés
- Livré avec vis de fixation et gâche plate spécifique pour serrure réf: 4360.**.0 et 4361.**.0

This kit includes

- 2 vertical profiles 2200 mm in length and 1 horizontal profile 1000 mm in length for the casing
- 5 metres of seal for frame
- 1 hinged profile with top and bottom integrated pivots and cover
- Delivered with fixing screws and flat strike plate compatible with the lock ref 4360.**.0 and 4361.**.0

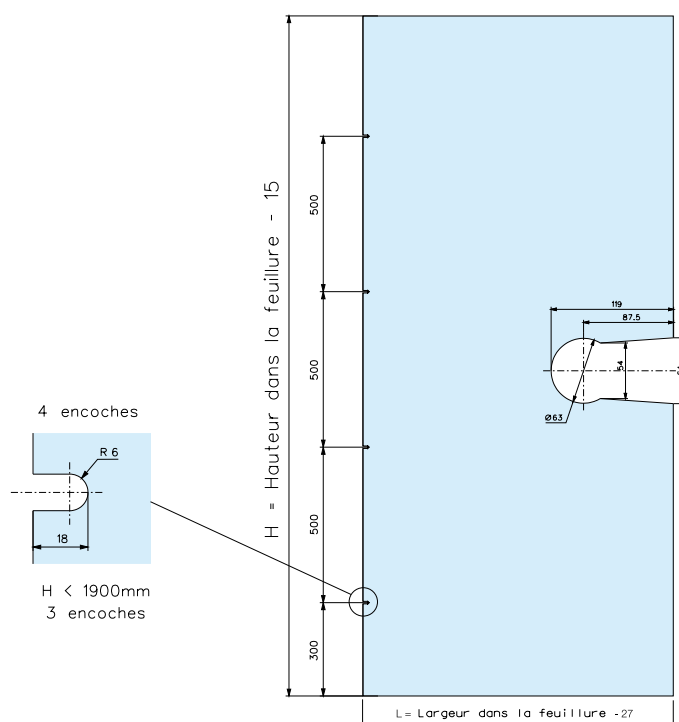

Doorframe

Caractéristiques techniques

- Pour porte en verre trempé de 8, 10 et 12 mm
- Pour panneaux fixe de 8, 10, 12 et 15 mm
- Profil permettant d'appliquer différentes charnières
- Compatible avec les serrures séries LUMIRA, LUMIRA vertical, BASTILLE, LAGUNE
- Le galet de blocage RS02 peut être installé avec une paire de poignées ou une paire de boutons
- Possibilité d'intégration d'une gâche électrique (voir chapitre contrôle d'accès)
- Permet l'intégration facile d'une porte en verre dans un ensemble Sécurit
- Utilisation des profils KL001 et KL002 recommandé pour fixation de l'ensemble

Technical features

- For doors of 8, 10 and 12 mm. thick toughened glass
- For fixed panels of 8, 10, 12 and 15 mm
- Profile allowing several different hinges
- Compatible with lock series LUMIRA, LUMIRA vertical, BASTILLE, LAGUNE
- A blocking roller keep can be installed so handles or door knobs can be used
- Possible installation of an electric release keep (see chapter access control)
- Allows an easy integration of a glass door in a Securit set
- Use KL001 and KL002 profiles recommended to fix the frames

LES + PRODUITS

The + product

Esthétique

Étanchéité
acoustique

Installation facile

Elegant design

Sound proofed

Easy installation

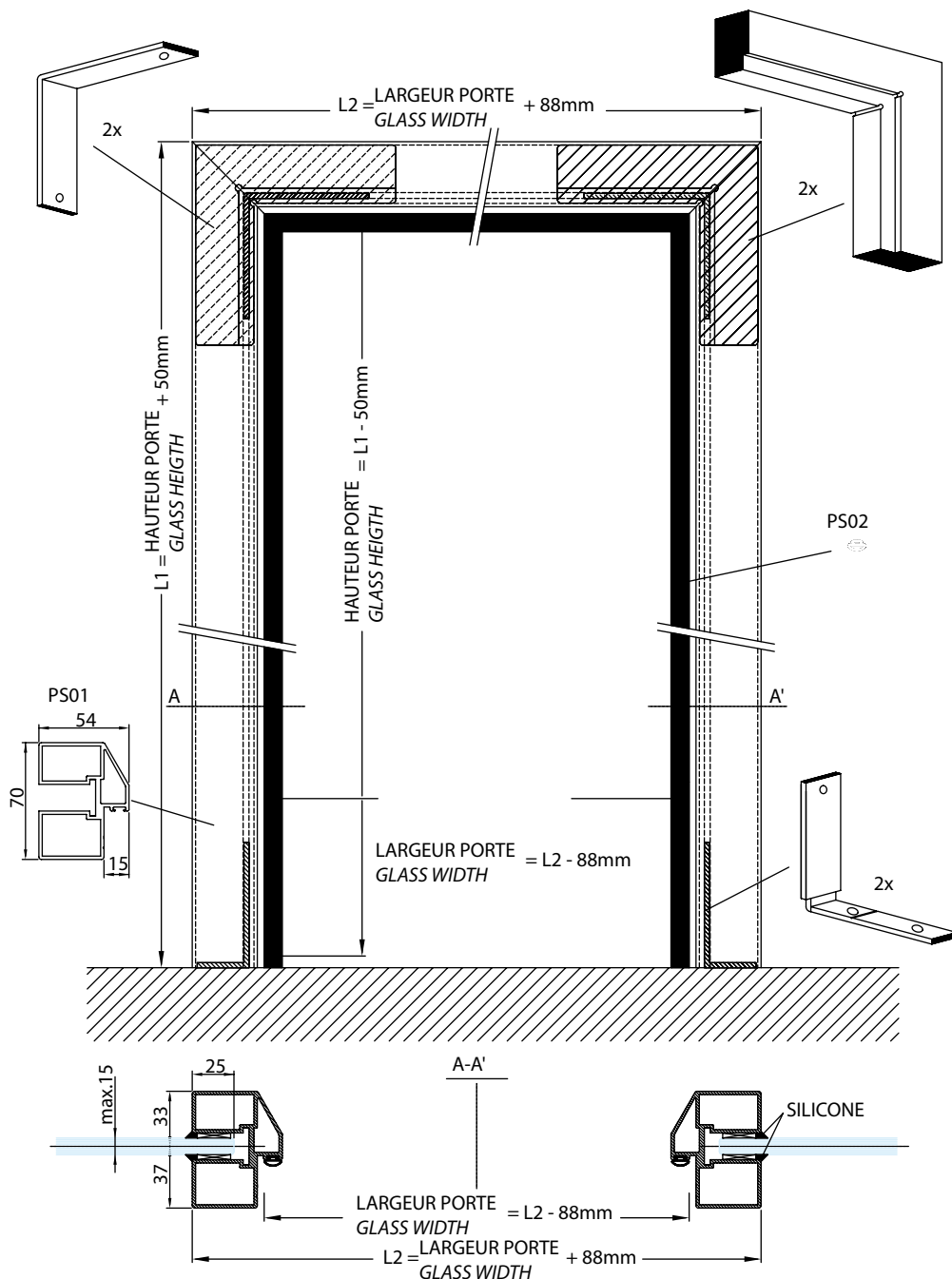



Serrures et
paumelles
Locksets and
hinges

PS01PMR



DIN GAUCHE / DIN LEFT

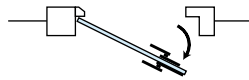

PS01PMR/08L.XX

DIN DROITE / DIN RIGHT



PS01PMR/08R.XX

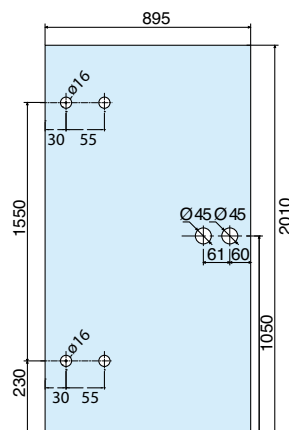

Références / References



Kit complet profil d'encadrement porte en verre de 895 x 2010 mm
avec serrure V525 + V750 et paumelles V504
Complete Kit door frame profile for 895 x 2010 mm glass doors
with lock V525 + V750 and hinges V504

DIN gauche DIN left

DIN droite DIN right



PS01PMR/08L.12 PS01PMR/08L.36

PS01PMR/08R.12 PS01PMR/08R.36

• Largeur de porte adaptée au passage handicapé

• Width of door adapted to disabled people

LES + PRODUITS

The + product

Largeur
de porte adaptée
au passage
handicapé

Width of door
adapted
to disabled
people

PS

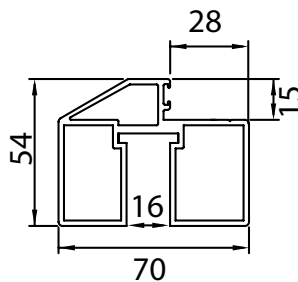

Références / References



Profil d'encadrement vertical longueur 2500 mm
2500 mm length profile for vertical door frame

Profil d'encadrement horizontal longueur 1500 mm
1500 mm length profile for horizontal door frame



PS2500.12 PS2500.36

PS1500.12 PS1500.36

PS02.99



Références / References

Joint pour encadrement porte en verre - le mètre
Rubber strip for door frame - per meter

PS09.99

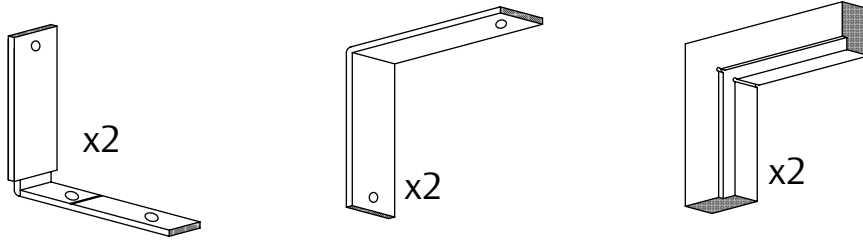

Serrures et
paumelles
Locksets and
hinges

Kit de fixation d'angle pour profil encadrement PS01, vis de fixation inclus
Corner mounting kit for doorframe profil PS01, including fixing screws

V504

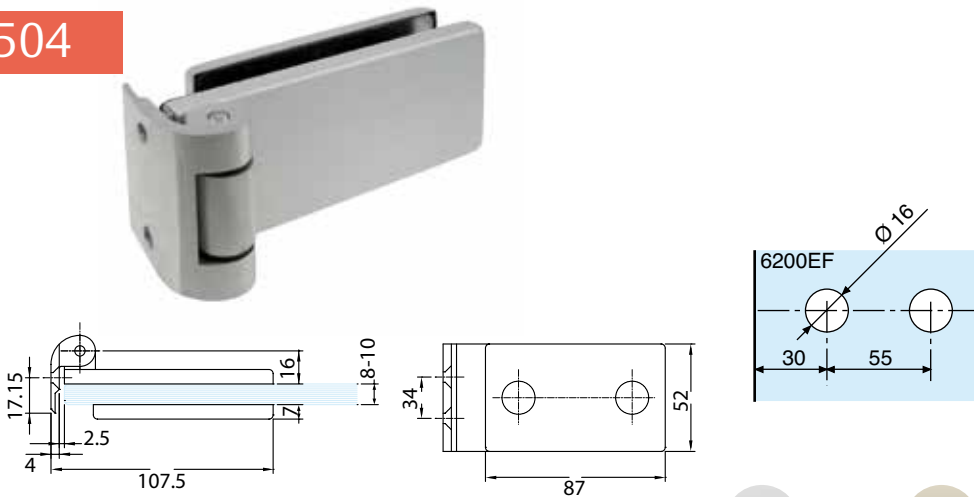

Références / References



Paumelle et fiche pour profil alu encadrement porte en verre PS01
Hinge and multi rebate butt for door frame aluminium profile for glass door PS01

V504.12

V504.36

RS02.99

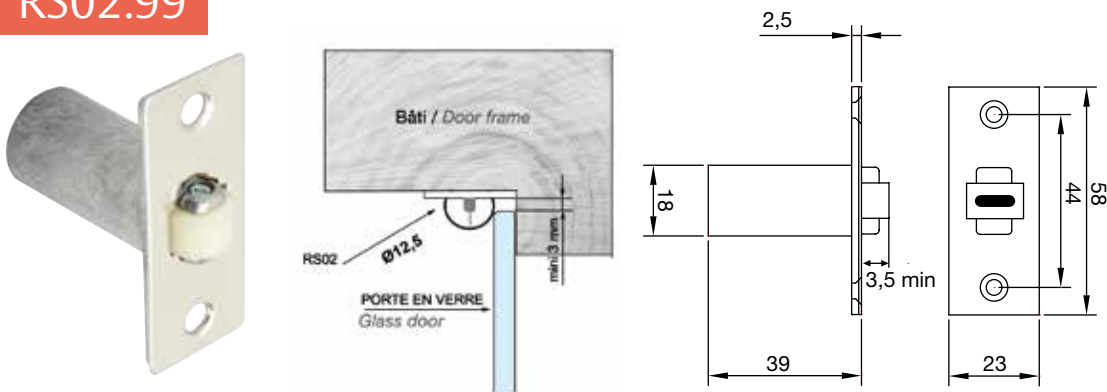

Galet avec rouleau nylon, réglable (3 à 10 mm)
Blocking roller keep, adjustable (3 to 10 mm)

2800.66.4

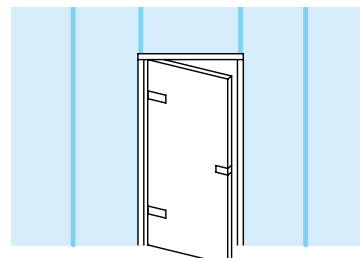
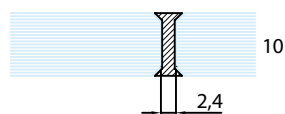
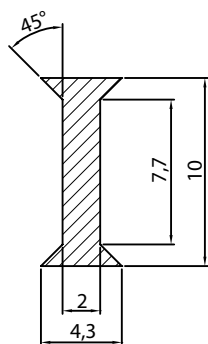

Références / References



Joint PVC pour verre 10 mm adhésif inclus pour joindre 2 panneaux fixes
Dry glazing profile for glass 10 mm including tape for jointing 2 fixed panels

2800.66.4

- Unité de vente : 1 joint conditionné par 10
- Sold in units : packed by 10

2800.66.5

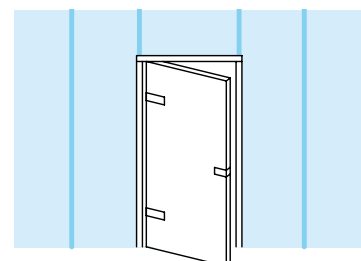
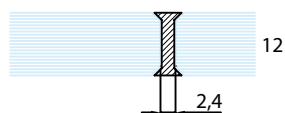
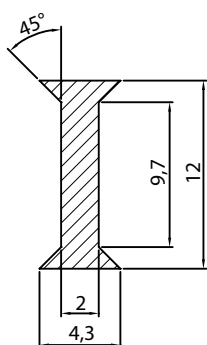

Références / References



Joint PVC pour verre 12 mm adhésif inclus pour joindre 2 panneaux fixes
Dry glazing profile for glass 12 mm including tape for jointing 2 fixed panels

2800.66.5

- Unité de vente : 1 joint conditionné par 10
- Sold in units : packed by 10

LES + PRODUITS

Esthétique
Installation

Attractive design
Easy installation



Paumelles *Hinges*

Lagune & Lumira



Caractéristiques techniques

- Pour verre trempé de 8 à 10 mm
- Montage sur encoche 6200EF
- Dimension maximum des portes 827 mm x 2034 mm
- Poids maximum admissible 45 kg pour 2 paumelles, pour un poids supérieur pose obligatoire d'une 3ème paumelle

Technical features

- For 8 to 10 mm thick toughened glass
- To fit notch 6200EF
- Dimensions size of doors 827 mm x 2034 mm
- Max load 45 kg for 2 hinges, for load exceeding a third hinge must be fitted

LES + PRODUITS

Design des serrures
Lagune et Lumira

*Lagune and Lumira
lock design*



4200

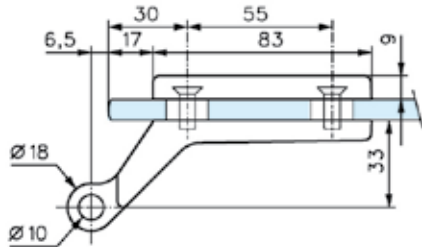
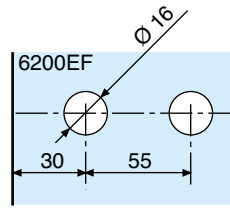

Références / References

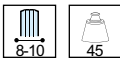

Chromé brillant
Bright chromium



Chromé mat
Matt chromium



Effet inox
Stainless steel effect



Doré
Gold plated



Laqué blanc 9010
Lacquered white RAL 9010

Paumelle pour feuillures de 35 à 40 mm, s'utilise avec les fiches 3204 - 3205 - 3206
Hinge for rebate of 35 to 40 mm, to fit butts 3204 - 3205 - 3206

4200.30.0

4200.31.0

4200.35.0

4200.40.0

4200.51.0

4201

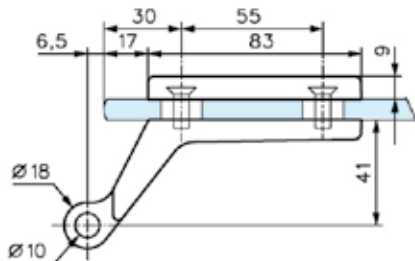
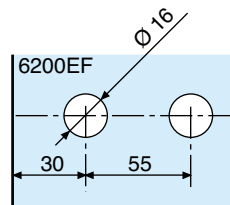

Paumelle pour feuillures supérieures à 40 mm, s'utilise avec les fiches 3204 - 3205 - 3206
Hinge for rebate larger than 40 mm, to fit butts 3204 - 3205 - 3206

Références / References



Chromé brillant
Bright chromium



Chromé mat
Matt chromium



Effet inox
Brushed stainless steel



Doré
Gold plated



Laqué blanc 9010
Lacquered white RAL 9010



4201.30.0

4201.31.0

4201.35.0

4201.40.0

4201.51.0



4201.31.5

Serrures et
paumelles
Locksets and
hinges

4203

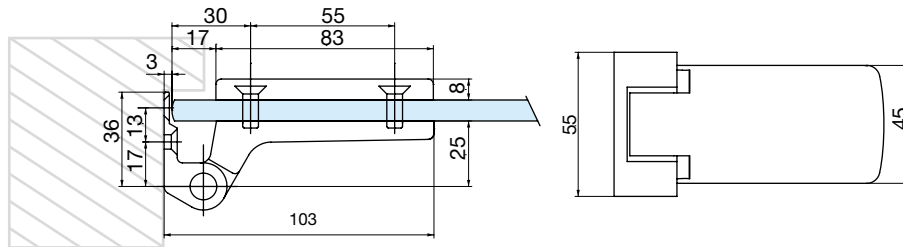
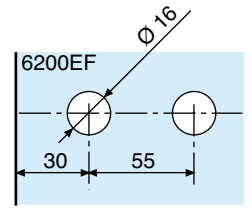

LES + PRODUITS

Montage facile
Tout support

Easy installation
Fits to all kinds
of frame

Références / References

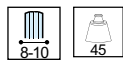

Diamant noir
Black Diamond



Chromé brillant
Bright chromium



Chromé mat
Matt chromium



Effet inox
Stainless steel effect



Doré
Gold plated



Laqué blanc 9010
Lacquered white RAL 9010

Paumelle et fiche multi feuillure
pour tous types d'huisseries
Hinge and multi rebate butt for
all types of frame

4203.23.0

4203.30.0

4203.31.0

4203.35.0

4203.40.0

4203.51.0

V504

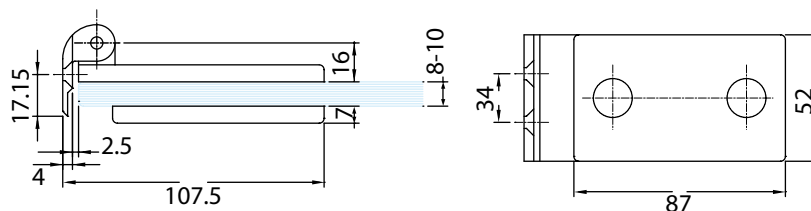
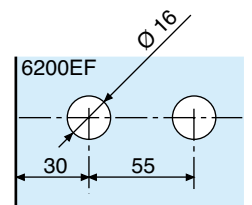

Références / References

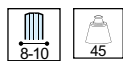

Aluminium anodisé Argent Brossé
Brushed anodised alu silver



Aluminium anodisé Aninox
Brushed anodised alu.

Paumelle et fiche pour profil alu encadrement porte en verre PS01
Hinge and multi rebate butt for door frame profile for glass door PS01

V504.12

V504.36

V505

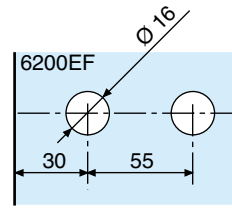

Serrures et paumelles
Locksets and hinges

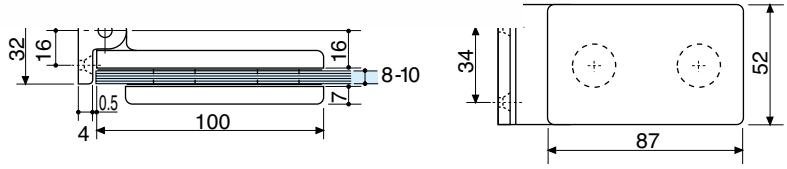

Références / References

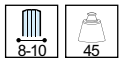

- 
 Laiton poli verni
Polished varnished brass
- 
 Aluminium anodisé Argent Brossé
Brushed anodised alu silver
- 
 Chromé brillant
Bright chromium
- 
 Aluminium anodisé Aninox
Brushed anodised alu.

Paumelle et fiche multi feuillure pour tous types d'huisseries
Hinge and multi rebate butt for all types of frame

- V505.01
- V505.12
- V505.30.0
- V505.36

V507

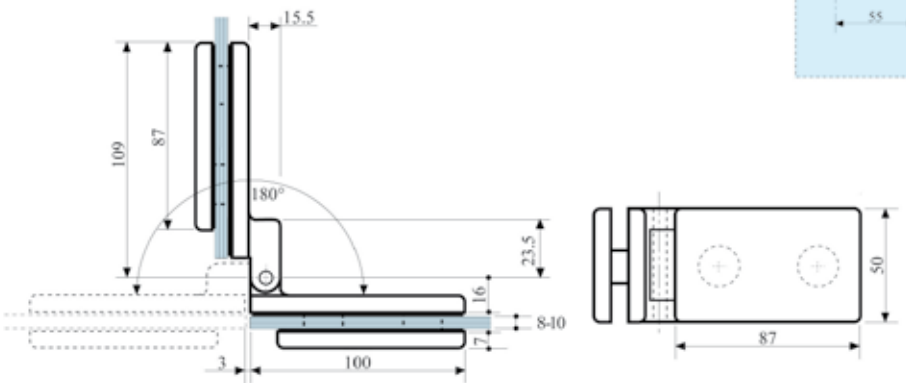
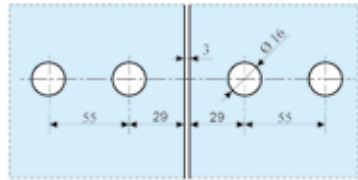

Références / References

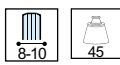

Paumelle double verre/verre pour portes simple action
Glass to glass hinge for single action doors

- 
 Laiton poli verni
Polished varnished brass
- 
 Aluminium anodisé Argent Brossé
Brushed anodised alu silver
- 
 Chromé brillant
Bright chromium
- 
 Aluminium anodisé Aninox
Brushed anodised alu.

- V507.01
- V507.12
- V507.30.0
- V507.36

3204

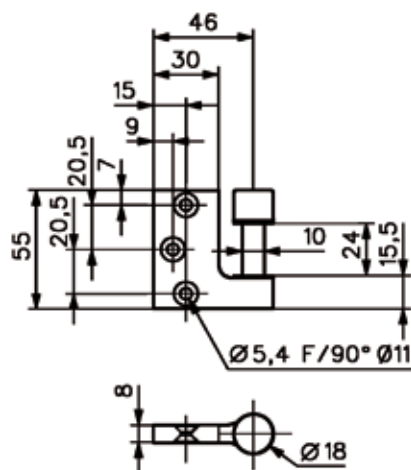

Chromé brillant
Bright chromium



Chromé mat
Matt chromium



Doré
Gold plated



Laqué blanc 9010
Lacquered white RAL 9010

Références / References

Fiche à entailler réversible pour huisseries bois,
s'utilise avec les paumelles 4200 et 4201
Reversible flush fixed butt for wooden door frame,
to fit to hinges 4200 and 4201

3204.30.0

3204.31.0

3204.40.0

3204.51.0

3206.**.0

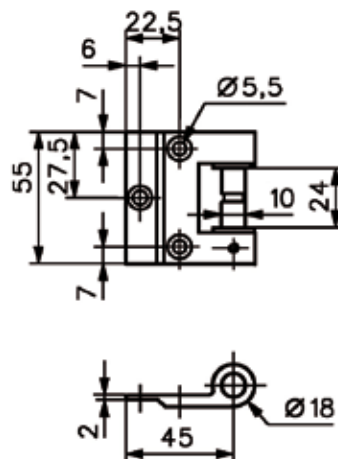

Références / References

Fiche en applique réversible pour toutes huisseries bois, métalliques et aluminium, s'utilise avec les paumelles 4200 et 4201
Reversible surface fixed butt for all types of wooden, metal and aluminium frame, to fit to hinges 4200 and 4201



Laiton poli
Polished brass



Chromé brillant
Bright chromium



Chromé mat
Matt chromium



Effet inox
Stainless steel effect



Doré
Gold plated



Laqué blanc 9010
Lacquered white RAL 9010

3206.00.0

3206.30.0

3206.31.0

3206.35.0

3206.40.0

3206.51.0

3205.**.1

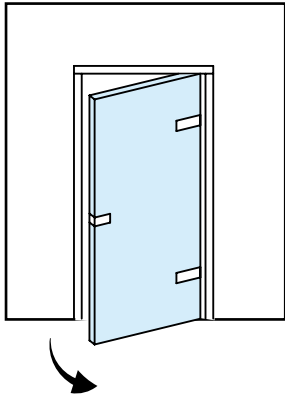
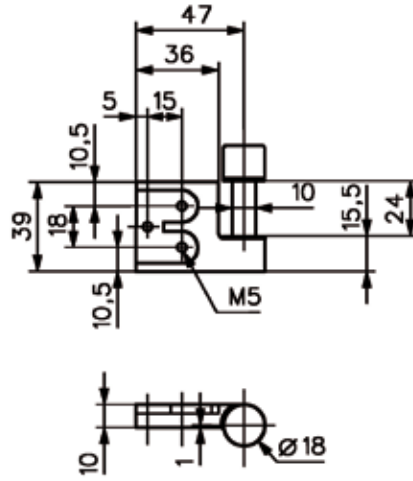

Références / References

Fiche à entailler (main droite) non réversible pour huisseries métalliques, s'utilise avec les paumelles 4200 et 4201

Non reversible mortised butt (right hand) for metal frame, to fit hinges 4200 and 4201

Chromé mat
Matt chromium

3205.31.1

3205.**.2

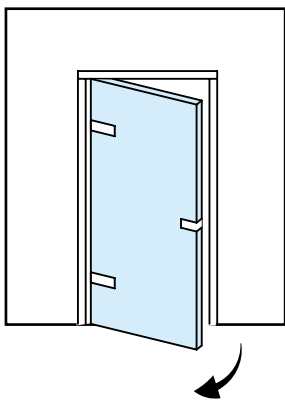
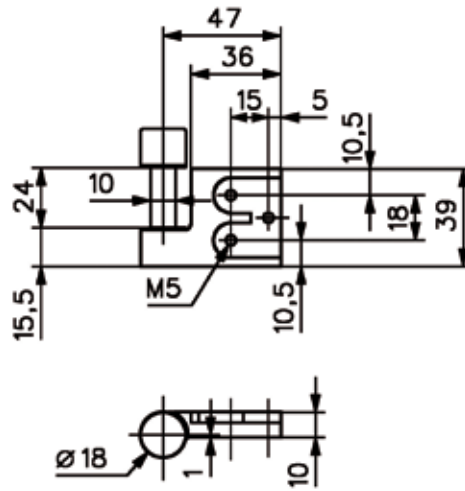

Références / References

Fiche à entailler (main gauche) non réversible pour huisseries métalliques, s'utilise avec les paumelles 4200 et 4201

Non reversible mortised butt (left hand) for metal frame, to fit hinges 4200 and 4201

Chromé mat
Matt chromium

3205.31.2

Paumelles *Hinges*

Bastille



Caractéristiques techniques

- Pour verre trempé de 8, 10 et 12 mm
- Montage sur encoche 6202EX
- Poids maximum admissible 45 kg pour 2 paumelles, largeur maximum 1000 mm, pour un poids supérieur nous consulter

Technical features

- For 8, 10 and 12 mm thick toughened glass
- To fit notch 6202EX
- Max load 45 kg, maximum width 1000 mm, for 2 hinges please consult us for glass weighting more than 45 kg

LES + PRODUITS

Montage facile
Tout support

Easy installation
Fit to all kind of frame

4202

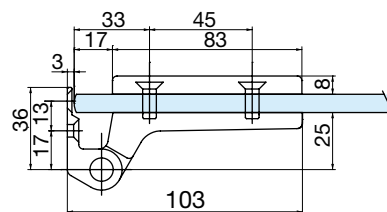
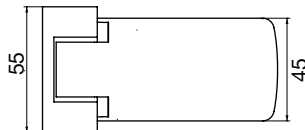
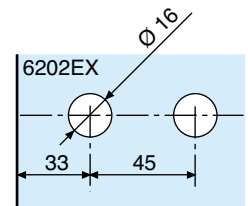

Références / References

Paumelle et fiche multi feuillure pour tous types d'huisseries
Hinge and multi rebate butt for all types of frame



Laiton poli PVD
Polished brass PVD



Chromé brillant
Bright chromium



Chromé mat
Matt chromium



Effet inox
Stainless steel effect



4202.05.0

4202.30.0

4202.31.0

4202.35.0



4202.31.5

4202.35.5

4206

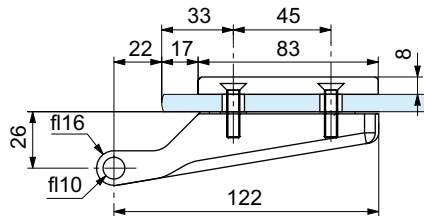
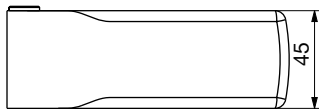
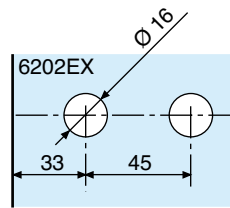

Références / References

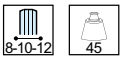

Chromé brillant
Bright chromium



Chromé mat
Matt chromium



Effet inox
Stainless steel effect

4206.30.0

4206.31.0

4206.35.0

Paumelle pour feuillure de 24 mm,
s'utilise avec les fiches 4207 - 4208 - 4209
Hinge for rebate of 24 mm, to fit butts
4207 - 4208 - 4209

V505.2

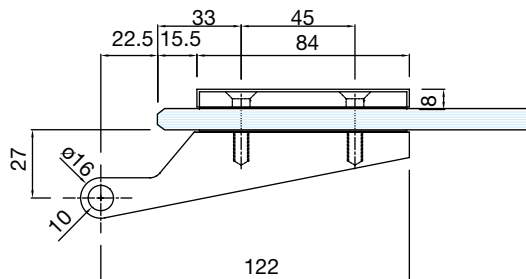
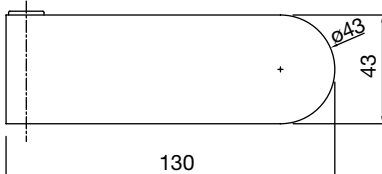
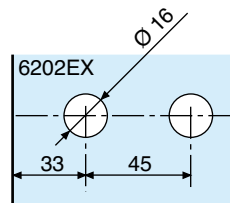

Références / References

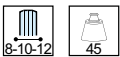

Aluminium anodisé Argent Brossé
Brushed anodised alu silver



Aluminium anodisé Aninox
Brushed anodised alu.

V505.2.12

V505.2.36

Paumelle pour feuillure de 24 mm, s'utilise
avec les fiches 4207 - 4208 - 4209
Hinge for rebate of 24 mm, to fit butts
4207 - 4208 - 4209

4208.99.0

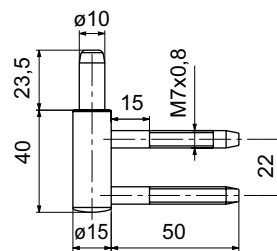

Fiche pour huisseries bois, s'utilise avec la paumelle 4206 et caches fiches 4205
Butt for wooden door frame, to fit hinge 4206 and butt covers 4205



K3172.99

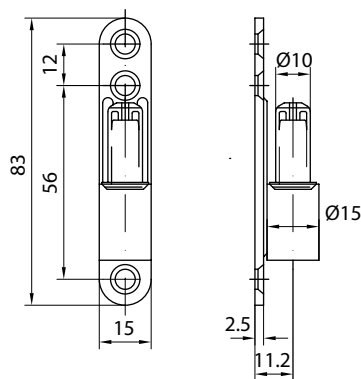

Fiche en applique réversible pour toutes huisseries bois, métalliques et aluminium, s'utilise avec les paumelles 4206 - V505.2 et caches fiches 4205 - V207
Reversible surface fixed butt for all types of wooden, metal and aluminium frame, to fit hinges 4206 - V505.2 and butt covers 4205 - V207

4205

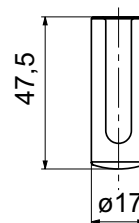

Références / References

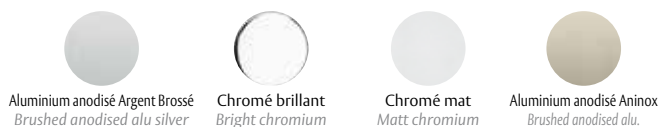

Caches pour fiches 4207 - 4208 - 4209
Covers for butt 4207- 4208 - 4209

4205.12.0

4205.30.0

4205.31.0

4205.36.0

Paumelles *Hinges*

Vertis

Serrures et
paumelles
Locksets and
hinges

V380

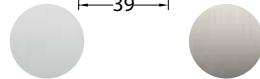
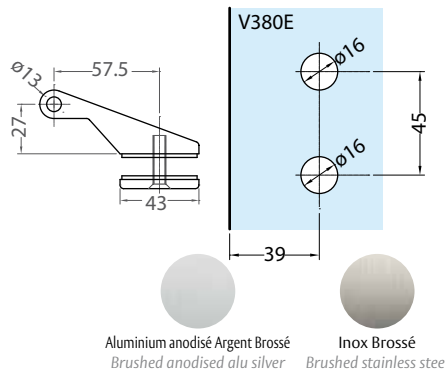
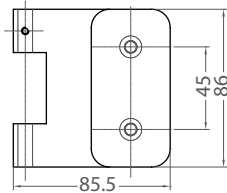

Références / References



Paumelle pour feuillure de 35 mm, s'utilise avec les fiches V206
Hinge for rebate of 35 mm, to fit butts V206

V380.12

V380.15

Aluminium anodisé Argent Brossé
Brushed anodised alu silver

Inox Brossé
Brushed stainless steel

V206.15

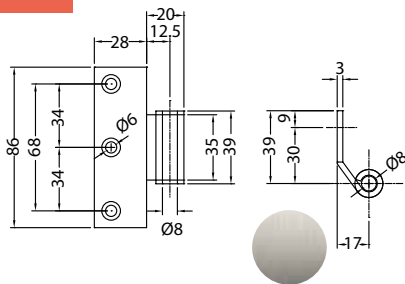

Inox Brossé
Brushed stainless steel

Références / References

Fiche en applique pour paumelle V380
Butt to fit hinge V380

V206.15

V207

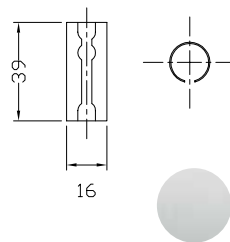

Aluminium anodisé Argent Brossé
Brushed anodised alu silver

Références / References

Cache pour fiches V206
Covers for butt V206

V207.12

V506

Caractéristiques techniques

- Montage sur encoche V506 E
- Poids maximum admissible 55 kg pour 2 paumelles, largeur maximum 900 mm, pour un poids

Technical features

- To fit notch V506 E
- Max load 55 kg, maximum width 900 mm, for 2 hinges please contact us for glass weighing more than 55 kg

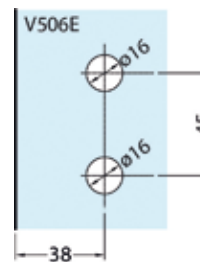
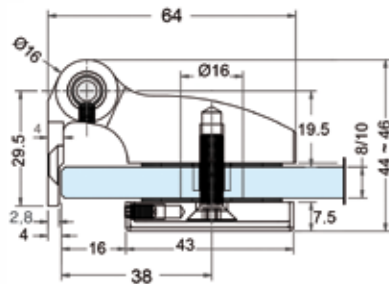
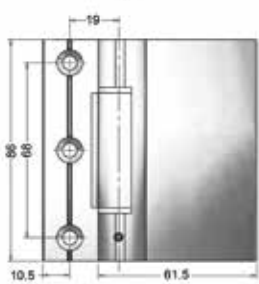

Références / References



Paumelle et fiche multi feuillure pour tous types d'huissieries
Hinge and multi rebate butt for all types of frame

V506.12

V506.36

Aluminium anodisé Argent Brossé
Brushed anodised alu silver

Aluminium anodisé Aninox
Brushed anodised alu.

Freeline

Charnière hydraulique

Hydraulic hinge

Caractéristiques techniques

- Recommandé pour porte intérieure
- Dimensions maxi de la porte 1000 x 3000 mm
- Poids maximum admissible 100 kg pour 2 charnières
- Pour verre trempé de 8, 10 et 12 mm
- Blocage à 90° et retour hydraulique de 80° à 0° dans les 2 sens.
- Réglage possible du point 0 de la porte
- Vitesse de fermeture réglable
- Montage sur encoche 4961E1 pour la charnière simple 4961 et encoche 4962E pour la charnière double 4962
- Livré avec joints et vis de fixation inox

Technical features

- Recommended for inside doors
- Maximum door size 1000 x 3000 mm
- Max. load 100 kg for 2 hinges
- For 8, 10 or 12mm thick toughened glass
- Blocking at 0° and 90° with hydraulic return from 80° to 0° on both sides.
- Adjustable in the closed position
- Adjustable closing speed
- To fit notch 4961E1 for single hinge 4961 and notch 4962E for double hinge 4962
- Supplied with spacers and stainless steel fixing screws

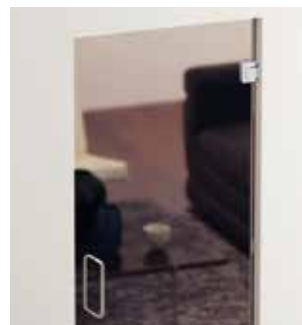

LES + PRODUITS

Système hydraulique pour un confort et une souplesse de fermeture automatique

Solution esthétique

Vitesse de fermeture réglable

Porte 100kg maxi

Installation facile

Hydraulic system for comfort in automatic door closing

Aesthetic solution

Adjustable closing speed

For glass door 100kg

Easy installation

4961.**.0SQ

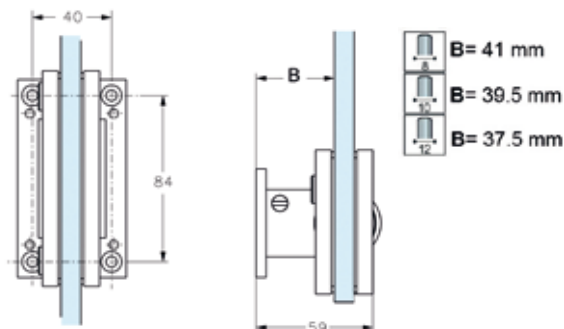
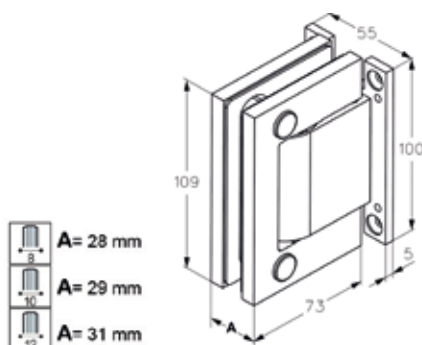
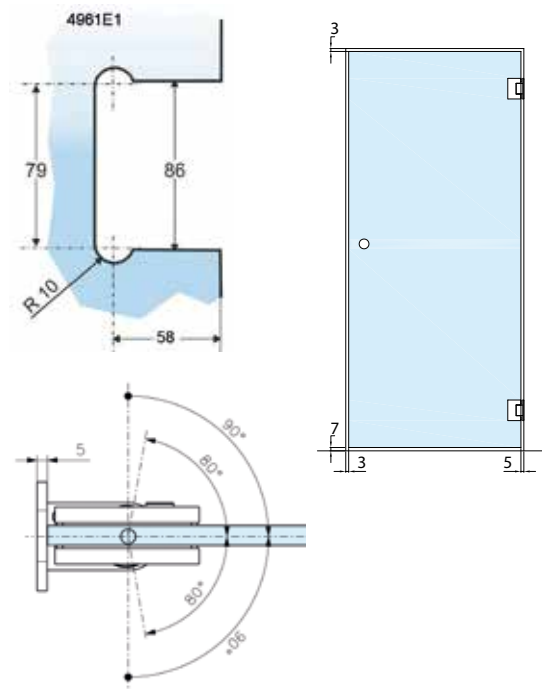

Références / References



Aluminium anodisé Argent Brossé
Brushed anodised alu silver



Chromé brillant
Bright chromium



Aluminium anodisé Aninox
Brushed anodised alu.

Charnière simple hydraulique fixation murale avec 4 trous
Single hydraulic hinge wall plate with 4 fixing holes

4961.12.0SQ

4961.30.0SQ

4961.36.0SQ

4962.**.OSQ

Serrures et
paumelles
Locksets and
hinges

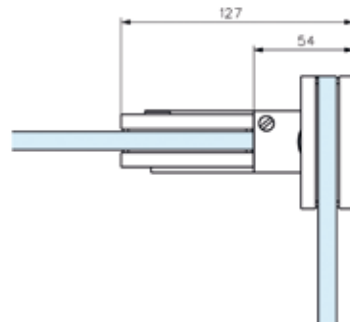
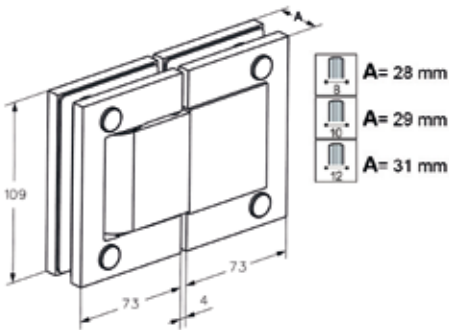
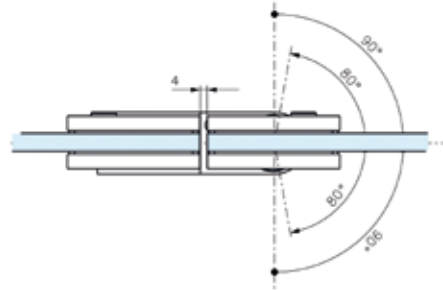
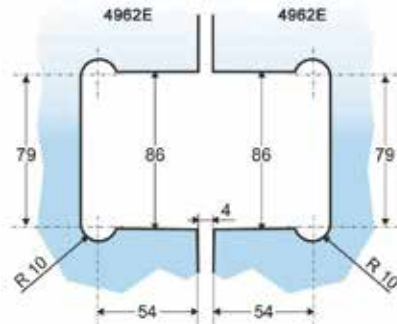
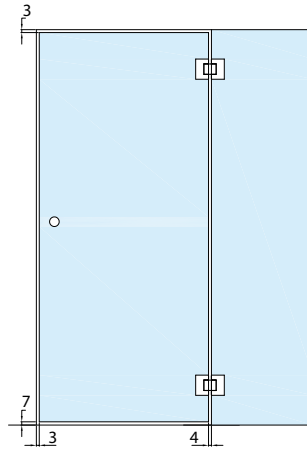

Références / References



Aluminium anodisé Argent Brossé
Brushed anodised alu silver



Chromé brillant
Bright chromium



Aluminium anodisé Aninox
Brushed anodised alu.

Charnière double verre/verre à rappel hydraulique
Glass to glass hydraulic return hinge

4962.12.OSQ

4962.30.OSQ

4962.36.OSQ

Swingo

Caractéristiques techniques

- Blocage à 90°
- Pour verre trempé de 8 et 10 mm
- Poids maximum admissible 60 kg pour 2 charnières
- Largeur maximum de la porte 900 mm
- Montage sur encoche V861E
- Livrée avec joints et vis de fixation
- Réglage possible du point 0 pour le 4861
- Usage bureau et résidentiel non intensif

Technical features

- Blocking points at 90°
- For 8 and 10 mm thick toughened glass
- Max load 60 kg for 2 hinges
- Width of the door 900 mm
- Assembly on notch V861E
- Delivered with spacers and fixing screws

LES + PRODUITS

The + product

Design

Fermeture
automatique
de la porte

Installation facile
et discrète

Elegant design

Automatic door closing

*Easy and discreet
installation*



4861

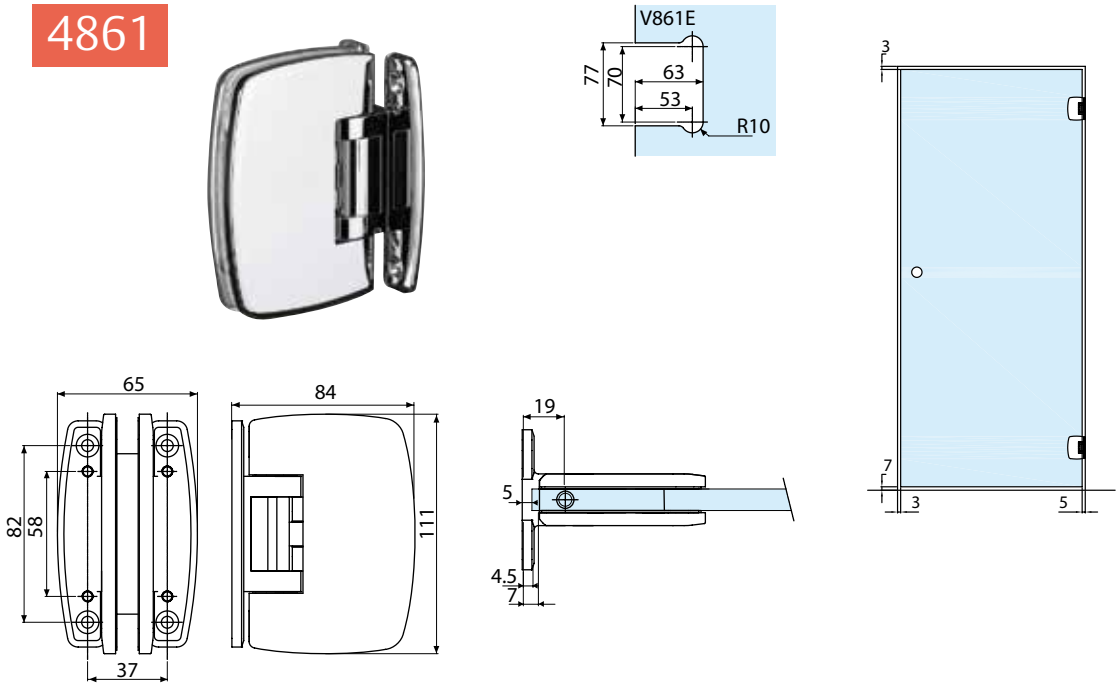

Références / References



Chromé brillant
Bright chromium



Chromé mat
Matt chromium



Effet inox
Stainless steel effect

Charnière simple mur/verre à rappel automatique
Single hinge wall/glass automatic return

4861.30.0

4861.31.0

4861.35.0

4862

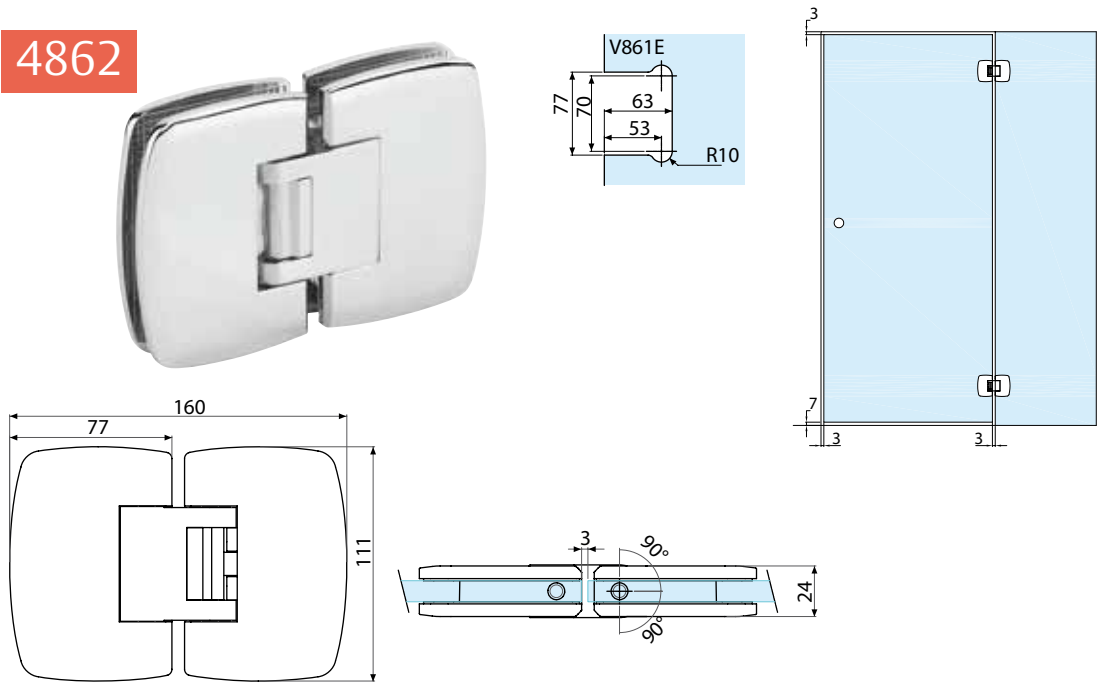

Références / References



Chromé brillant
Bright chromium



Chromé mat
Matt chromium



Effet inox
Stainless steel effect

Charnière double verre/verre à rappel automatique
Glass to glass automatic return hinge

4862.30.0

4862.31.0

4862.35.0

Pentures *Hinges* Lumira

Caractéristiques techniques

- Pour verre trempé épaisseur 8, 10 et 12 mm
- Poids maximum admissible 75 kg
- Dimensions maxi pour portes en verre 900 x 2200 mm
- Montage sur encoche V590E
- Jeu sur la hauteur du sol au plafond H - 14 mm

Technical features

- For 8, 10 and 12 mm thick toughened glass
- Max load 75 kg
- Maximum size for glass doors 900 x 2200 mm
- Assembly on notch V590E
- Allow -14 mm on the height from ground to ceiling H

LES + PRODUITS

The + product

Idéal pour portes
lourdes ou
grand format

*Ideal for heavy and
large doors*

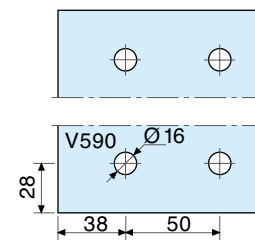
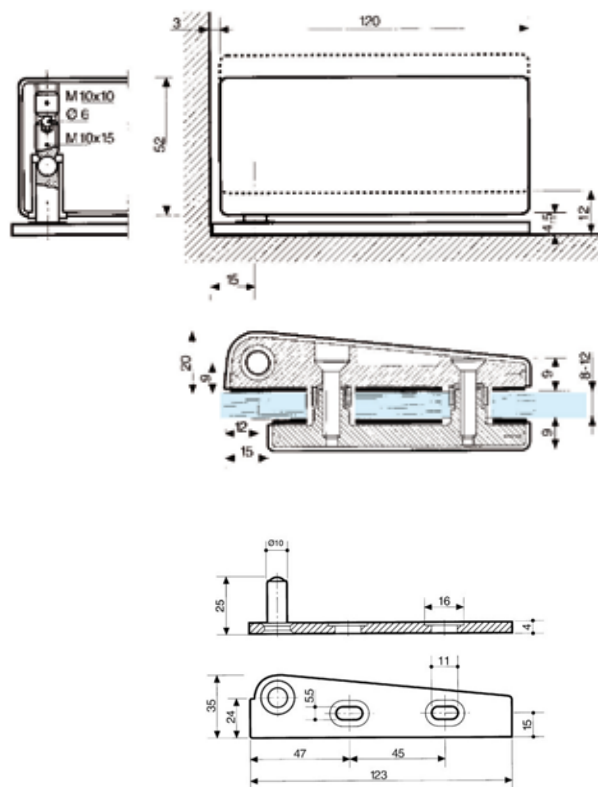

JEUX RECOMMANDÉS RECOMMENDED TOLERANCES

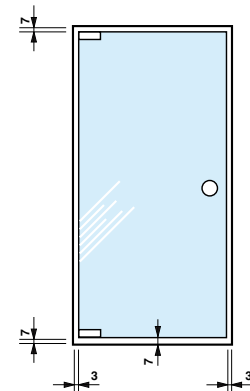

V590

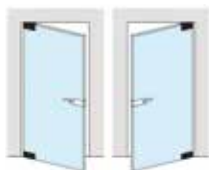
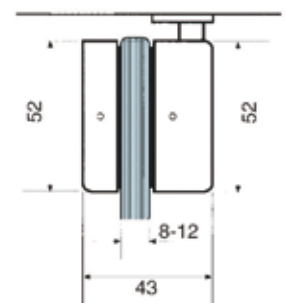

Références / References



Aluminium anodisé Argent Brossé
Brushed anodised alu silver

Aluminium anodisé Aninox
Brushed anodised alu.

V590.12

V590.36

Pentures déportées basse et
haute avec platines

*Top and bottom offset pivot
hinges with mounting plate*

Loqueteaux

Serrures et
paumelles
Locksets and
hinges

Caractéristiques techniques

- Ne nécessite aucune encoche
- Se pose sur le chant du verre, jeu minimum 4 mm
- Blocage du pêne en position sortie ou rentrée
- Pour verre trempé de 8, 10 et 12 mm
- Livrée avec gâche plate (2 clés pour réf 1448)

Technical features

- Requires no notch
- Fixing on edge of door, minimum space 4 mm
- Bolt can be blocked in the projecting or retracted position
- For 8, 10 and 12 mm thick toughened glass
- Supplied with flat keep (2 keys for ref 1448)

1445

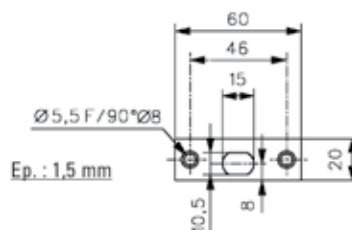
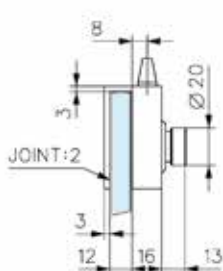
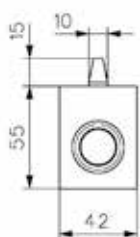

Références / References



Loqueteau à bouton
Clip on lock with notch



Laiton poli
Polished brass



Chromé brillant
Bright chromium



Chromé mat
Matt chromium

1445.00.0

1445.30.0

1445.31.0

1446

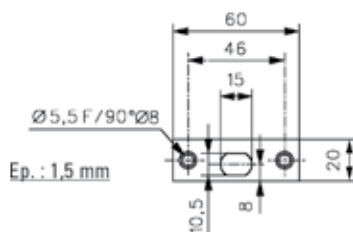
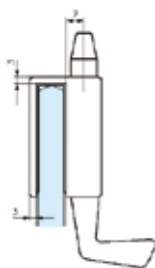
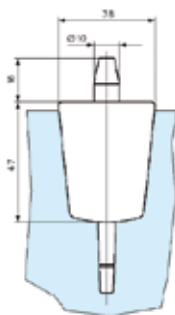

Références / References

Loqueteau à tirage
Clip on lock with
pull catch



Laiton poli PVD
Polished brass PVD



Chromé brillant
Bright chromium



Chromé mat
Matt chromium



Effet inox
Stainless steel effect



Laqué Blanc
Lacquered white RAL 9010

1446.05.0

1446.30.0

1446.31.0

1446.35.0

1446.51.0



1446.30.5

1446.31.5

Loqueteaux
Clip-on locks

1448

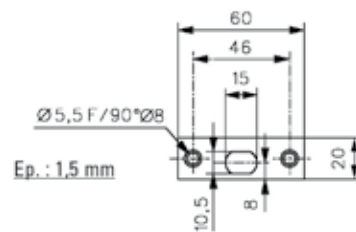
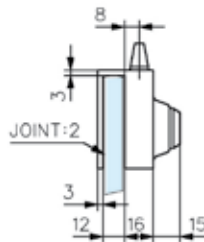
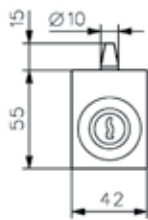

Références / References



Loqueteau à clé
Clip on lock with cylinder



Laiton poli
Polished brass

1448.00.0



Chromé brillant
Bright chromium

1448.30.0



Chromé mat
Matt chromium

1448.31.0

LES + PRODUITS
The + product

Idéal pour portes
semi-fixe

Idéal for semi-fixed
doors

1447

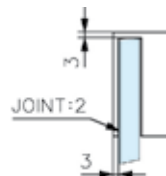

Références / References



Boîtier gâche pour loqueteaux série 1445/1448
Matching patch keep for clip on lock series 1445/1448



Laiton poli
Polished brass

1447.00.0



Chromé brillant
Bright chromium

1447.30.0



Chromé mat
Matt chromium

1447.31.0

1449

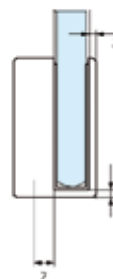

Références / References



Boîtier gâche pour
loqueteaux série 1446
Matching patch keep for
clip on lock series 1446



Chromé brillant
Bright chromium

1449.30.0



Chromé mat
Matt chromium

1449.31.0



Pentures, serrures
et pièces de fixation
Locks and patch fittings

ASSA ABLOY

Pentures,
serrures et
pièces de fixation
*Locks and
patch fittings*

Pentures 101

Caractéristiques techniques

- Pour verre trempé de 10 mm
- Montage sur encoche 101
- Poids de porte maximum 50 kg
- Dimensions maxi des portes 900 x 2200 mm
- Réversible droite, gauche, haute ou basse pour les séries 3271 et 3275
- Réversible droite, gauche pour les séries 3272 et 3273
- Livré avec joints épaisseur 1 mm
- Pentures basses compatible avec :
 - Pivot frein de sol hydraulique
 - Crapaudine

Technical features

- For 10 mm thick toughened glass
- Assembly on notch 101
- Maximum door weight 50 kg
- Dimensions size of the doors 900 x 2200 mm
- Top or bottom hinge reversible left or right for series 3271 and 3275
- Left or right hinge reversible for series 3271 and 3275
- Supplied with spacers of 1 mm thick
- Bottom hinge compatible with :
 - Hydraulic floor sprin
 - Pivot



LES + PRODUITS

The + product

Réversible
droite, gauche,
haute ou basse
pour 3271 / 3275

Top or bottom hinge
reversible left or right
for 3271 and 3275

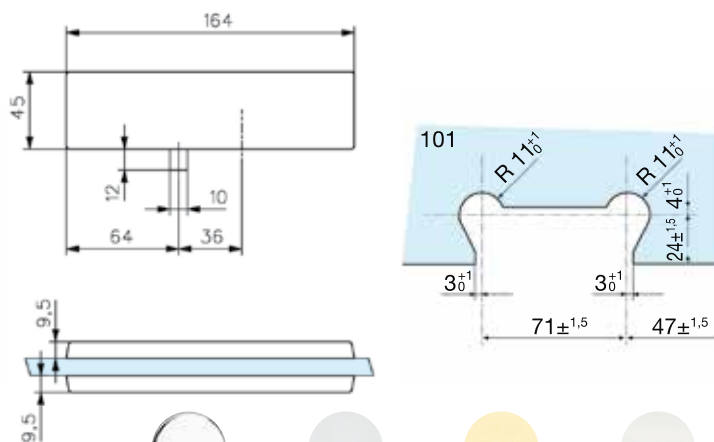

Références / References

3271



Chromé brillant
Bright chromium

Chromé mat
Matt chromium

Doré
Gold plated

Laqué blanc 9010
Lacquered white RAL 9010

Penture réversible haute, basse à enjoliveurs pour axe carré français
Top and bottom reversible patch hinge with cover plate, French square recess

3271.30.0

3271.31.0

3271.40.0

3271.51.0

3272

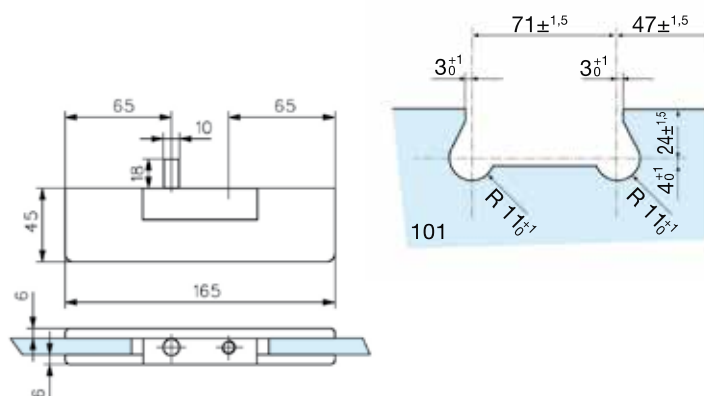

Références / References



Laiton poli
Polished brass



Chromé brillant
Bright chromium



Chromé mat
Matt chromium

Penture massive haute
Solid top patch hinge

3272.00.0

3272.30.0

3272.31.0

3273

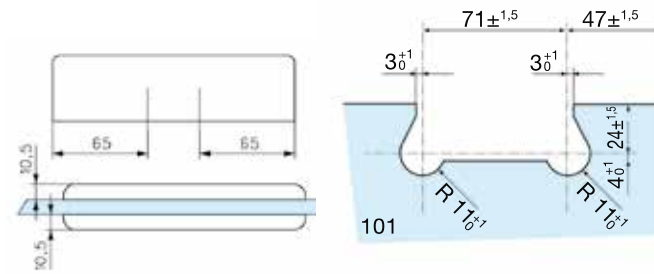

Pentures,
serrures et
pièces de fixation
*Locks and
patch fittings*

Références / References



Laiton poli
Polished brass



Chromé brillant
Bright chromium



Chromé mat
Matt chromium

Penture massive basse pour axe carré français
Solid bottom patch hinge with French square recess

3273.00.0

3273.30.0

3273.31.0

3280

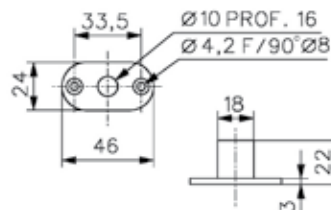

Laiton poli
Polished brass



Chromé brillant
Bright chromium



Chromé mat
Matt chromium

Références / References

Boîte à roulement pour pentures séries 3271, 3272
Bearing box for patch hinges series 3271, 3272

3280.00.0

3280.30.0

3280.31.0

3281

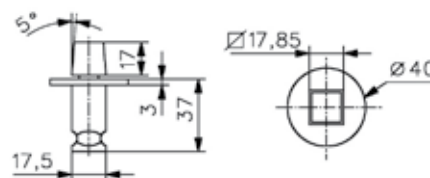

Laiton poli
Polished brass



Chromé brillant
Bright chromium



Chromé mat
Matt chromium

Références / References



Crapaudine à axe carré pour pentures séries 3271 et 3273
Square pin step bearing for patch hinges series 3271 and 3273

3281.00.0

3281.30.0

3281.31.0

Serrures basses , boîtier gâche et gâche séries 1358

*Bottom lock, matching patch keep
and keep with guard series 1358*



Caractéristiques techniques

- Pour verre trempé de 10 mm
- Montage sur encoche 61
- Pêne monobloc avec bague anti-sciage
- A cylindre profil européen panneton DIN (norme DIN 18254)
- Livré avec 1 gâche plate et 3 clés

Technical features

- For 10 mm thick toughened glass
- Assembly on notch 61
- One piece bolt with hardened insert
- European profile cylinder (DIN 18254)
- Supplied with flat keep and 3 keys

1358

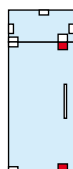
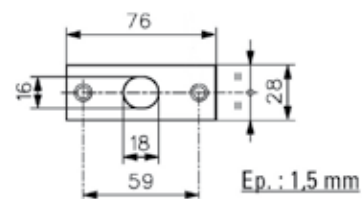
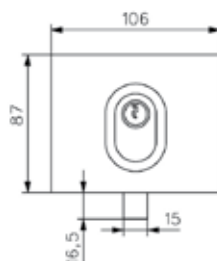
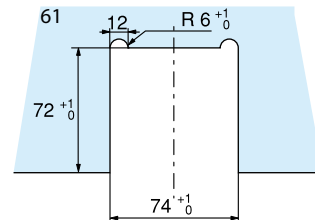
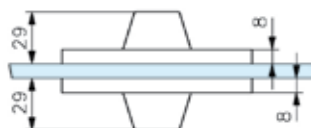

Références / References



Serrure basse avec cylindre à 2 entrées de clé
Bottom lock with euro profile cylinder with 2 key entries



Laiton poli
Polished brass

1358.00.0



Chromé brillant
Bright chromium

1358.30.0



Chromé mat
Matt chromium

1358.31.0

1353

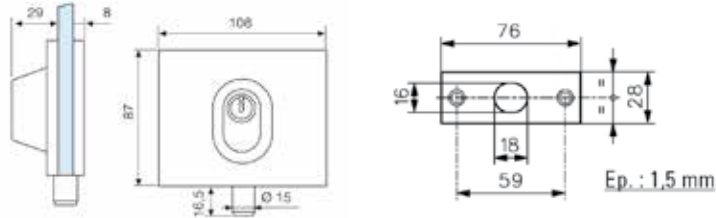
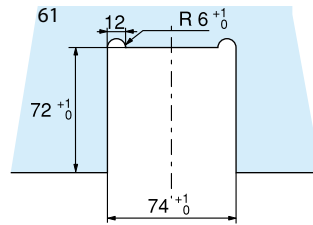

Pentures,
serrures et
pièces de fixation
*Locks and
patch fittings*

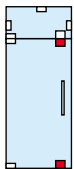

Références / References



Serrure basse à une entrée de clé
Bottom lock with key on one side



Chromé brillant
Bright chromium

1353.30.0



Chromé mat
Matt chromium

1353.31.0

1359

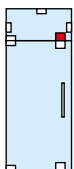
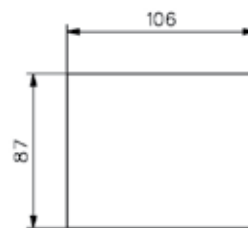
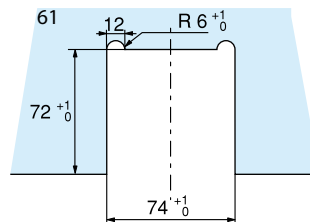

Références / References



Boîtier gâche pour serrures 1352, 1353, 1357 et 1358
Matching patch keep for lock 1352, 1353, 1357 and 1358



Chromé brillant
Bright chromium

1359.30.0



Chromé mat
Matt chromium

1359.31.0

Verrou cavalier à demi-cylindre 1435

Clip on lock with half euro profile cylinder 1435

Caractéristiques techniques

- Montage sans encoche
- Se pose en cavalier sur la porte, jeu minimum 4 mm
- Fixation par 2 vis de serrage pour 1435 et 1439
- Permet d'obtenir un 2ème point de condamnation avec une serrure basse série 1358
- Possibilités de combinaison avec passe général sauf 1436
- Livré avec 1 gâche plate et 3 clés

Technical features

- No notches required
- Fixing on edge of door, minimum space 4 mm
- Fixing with 2 screws for series 1435 and 1439
- To match bottom lock series 1358 to provide 2 locking points
- Possibility of combinations with master key except 1436
- Supplied with flat keep and 3 keys



1435

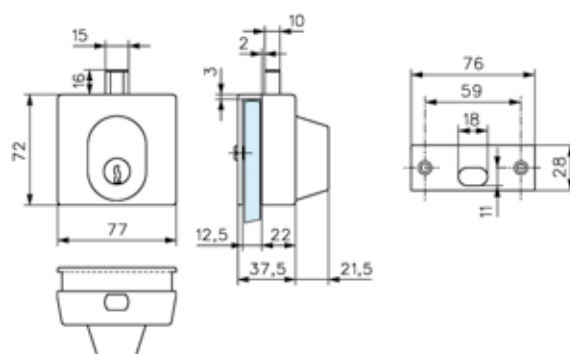

Références / References



Chromé brillant
Bright chromium



Chromé mat
Matt chromium

Verrou cavalier à demi-cylindre profil européen panneton DIN
Clip on lock with half euro profile cylinder

1435.30.0

1435.31.0

1439

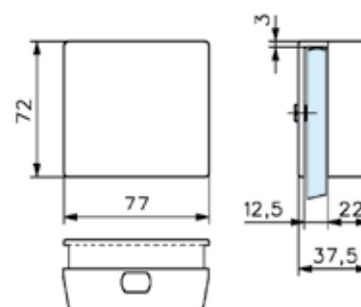

Références / References



Chromé brillant
Bright chromium



Chromé mat
Matt chromium

Boîtier gâche pour verrou cavalier 1435
Matching patch keep to fit with series 1435

1439.30.0

1439.31.0



S171..3**



Laiton poli
Polished brass



Inox Brossé
Brushed stainless steel



Inox poli
Polished stainless steel

100 vis pour pentures séries 3272 et 3273
100 screws for patch hinge series 3272 and 3273

S171.00.3

S171.15.3

S171.16.3

S229.99.4



100 joints épaisseur 1mm pour pentures séries 3272 et 3273
100 spacers 1 mm thickness for patch hinge series 3272 and 3273

S229.99.6



100 joints épaisseur 1,5 mm pour pentures séries 3271
100 spacers 1,5 mm thickness for patch hinge series 3271

Pentures,
serrures et
pièces de fixation
*Locks and
patch fittings*

Cilindric®

Caractéristiques techniques

- Dimensions \varnothing 55 mm hauteur 75 mm
- Inox AISI 304
- Pour verre de 8, 10 et 12 mm
- Montage sur encoche
- Poids maximum 100 kg

Technical features

- Dimensions \varnothing 55 mm height 75 mm
- Stainless steel 304
- For 8, 10 and 12 mm thick glass
- Assembly on notch
- Maximum door weight 100 kg



LES + PRODUITS

The + product

Design High Tech

Grande qualité
de finition

Résistance

Modularité

Inox massif

High tech design

High quality finishes

Resistance

Modularity

Solid stainless Steel

C500D

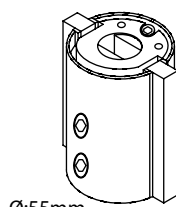

\varnothing :55mm
height:75mm

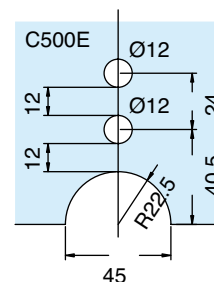

Références / References



Penture basse empreinte pour axe allemand
Bottom patch fitting German insert



Inox Brossé
Brushed stainless steel

C500D.15

C500I

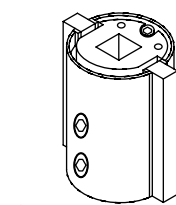

\varnothing :55mm
height:75mm

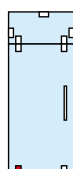
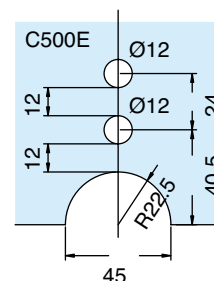

Références / References



Penture basse empreinte pour insert italien
Bottom patch fitting Italian insert



Inox Brossé
Brushed stainless steel

C500I.15

C501

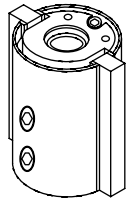

Ø:55mm
height:75mm

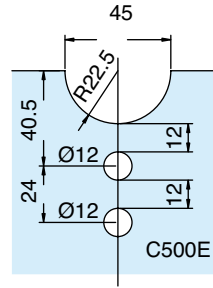

C500E



Inox Brossé
Brushed stainless steel

Références / References



Penture haute
Top patch fitting

C501.15

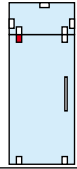

C502

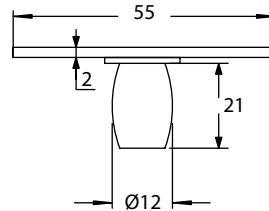

Inox Brossé
Brushed stainless steel

Références / References

Pivot haut, fixation linteau ou plafond
Top pivot, fixing lintel or ceiling

C502.15

C511

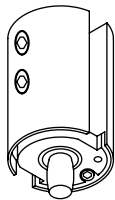

Ø:55mm
height:75mm

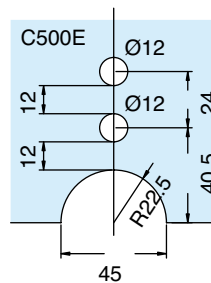

C500E



Inox Brossé
Brushed stainless steel

Références / References



Contre-sabot d'imposte avec pivot
Transom panel patch with pivot

C511.15

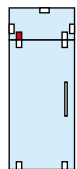

Pentures,
serrures et
pièces de fixation
Locks and
patch fittings

AC299.33

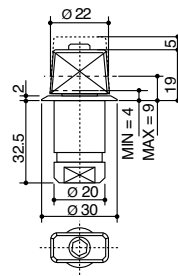

Crapaudine à sceller réglable axe rectangulaire allemand
Adjustable German rectangular floor pivot, to be embedded

AC246.33

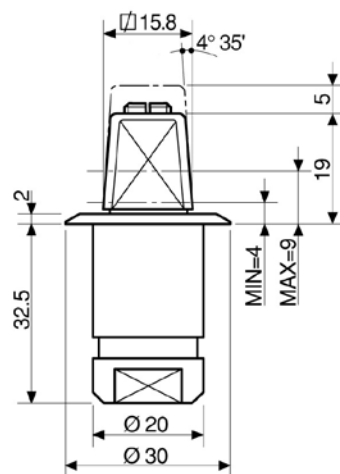

Crapaudine à sceller réglable axe carré italien
Adjustable Italian square floor pivot, to be embedded

V502

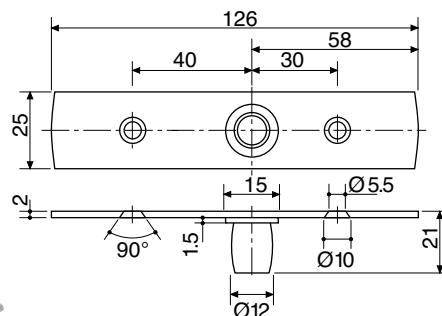

Références / References

Pivot supérieur pour C501
Offset top pivot for C501

Inox Brossé
Stainless steel effect

V502.15

C528A

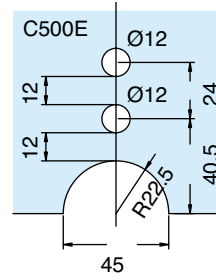
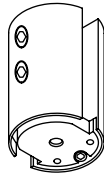

Inox Brossé
Brushed stainless steel

Références / References



Pièce de fixation pour panneaux fixe
Wall to glass patch for transom or fixed panel

C528A.15

C528B

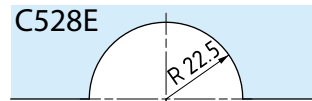
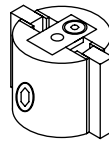

Inox Brossé
Brushed stainless steel

Références / References



Cilindric pièce de fixation pour panneaux fixe hauteur 35 mm
Cilindric wall to glass patch for transom or fixed panel height 35mm

C528B.15

C581

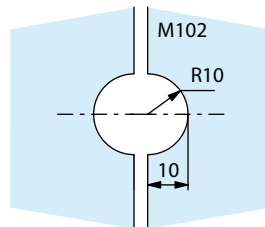
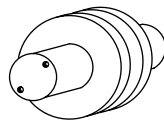

Inox Brossé
Brushed stainless steel

Références / References



Pièce de liaison pour 2 glaces fixes modèle rond / simple
Connector for 2 fixed panels single rounded model

C581.15

C582

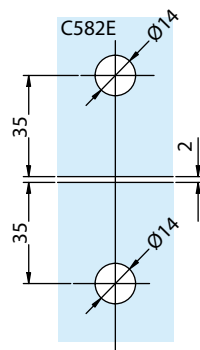
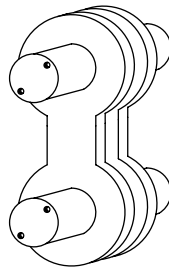

Inox Brossé
Brushed stainless steel

Références / References



Pièce de liaison pour 2 glaces fixes modèle '8'
Connector for 2 fixed panels '8' shape

C582.15

C222L

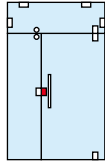
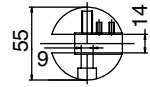
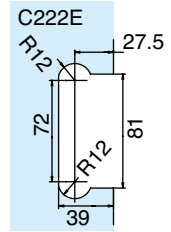
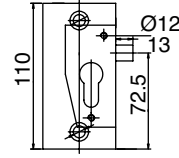
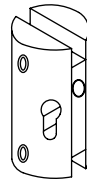

Références / References



Serrure bord de verre gauche extérieur, sans cylindre et sans gâche
Lock on left outside edge of glass, supplied without cylinder and flat keep



Inox Brossé
Brushed stainless steel

C222L.15

C222R

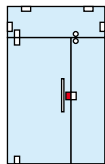
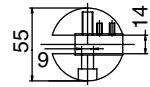
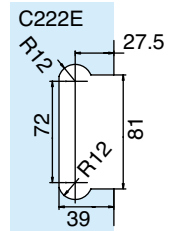
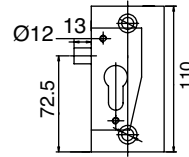
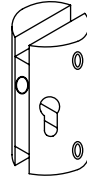

Références / References



Serrure bord de verre droite extérieur, sans cylindre et sans gâche
Lock on right outside edge of glass, supplied without cylinder and flat keep



Inox Brossé
Brushed stainless steel

C222R.15

C223L

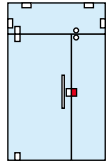
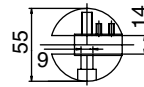
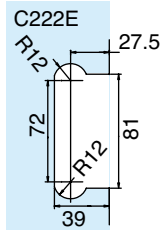
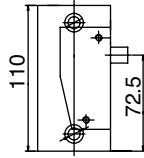
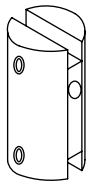

Références / References



Contre-boîtier pour serrure, bord de verre gauche extérieur
Pacth keep on left side edge of fixed panel



Inox Brossé
 Brushed stainless steel

C223L.15

Pentures,
 serrures et
 pièces de fixation
*Locks and
 patch fittings*

C223R

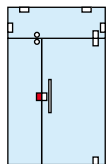
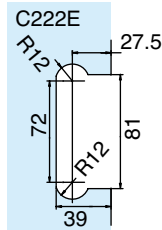
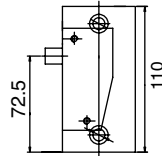
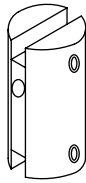

Références / References



Contre-boîtier pour serrure, bord de verre droit extérieur
Pacth keep on right side edge of fixed panel



Inox Brossé
 Brushed stainless steel

C223R.15

C529

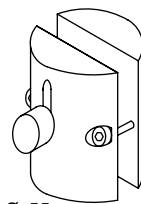

Ø :55mm
 height: 75mm

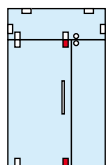
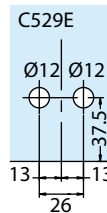

Références / References



Serrure à pieds sans gâche
Foot operated lock without flat keep



Inox Brossé
 Brushed stainless steel

C529.15

Poignées
Handles

C600PG22

C600PG30

C601PG22

C601PG30

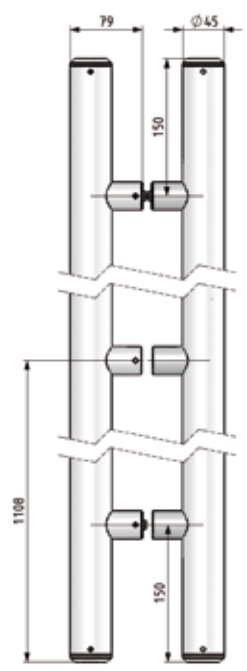
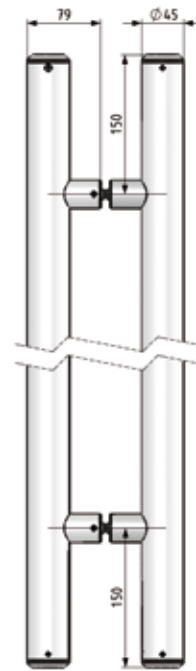
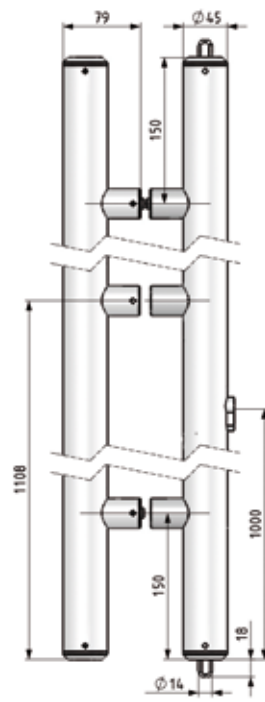
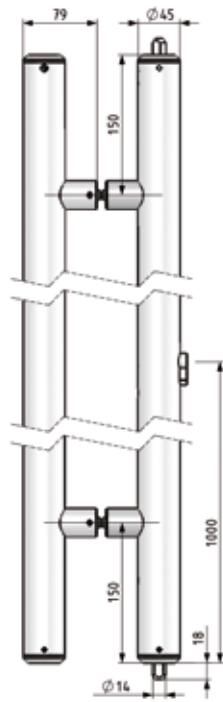

Références / References



Inox Brossé
Brushed stainless steel

Poignées Ø 45 mm, avec serrure 2 points d'un côté, hauteur maxi : 2200 mm
Handle 45 Ø mm with 2 point lock on one side, height max : 2200 mm

C600PG22.15

Poignées Ø 45 mm, avec serrure 2 points d'un côté, hauteur entre 2200 mm et 3000 mm maxi
Handle 45 Ø mm with 2 point lock on one side, height max between 2200 mm and 3000 mm

C600PG30.15

Poignées Ø 45 mm, hauteur maxi : 2200 mm
Handle 45 Ø mm height max 2200 mm

C601PG22.15

Poignées Ø 45 mm, hauteur entre 2200 mm et 3000 mm maxi
Handle 45 Ø mm, height max between 2200 mm and 3000 mm

C601PG30.15

LES + PRODUITS
The + product

Esthétique
Double fonction :
tirage et verrouillage

Robustesse

Porte grande
hauteur

Attractive design

Double fonction :
pull and lock

Resistant

For high doors



C532



Inox Brossé
Brushed stainless steel

Références / References

Gâche pour poignée C600
Keep plate for C600

C532.15

C541

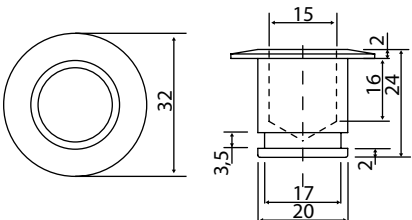

Inox Brossé
Brushed stainless steel

Références / References

Gâche tubulaire pour pêne bas des C600-C517-C529
Tubular keep bottom bolt for C600-C517-C529

C541.15

C603PG

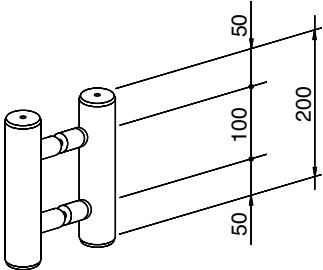

Inox Brossé
Brushed stainless steel

Références / References



Contre-boîtier d'imposte pour C600
Transom patch keep for C600

C603PG.15

Pentures,
serrures et
pièces de fixation
*Patch fittings
and locks*

PF Patch fittings

Caractéristiques techniques

- Pour verre trempé épaisseur 10 et 12 mm
- Poids maximum 100 kg
- Dimensions maxi. des portes 1100 x 2400 mm

Technical features

- For 10 and 12 mm thick toughened glass
- Maximum Door Weight 100 kg
- Maximum Door Width 1100 x 2400 mm



LES + PRODUITS

The + product

Grande qualité
de finition

Gamme complète

Réversibles

High quality finishes

Full range

Reversible

Installation standard

Standard installation

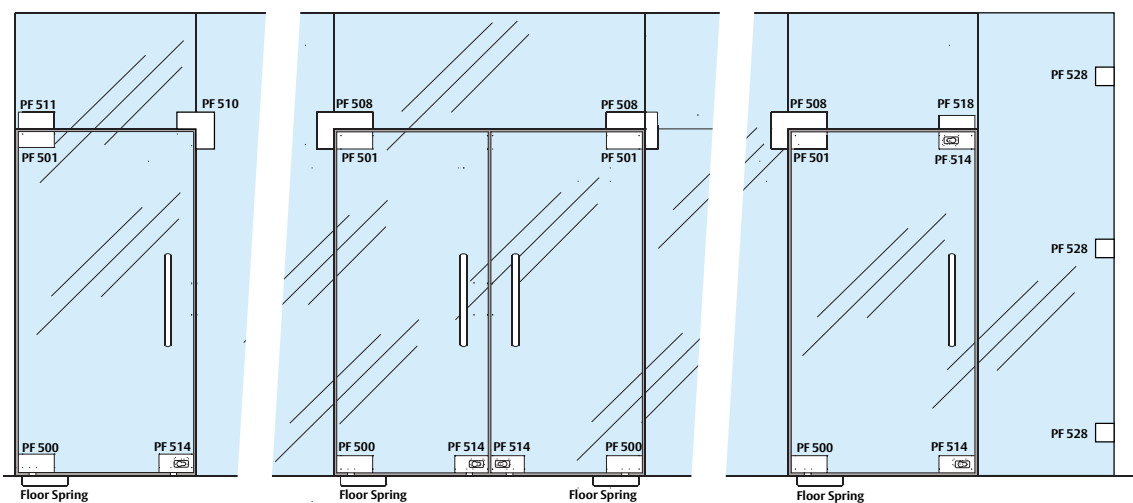
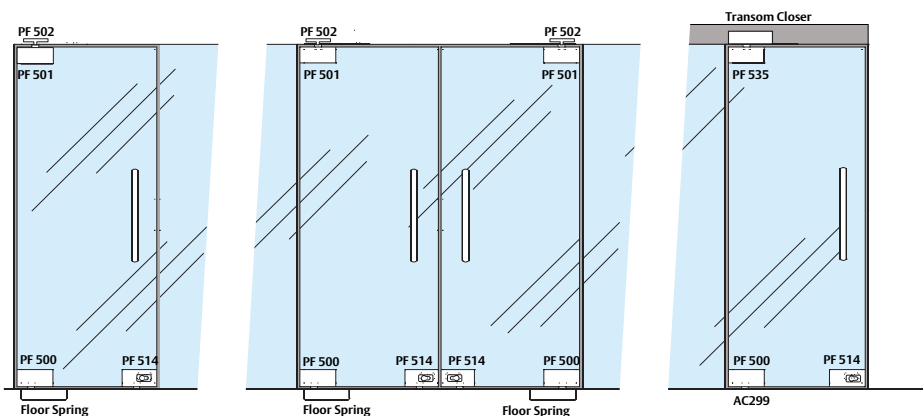

JEUX RECOMMANDÉS

RECOMMENDED TOLERANCES

Pentures,
serrures et
pièces de fixation
*Patch fittings
and locks*

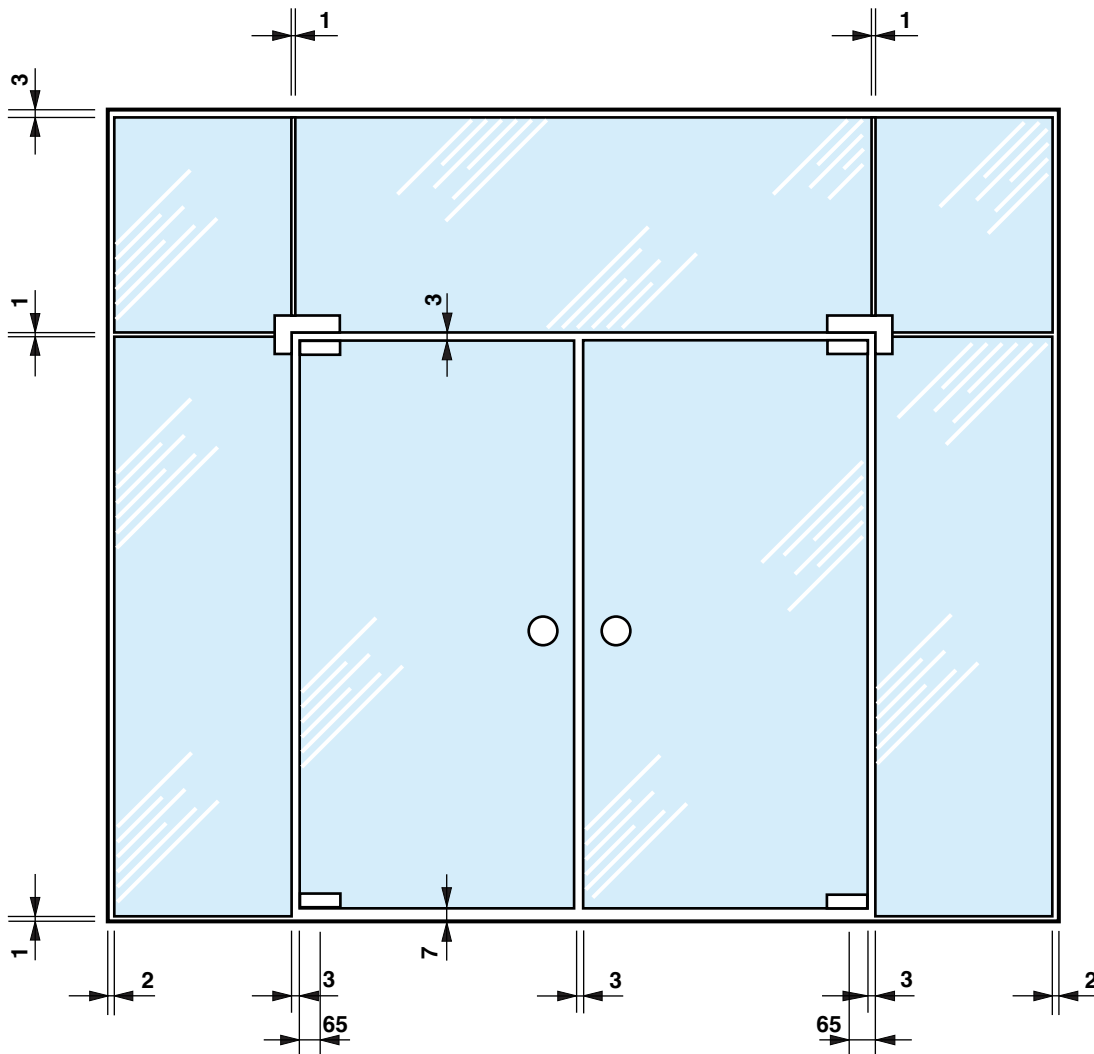

Pentures,
serrures et
pièces de fixation
*Patch fittings
and locks*

PF500D

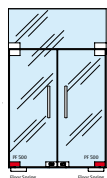
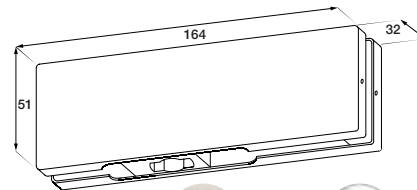
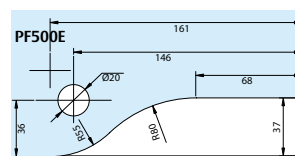

Références / References

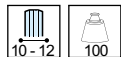

Penture basse pour axe rectangulaire allemand
Bottom Patch fitting for German Spindle

- Axe de rotation à 65 mm
- Axis of rotation, 65 mm



PF500D.15

PF500D.16



LES + PRODUITS

The + product

Grande qualité
de finition
Gamme complète
Réversibles

*High quality finishes
Full range
Reversible*

PF501

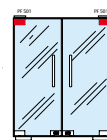
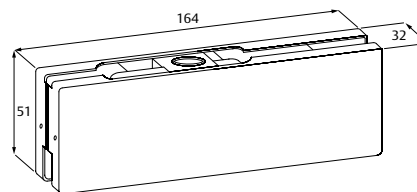
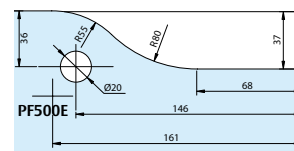

Références / References



Penture haute
Top Patch fitting

- Axe de rotation à 65 mm
- Axis of rotation, 65 mm



PF501.15

PF501.16

PF535

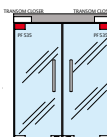
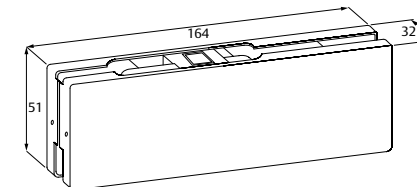
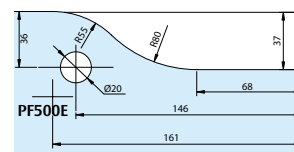

Références / References

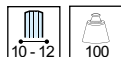

Penture haute pour ferme porte 5600
Top patch fitting for door closer 5600

- Axe de rotation à 65 mm
- Axis of rotation, 65 mm



PF535.15

PF535.16

PF502

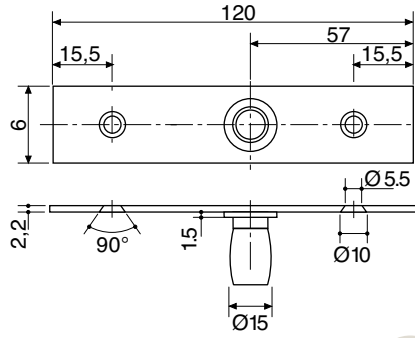

Pentures,
serrures et
pièces de fixation
*Patch fittings
and locks*

Références / References

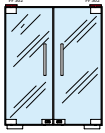

Pivot supérieur pour PF501
Top pivot for PF501



Inox Brossé
Brushed stainless steel

PF502 .15

AC299.33

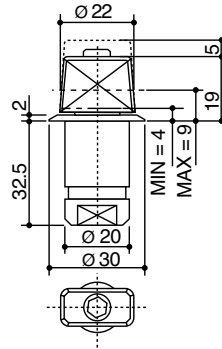

Références / References

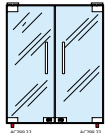

Crapaudine à sceller axe rectangulaire allemand
Adjustable German rectangular free swing floor pivot



PF581

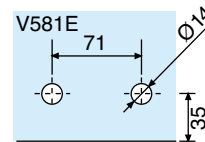
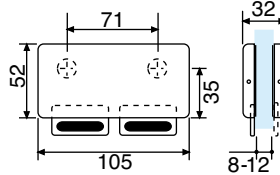
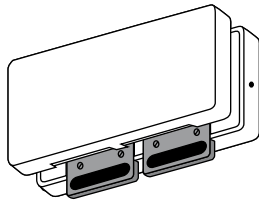

Références / References



Butée réversible pour porte double avec imposte
Reversible stop for double doors with transom



Inox Brossé
Brushed stainless steel



Inox poli
Polished stainless steel

PF581.15

PF581.16

Pentures,
serrures et
pièces de fixation
*Patch fittings
and locks*

PF511.1

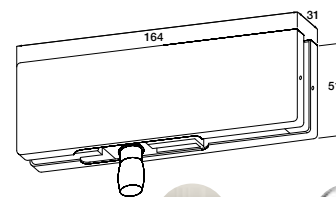
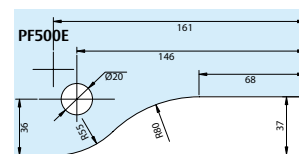

Inox Brossé
Brushed stainless steel



Inox poli
Polished stainless steel

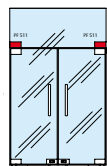

Références / References



Contre-sabot d'imposte avec tige filetée et cheville
Side fixed transom panel patch with rod and plug

PF511.1.15

PF511.1.16



LES + PRODUITS

The + product

Grande qualité
de finition
Gamme complète
Réversibles

*High quality finishes
Full range
Reversible*

PF508

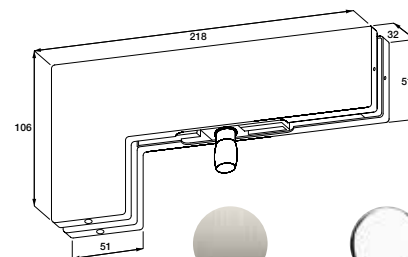
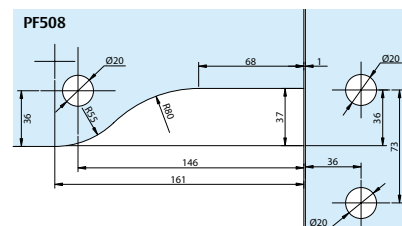

Inox Brossé
Brushed stainless steel



Inox poli
Polished stainless steel

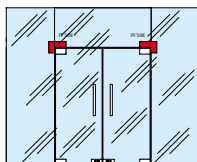

Références / References



Pièce de liaison imposte et glace fixe avec pivot
Transom and side panel link patch with pivot

PF508.15

PF508.16

PF510

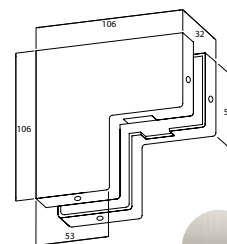
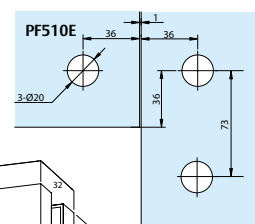

Inox Brossé
Brushed stainless steel



Inox poli
Polished stainless steel

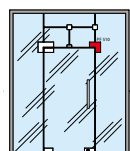

Références / References



Pièce de liaison imposte et glace fixe avec butée réversible
Transom and side panel link patch with reversible stop

PF510.15

PF510.16

PF514

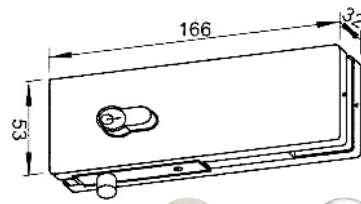
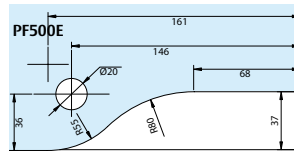

Inox Brossé
Brushed stainless steel



Inox poli
Polished stainless steel

Références / References

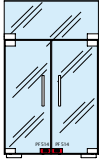

Serrure d'angle avec cylindre Européen et gâche plate
Corner Lock for Europrofile Cylinder and flat keep

PF514.15

PF514.16

Pentures,
serrures et
pièces de fixation
*Patch fittings
and locks*

PF518.1

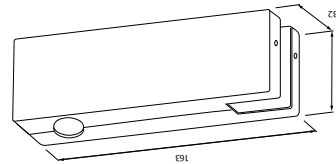
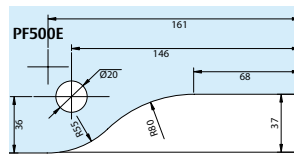

Inox Brossé
Brushed stainless steel



Inox poli
Polished stainless steel

Références / References

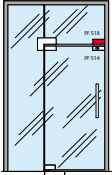

Contre-boîtier avec tige filetée pour serrure de coin PF514
Side fixed transom panel patch with rod and plug for PF514 corner lock

PF518.1.15

PF518.1.16

PF528

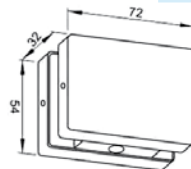
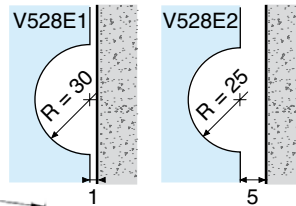

Inox Brossé
Brushed stainless steel



Inox poli
Polished stainless steel

Références / References

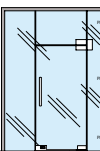

Pièce de fixation murale pour glaces fixes à vis (Montage sur encoche V528E1-V528E2)
Wall to glass patch for fixed panel to screw on (Assembly on notch V528E1-V528E2)

PF528.15

PF528.16

Pentures,
serrures et
pièces de fixation
*Patch fittings
and locks*



PF242

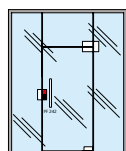
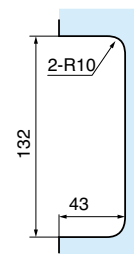
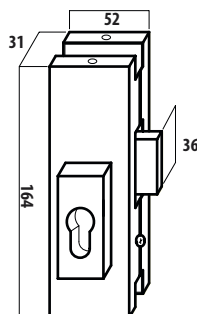

Références / References



Serrure centrale avec cylindre européen
Center lock with euro profile cylinder



Inox Brossé
Brushed stainless steel

PF242.15



Inox poli
Polished stainless steel

PF242.16

PF243

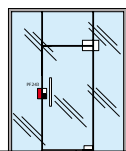
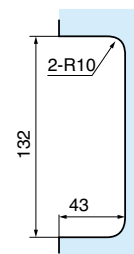
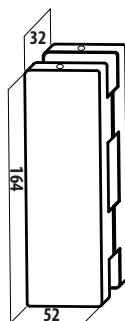

Références / References



Boîtier gâche pour PF242
Marching patch keep for lock PF242



Inox Brossé
Brushed stainless steel

PF243.15



Inox poli
Polished stainless steel

PF243.16



Serrures anti-paniques
Anti-panic locks

ASSA ABLOY

Serrures
anti-paniques
Anti-panic locks

Fermeture anti-panique

Panic exit device

Caractéristiques techniques

- Pour verre trempé de 10 et 12 mm.
- Mécanisme réversible
- Système avec 1 - 2 ou 3 points de verrouillage.
- Convient aux portes simples ou doubles
- Anti-paniques avec poignée de manoeuvre extérieur réf MNS1040H.35
- Certifié CE (EN1125) pour portes sur charnières ou sur pivots avec un poids maxi de 200 kg, hauteur maxi 2600 mm et une largeur maxi 1320 mm.

Technical features

- For toughened glass doors 10 and 12 mm
- Reversible
- System with 1-2 or 3 locking points.
- Suitable for single or double doors
- Panic device with outside handle ref MNS1040H.35
- CE certified (EN1125) for doors on hinges or pivots with weight over 200kg,



LES + PRODUITS

The + product

Adaptée
pour porte en verre
Installation facile
Garantie 5 ans

*Adapted
to glass doors
Easy installation
5 years warranty*

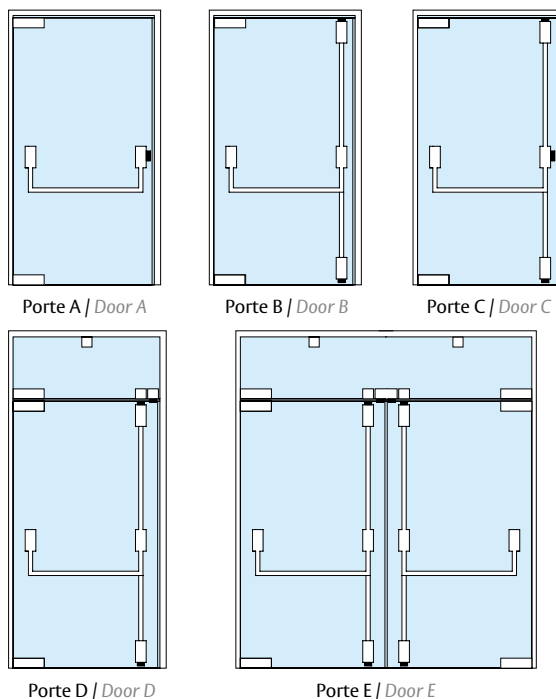

Closing type - Type de condamnation

ARTICLES NECESSAIRES - REFERENCES NEEDED

Type de condamnation <i>Closing type</i>	MS429060.35 sans poignée extérieure <i>without ext handle</i>	MS342900.35	MS4432.35
Porte A / <i>Door A</i>	1		
Porte B / <i>Door B</i>	1	1	
Porte C / <i>Door C</i>	1	1	
Porte D / <i>Door D</i>	1	1	1
Porte E / <i>Door E</i>	2	2	2

MS429060.35

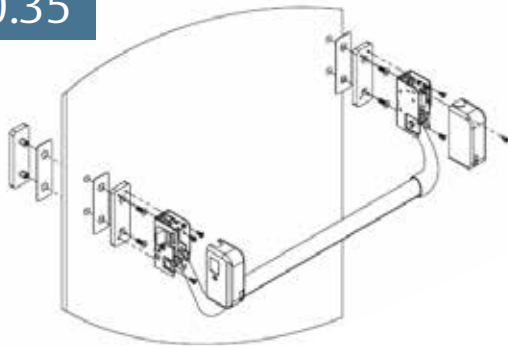

Références / References



Barre anti-panique pour sortie de secours sans poignée extérieure avec accessoires de montage pour le verre
Anti-panic device without outside handle with accessories for glass door installation



Effet Inox
Stainless steel effect

MS429060.35

MS429060H.35

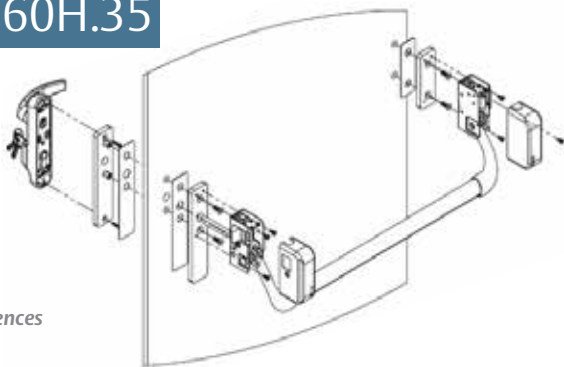

Références / References



Barre anti-panique pour sortie de secours avec poignée extérieure avec accessoires de montage pour le verre
Anti-panic device with outside handle with accessories for glass door installation



Effet Inox
Stainless steel effect

MS429060H.35

MS342900.35

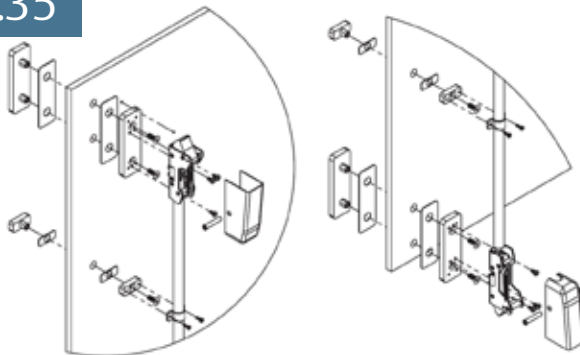

Références / References



Mécanisme de fermeture supérieur et inférieur avec tringles et gâches, pour porte jusqu'à 2600 mm avec accessoires de montage pour le verre
Top and bottom latches, strikers and vertical rods for doors up to 2600 mm with accessories for glass door installation



Effet Inox
Stainless steel effect

MS342900.35

MS4432.35

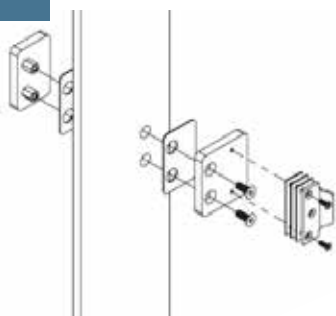

Références / References



Boîtier gâche pour montage sur verre
Matching patch keep for glass door installation



Effet Inox
Stainless steel effect

MS4432.35

Serrures
anti-paniques
Anti-panic locks

Serrures
anti-paniques
Anti-panic locks

Encoches pour fermeture anti-panique

Panic exit device knockes



LES + PRODUITS
The + product

Adaptée
pour porte en verre
Garantie 5 ans

Adapted
to glass doors
5 years warranty

①

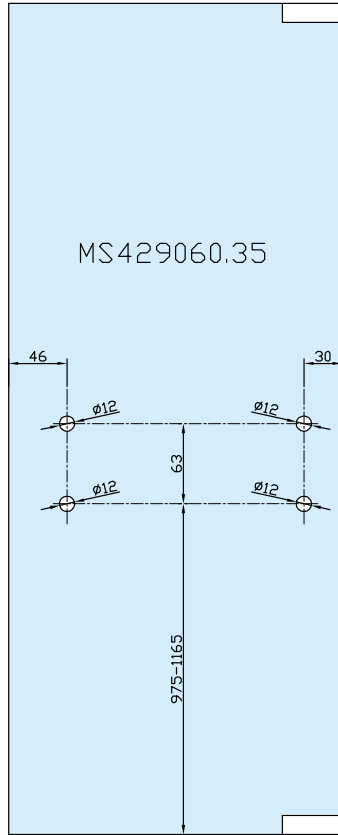

②

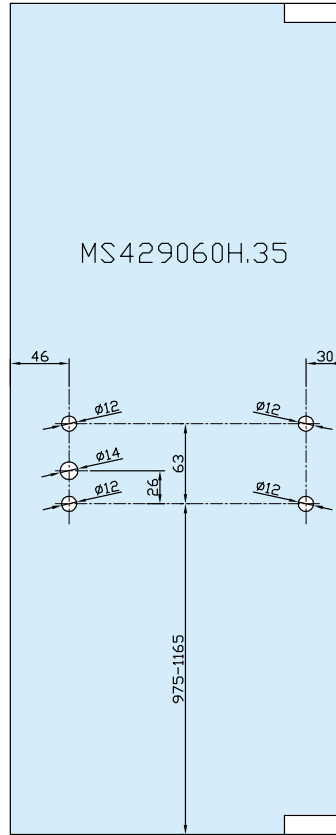

③

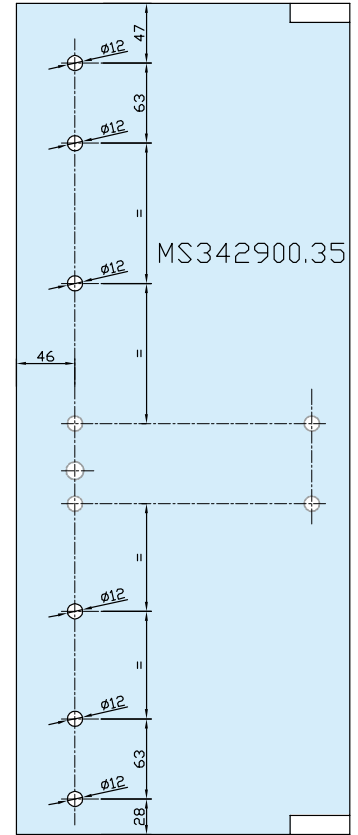

④

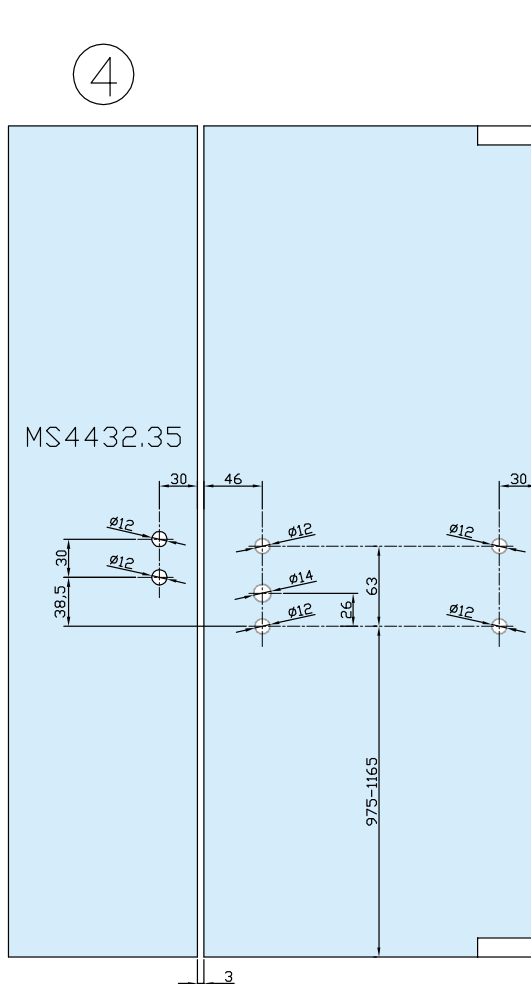

⑤

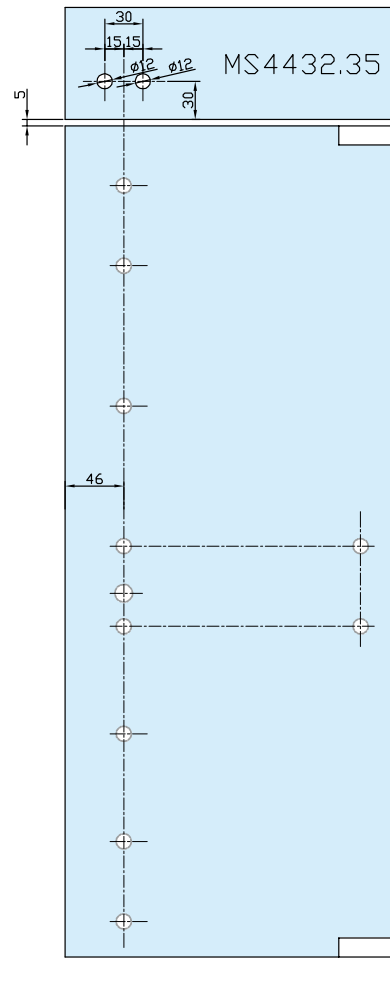



Plinthes
Door rails

ASSA ABLOY

Série FRP



Caractéristiques techniques

- Hauteur 100 mm
- Pour verre de 10 et 12 mm
- Montage sans encoche
- Poids maximum 300 kg
- Porte maxi 1400 x 2400 mm
- Montage à l'aide de vis invisible

Technical features

- Height 100 mm
- For 10 and 12 mm thick glass
- No notches needed
- Maximum door weight 300 kg
- Maximum door size 1400 x 2400 mm
- Clamping by using invisible screws

Jeux recommandés.

Recommended tolerances.

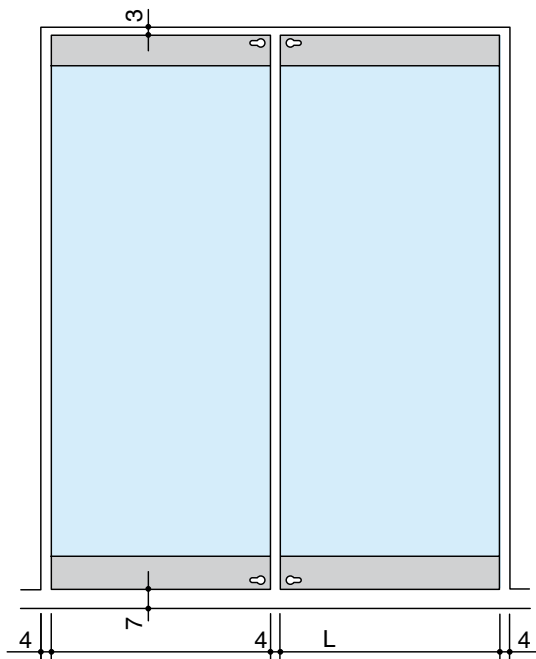

Préparation du verre.

Glass preparation.

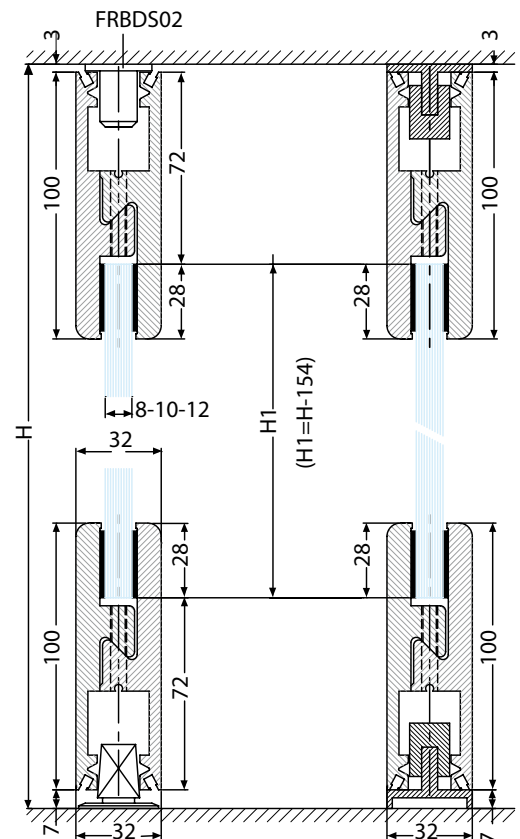

Porte
Door

Panneau fixe
Fixed panel

FRBDS02.99

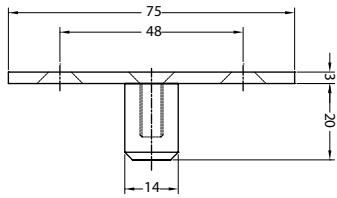

Pivot haut pour plinthe haute FRP02

Top pivot for top door rail FRP02

AC246.33

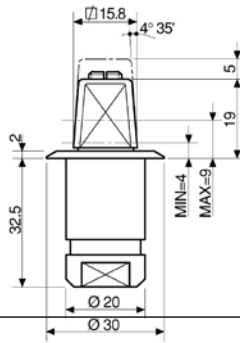

Crapaudine à sceller réglable axe carré italien

Adjustable Italian square floor pivot, to be embedded

FRP02B

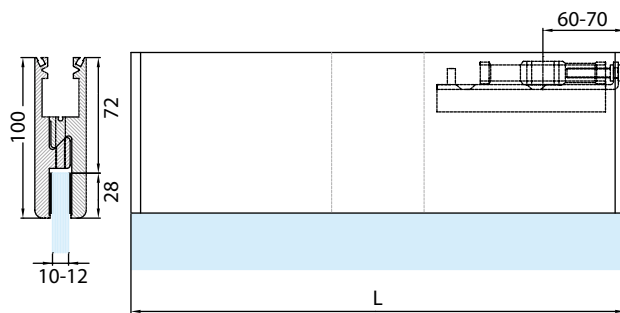
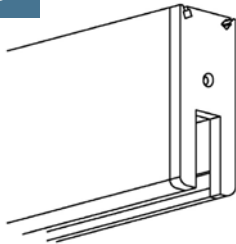

Références / References

Plinthe supérieure hauteur 100 mm avec insert et embouts
Top rail 100 mm high with pivot block and end caps

Aluminium anodisé Argent Brossé
Brushed anodised alu. silver



Pour verre de 10 mm
For 10 mm glass

FRP02B/10.12



Pour verre de 12 mm
For 12 mm glass

FRP02B/12.12

FRP02BL

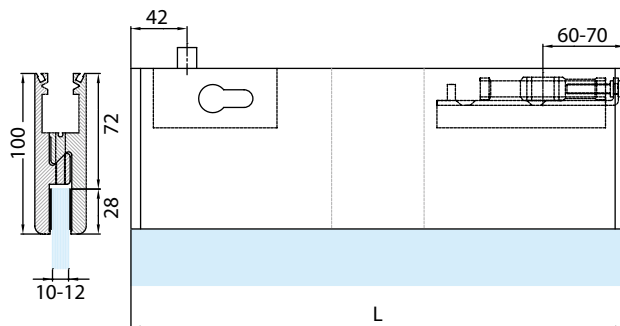
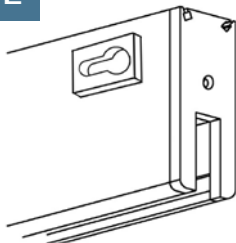

Références / References

Plinthe supérieure hauteur 100 mm avec insert, embouts, serrure et cylindre
Top rail 100 mm high with pivot block, end caps, lock and cylinder

Aluminium anodisé Argent Brossé
Brushed anodised alu. silver



Pour verre de 10 mm
For 10 mm glass

FRP02BL/10.12



Pour verre de 12 mm
For 12 mm glass

FRP02BL/12.12

FRP020

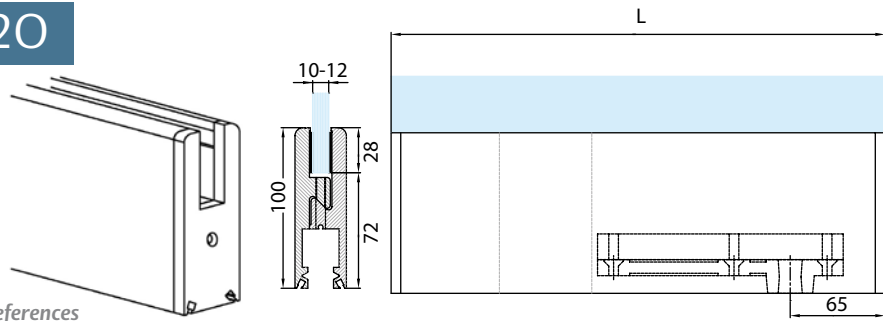

Références / References

-   Plinthe inférieure hauteur 100 mm avec insert carré italien et embouts
Bottom rail 100 mm high with Italian square spindle and end caps

Aluminium anodisé Argent Brossé
Brushed anodised alu. silver

-  Pour verre de 10 mm
For 10 mm glass

FRP020/10.12

-  Pour verre de 12 mm
For 12 mm glass



FRP020/12.12

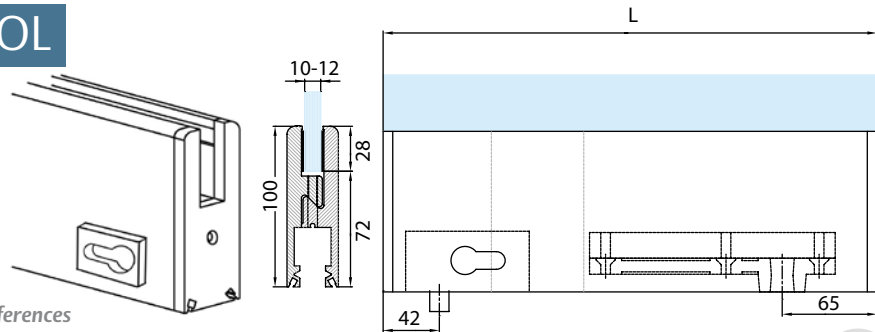

FRP020L



Références / References

-   Plinthe inférieure hauteur 100 mm avec insert carré italien, embouts, serrure et cylindre
Bottom rail 100 mm high with Italian square spindle and end caps, lock and cylinder

Aluminium anodisé Argent Brossé
Brushed anodised alu. silver

-  Pour verre de 10 mm
For 10 mm glass

FRP020L/10.12

-  Pour verre de 12 mm
For 12 mm glass

FRP020L/12.12

FRP07B

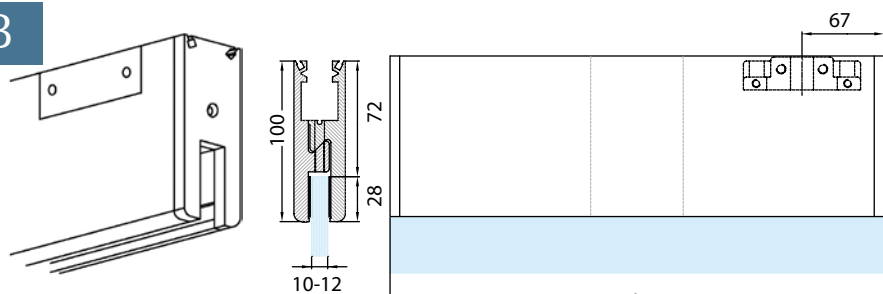

Références / References

- Plinthe supérieure hauteur 100 mm avec insert pour ferme porte encastré série 5600 et embouts
Top rail 100 mm high with pivot block for closers series 5600 and end caps

Aluminium anodisé Argent Brossé
Brushed anodised alu. silver

-  Pour verre de 10 mm
For 10 mm glass

FRP07B/10.12

-  Pour verre de 12 mm
For 12 mm glass

FRP07B/12.12

FRP07BL

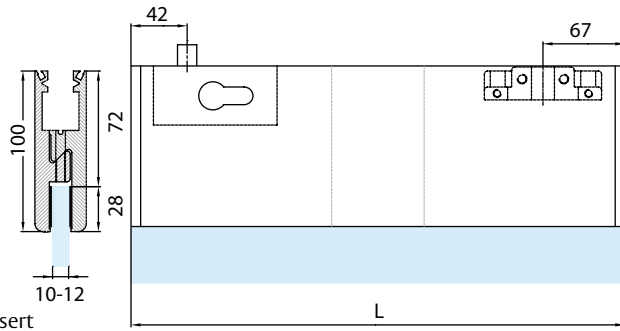
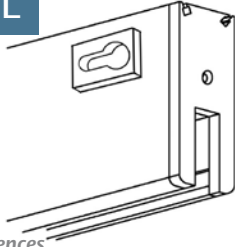

Références / References

Plinthe supérieure hauteur 100 mm avec insert pour ferme porte encastré série 5600 et embouts
Top rail 100 mm high with pivot block for closers series 5600 and end caps

Aluminium anodisé Argent Brossé
Brushed anodised alu. silver



Pour verre de 10 mm
For 10 mm glass

FRP07BL/10.12



Pour verre de 12 mm
For 12 mm glass

FRP07BL/12.12

FRP06B

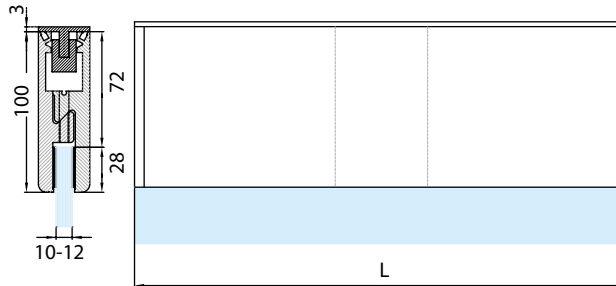
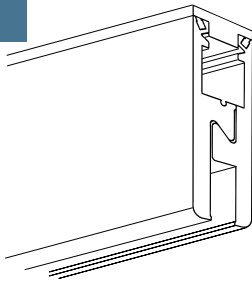

Références / References

Plinthe haute sans embout, hauteur 100 mm pour volumes fixes + Profilé supérieur de remplissage 3 mm
Top rail 100 mm high for fixed panels, without end caps + 3 mm Top filler profile

Aluminium anodisé Argent Brossé
Brushed anodised alu. silver



Pour verre de 10 mm
For 10 mm glass

FRP06B/10.12



Pour verre de 12 mm
For 12 mm glass

FRP06B/12.12

FRP06O

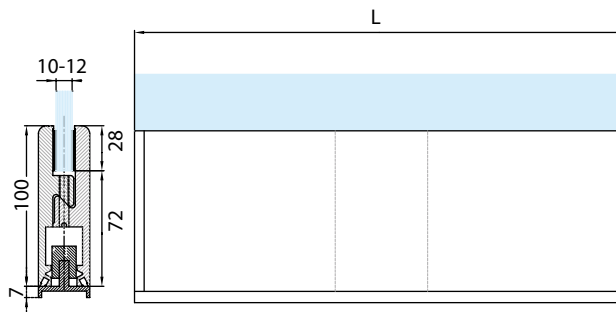
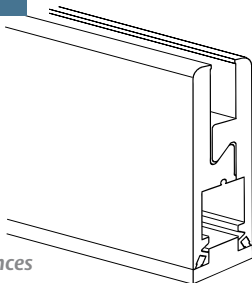

Références / References

Plinthe basse sans embout, hauteur 100 mm pour volumes fixes + Profilé inférieur de remplissage 7 mm
Bottom rail 100 mm high for fixed panels, without end caps + 7 mm bottom filler profile

Aluminium anodisé Argent Brossé
Brushed anodised alu. silver



Pour verre de 10 mm
For 10 mm glass

FRP06O/10.12



Pour verre de 12 mm
For 12 mm glass

FRP06O/12.12

FRE14

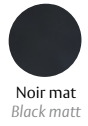
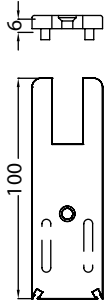

Références / References

Embout noir avec vis
Black end cap including screw

FRE14.73

FRE14.74



FRB**

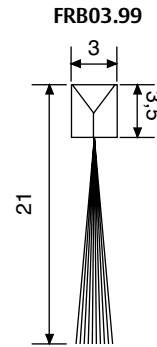
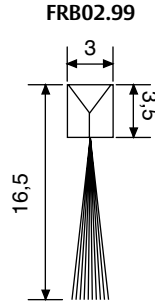
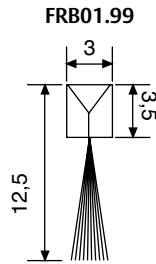

Références / References

Brosse d'étanchéité longueur 2 m pour jeu de 7 mm
Brushes length 2m for a tolerance of 7 mm

FRB01.99

Brosse d'étanchéité longueur 2 m pour jeu de 9 mm
Brushes length 2m for a tolerance of 9 mm

FRB02.99

Brosse d'étanchéité longueur 2 m pour jeu de 13 mm
Brushes length 2m for a tolerance of 13 mm

FRB03.99

V515

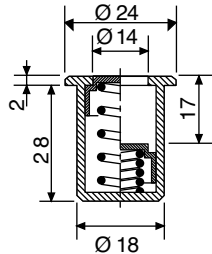

Chromé mat brossé
Brushed matt chromium

Références / References

Gâche anti-poussière pour plinthe FRP02OL
Tubular dustproof bolt keep for FRP02OL

V515.33

V532

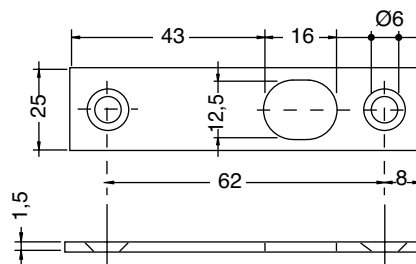

Inox Brossé
Brushed stainless steel

Références / References

Gâche pour FRP02BL ou FRP02OL
Flat keep for FRP02BL or FRP02OL

V532.15





Caractéristiques techniques

- Pour verre de 8, 10, 12, 15 et 19 mm
- Montage sans encoche

Technical features

- For 8, 10, 12, 15 and 19 mm thick glass
- No notches needed

2810.xx.L3000

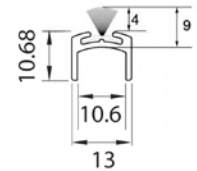

Références / References



Aluminium anodisé Argent Brossé
Brushed anodised alu. silver



Aluminium anodisé Aninox
Brushed anodised alu. aninox

Joint U avec brosse centrale
U profile with brush

2810.12.L3000

2810.36.L3000

2812.xx.L3000

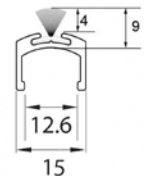

Références / References



Aluminium anodisé Argent Brossé
Brushed anodised alu. silver



Aluminium anodisé Aninox
Brushed anodised alu. aninox

Joint U avec brosse centrale
U profile with brush

2812.12.L3000

2812.36.L3000

2809.**.4

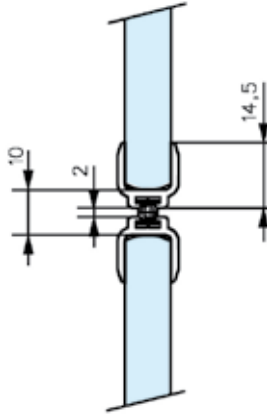
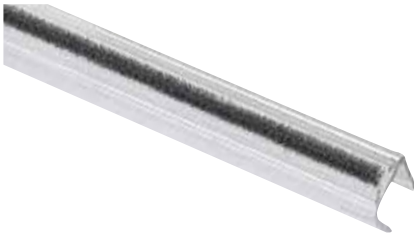

Références / References



Translucide
Translucent

Joint translucide avec brosse axée
Translucent sealing strip with central brush

2809.66.4

2810.10.*

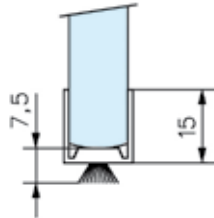

Références / References

Joint aluminium avec brosse axée
Aluminium sealing strip with central brush



Aluminium anodisé Argent satiné
Satin anodised alu. silver



Pour verre de 8 mm
For 8 mm glass

2810.10.3

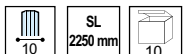

Pour verre de 10 mm
For 10 mm glass

2810.10.4

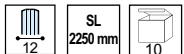

Pour verre de 12 mm
For 12 mm glass

2810.10.5

2811.10.*

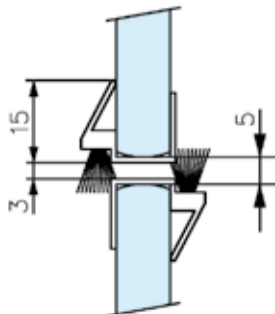

Références / References

Joint aluminium avec brosse déportée
Aluminium sealing strip with off set brush



Aluminium anodisé Argent satiné
Satin anodised alu. silver

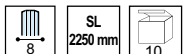

Pour verre de 8 mm
For 8 mm glass

2811.10.3

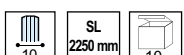

Pour verre de 10 mm
For 10 mm glass

2811.10.4

FRKB01.99

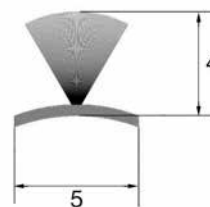

Brosse autocollante pour toutes les épaisseurs de verre - le mètre
Brush self-adhesive for all glass thicknesses - per metre



28131



Références / References

Joint aluminium avec brosse autocollante longueur 1030mm pour toutes les épaisseurs de verre
Aluminium brush profile self-adhesive length 1030mm for all glass thicknesses

- Livré avec 2 embouts

- Supplied with 2 end caps

Aluminium anodisé Argent Brossé
Brushed anodised alu. silver

28131.12

2813N

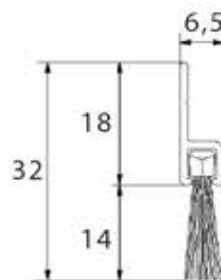

Références / References

Joint aluminium avec brosse autocollante longueur 2500 mm pour toutes les épaisseurs de verre
Aluminium brush profile self-adhesive length 2500 mm for all glass thicknesses

2813N.12

Aluminium anodisé Argent Brossé
Brushed anodised alu. silver

Plinthe automatique pour porte en verre

Drop-down seal for glass door

2815L833.*

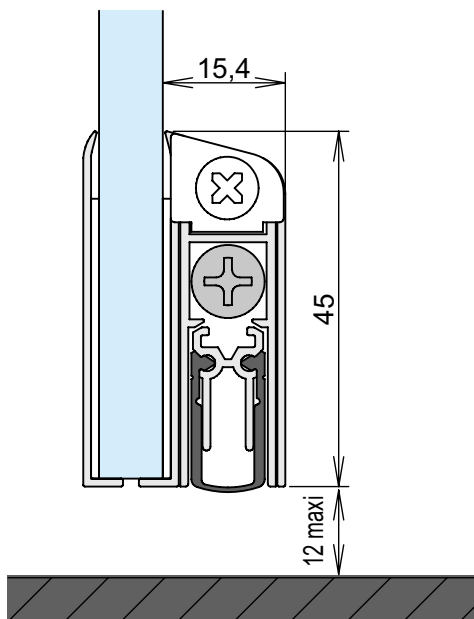

- Optimise l'isolation acoustique et thermique de la porte
- Pas d'encoche
- Installation possible sur porte existante ou neuve
- Testé pour plus de 1 000 000 de cycles
- Optimize the soundproofing and thermal insulation
- No notches
- Possible installation on existing or new doors
- Tested for more than 1,000,000 cycles

Références / References

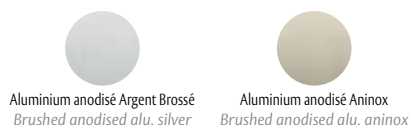

Joint bas de porte automatique avec cache adhésif Lg 708-833 mm <i>Drop down seal self adhesive with cover L 708-833 mm</i>	2815L833.12	2815L833.36
Joint bas de porte automatique avec cache adhésif Lg 833-958 mm <i>Drop down seal self adhesive with cover L 833-958 mm</i>	2815L958.12	2815L958.36
Joint bas de porte automatique avec cache adhésif Lg 953-1083 mm <i>Drop down seal self adhesive with cover L 953-1083 mm</i>	2815L1083.12	2815L1083.36
Joint bas de porte automatique avec cache adhésif Lg 1083-1208 mm <i>Drop down seal self adhesive with cover L 1083-1208 mm</i>	2815L1208.12	2815L1208.36

U151515



Références / References

SL
6000 mm

Profil U 15x15x15x2mm (le mètre)
U-profile 15x15x15x2mm (per metre)



Aluminium anodisé Argent Brossé
Brushed anodised alu. silver



Aluminium anodisé Aninox
Brushed anodised alu. aninox



Laqué blanc 9010
Lacquered white RAL 9010

U151515.12

U151515.36

U151515.51



U202020



Références / References

SL
6000 mm

Profil U 20x20x20x2mm (le mètre)
U-profile 20x20x20x2mm (per metre)



Aluminium anodisé Argent Brossé
Brushed anodised alu. silver



Aluminium anodisé Aninox
Brushed anodised alu. aninox

U202020.12

U202020.36

U302030



Références / References

SL
6000 mm

Profil U 30x20x30x2mm (le mètre)
U-profile 30x20x30x2mm (per metre)



Aluminium anodisé Argent Brossé
Brushed anodised alu. silver



Aluminium anodisé Aninox
Brushed anodised alu. aninox

U302030.12

U302030.36



Profils U et L décor alu poli brillant

U and L profiles Polished aluminium finish



Alu poli brillant
Polished aluminium

Références / References

Profil U 15x15x15x2 mm largeur intérieure 11 mm longueur de 3000 mm <i>U-profile 15x15x15x2 mm 11 mm inside width 3000 mm length</i>	U151515.13
Profil U 20x12x20x1,5 mm largeur intérieure 9 mm longueur de 3000 mm <i>U-profile 20x12x20x1,5 mm 9 mm inside width 3000 mm length</i>	U201220.13
Profil U 20x15x20x2 mm largeur intérieure 11 mm longueur de 3000 mm <i>U-profile 20x15x20x2 mm 11 mm inside width 3000 mm length</i>	U201520.13
Profil U 20x17x20x2 mm largeur intérieure 13 mm longueur de 3000 mm <i>U-profile 20x17x20x2 mm 13 mm inside width 3000 mm length</i>	U201720.13
Profil U 20x20x20x2 mm largeur intérieure 16 mm longueur de 3000 mm <i>U-profile 20x20x20x2 mm 16 mm inside width 3000 mm length</i>	U202020.13
Profil U 30x20x30x2 mm largeur intérieure 16 mm longueur de 3000 mm <i>U-profile 30x20x30x2 mm 16 mm inside width 3000 mm length</i>	U302030.13
Profil U 40x20x40x2 mm largeur intérieure 16 mm longueur de 3000 mm <i>U-profile 40x20x40x2 mm 16 mm inside width 3000 mm length</i>	U402040.13
Profil L 15x15x2 mm longueur de 3000 mm <i>L-profile 15x15x2 mm 3000 mm length</i>	L1515.13
Profil L 20x20x2 mm longueur de 3000 mm <i>L-profile 20x20x2 mm 3000 mm length</i>	L2020.13
Profil L 25x25x2 mm longueur de 3000mm <i>L-profile 25x25x2 mm 3000 mm length</i>	L2525.13

Quantités minimum de commande par référence = 5 longueurs

Quantités de lots par référence = 5 longueurs

Minimum quantity per order and per reference = 5 lengths

Sold in packs per reference = 5 lengths

KL001

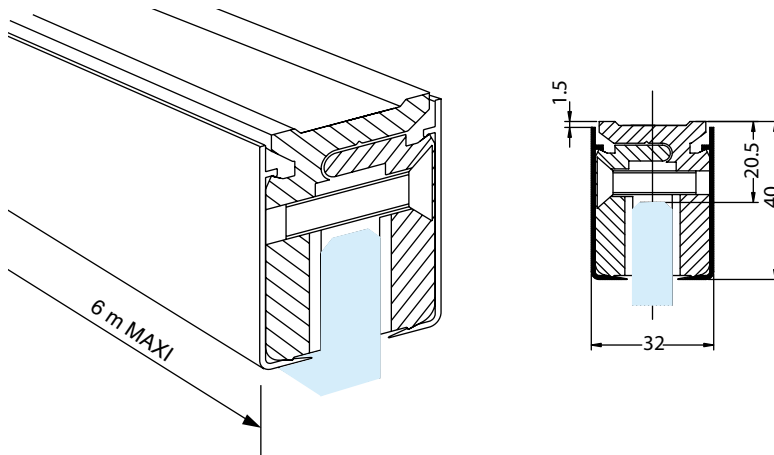

Verre suspendu poids maxi : 40 kg par mètre courant
Hanging glass maximum weight : 40 kg per running metre

Références / References

EL 6000	40	Profil de serrage pour panneaux fixes avec caches, sans encoches (le mètre) Glass clamp profile incl. covers, no notch (per meter)	Aluminium anodisé Argent Brossé Brushed anodised alu. silver	Aluminium anodisé Aninox Brushed anodised alu. aninox
		Pour verre de 8 mm For 8 mm glass	KL001/08.12	KL001/08.36
		Pour verre de 10 mm For 10 mm glass	KL001/10.12	KL001/10.36
		Pour verre de 12 mm For 12 mm glass	KL001/12.12	KL001/12.36

KL002

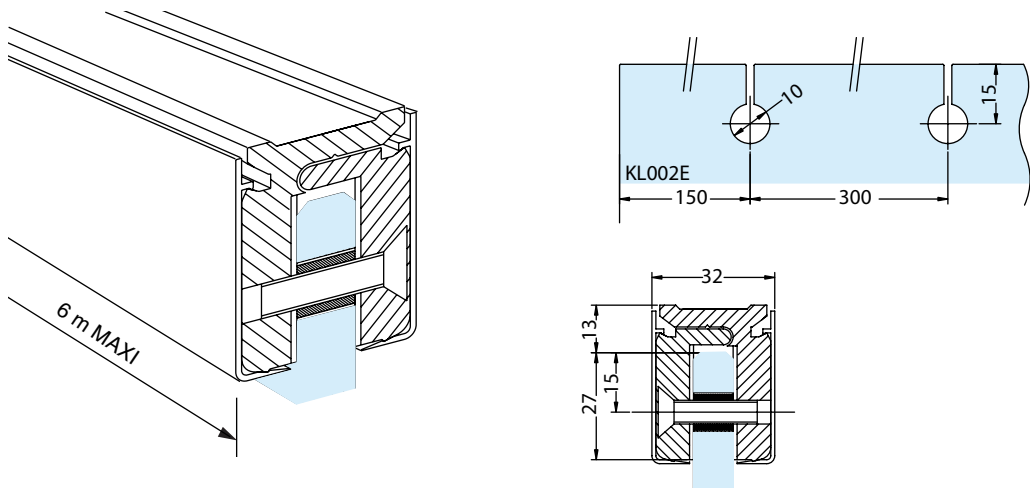

Verre suspendu poids maxi : 40 kg par mètre courant (le mètre)
Hanging glass maximum weight : 40 kg per running metre (per meter)

Références / References

EL 6000	40	Profil de serrage avec caches pour panneaux fixes avec trous (le mètre) Glass clamp profile incl. covers for glass with holes notches (per meter)	Aluminium anodisé Argent Brossé Brushed anodised alu. silver	Aluminium anodisé Aninox Brushed anodised alu. aninox
		Pour verre de 8 mm For 8 mm glass	KL002/08.12	KL002/08.36
		Pour verre de 10 mm For 10 mm glass	KL002/10.12	KL002/10.36

KL003

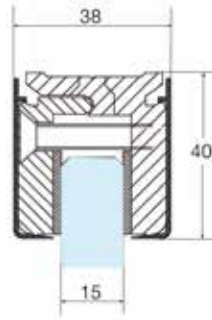
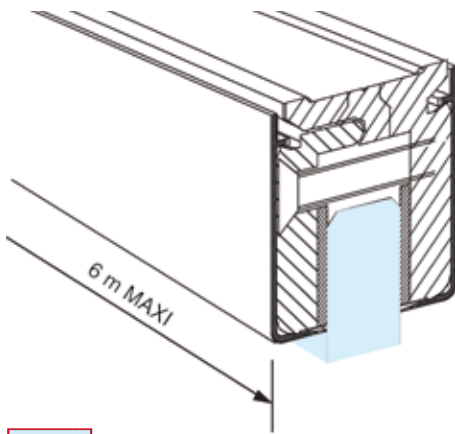

Verre suspendu poids maxi : 40 kg par mètre courant.
Hanging glass maximum weight : 40 kg per running metre

Références / References

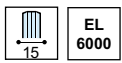

Aluminium anodisé Argent Brossé
Brushed anodised alu. silver



Aluminium anodisé Aninox
Brushed anodised alu. aninox

Profil de serrage pour panneaux fixes avec caches (le mètre)
Glass clamp profile incl. covers (per metre)

KL003.12

KL003.36

KL005

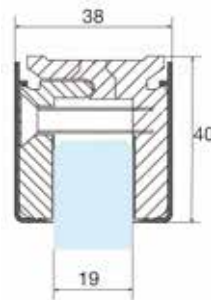
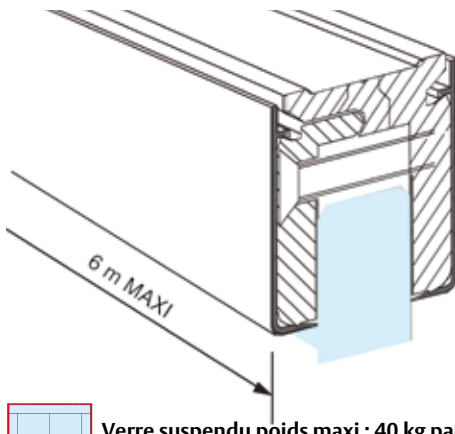

Verre suspendu poids maxi : 40 kg par mètre courant
Hanging glass maximum weight : 40 kg per running metre

Références / References

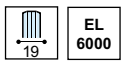

Aluminium anodisé Argent Brossé
Brushed anodised alu. silver



Aluminium anodisé Aninox
Brushed anodised alu. aninox

Profil de serrage pour panneaux fixes avec caches
Glass clamp profile incl. covers

KL005.12

KL005.36

KLA01

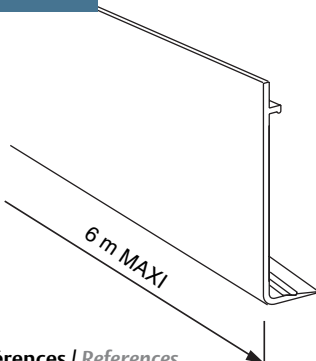

Références / References



Caches pour profil de serrage KL001 - KL002 - KL003 - KL005
Covers for glass clamp profile KL001 - KL002 - KL003 - KL005



Aluminium anodisé Argent Brossé
Brushed anodised alu. silver



Aluminium anodisé Aninox
Brushed anodised alu. aninox

KLA01.12

KLA01.36

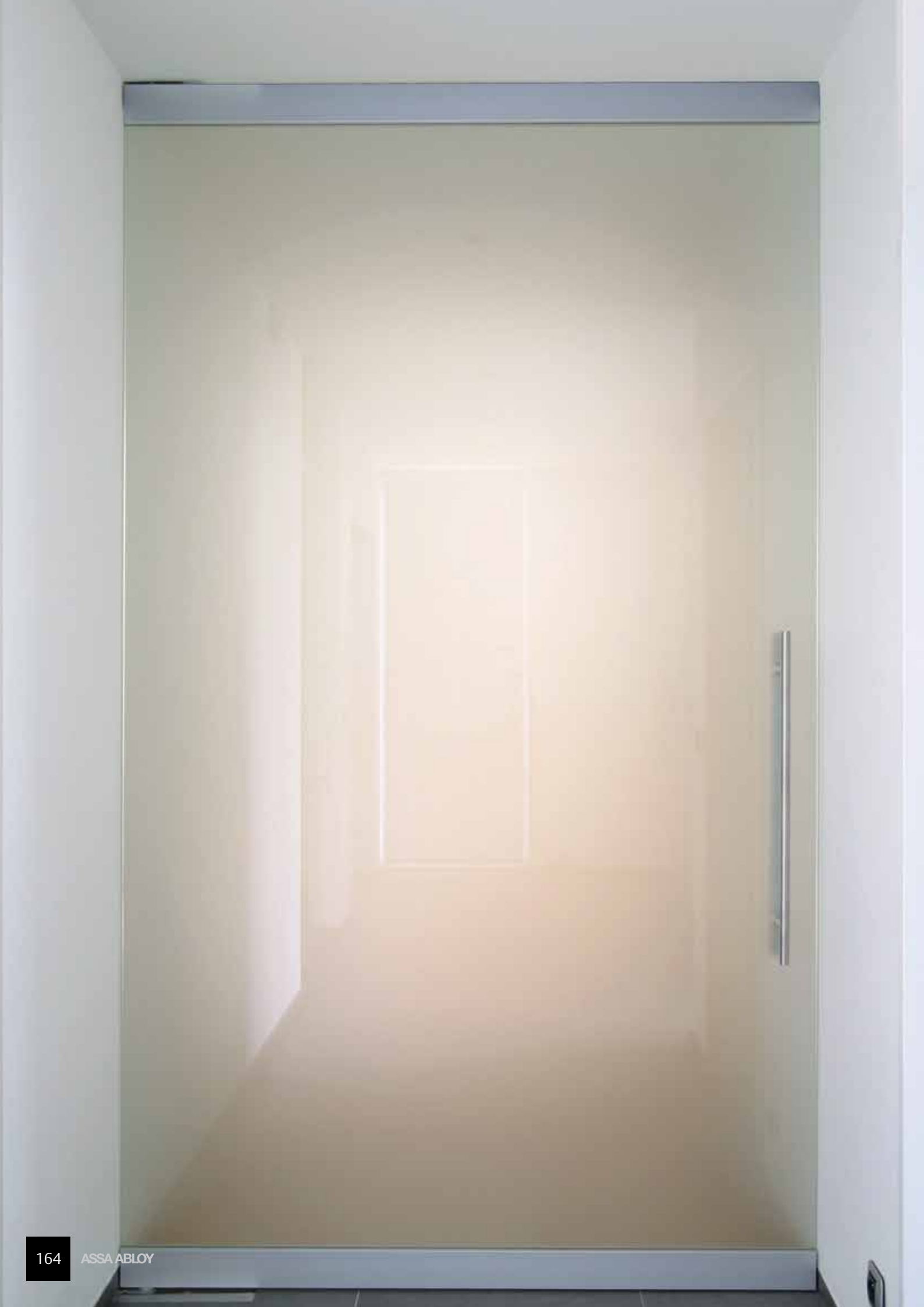



Pivots de sol et ferme-portes
Floor springs and door closers

ASSA ABLOY

Pivots de sol et
ferme-portes
Floor springs and
door closers

Ferme-porte pour porte en verre

Door closer for glass door

Caractéristiques techniques

- Technologie à came
- Force réglable 1-4 EN
- Vitesse de fermeture, et à-coup final réglable
- Système de blocage intégré réglable
- Marque CE

Technical features

- Cam Motion technology
- Adjustable force EN 1-4
- Adjustable closing speed, latching speed and back check
- Integrated hold open device adjustable to the desired angle
- CE Marked

DC500.73

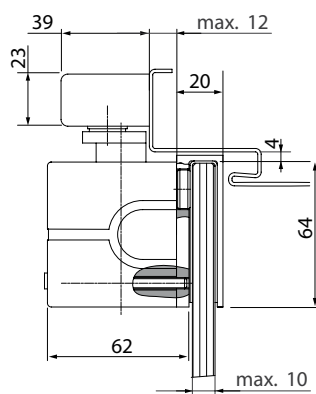
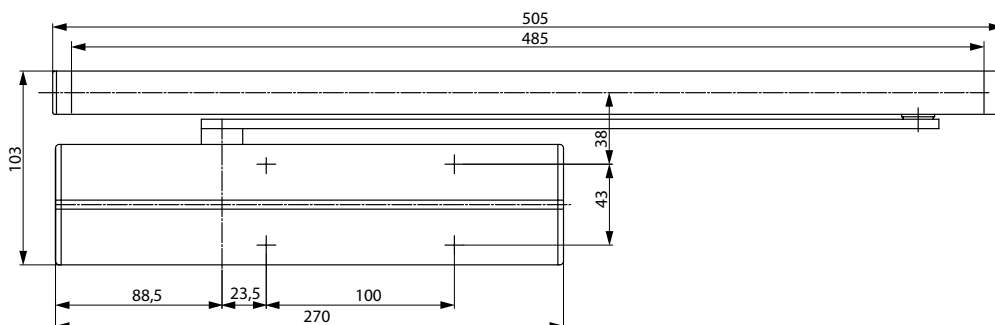

Laqué argent
Lacquered silver



Ferme-porte avec arrêt réglable et cavalier.
Door closer with hold open for tempered glass doors

DC500.73

Cale de compensation 25 mm pour ferme porte DC500
Shims 25 mm thick for door closer DC500

AC500.25.73

Ouvre-porte Autoswing

Autoswing door opener

Pivots de sol et
ferme-portes
Floor springs and
door closers



AUTOSWING

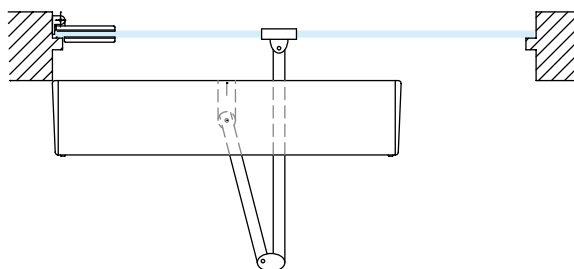
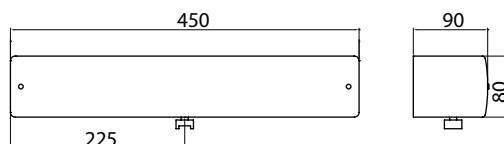

Références / References

Opérateur d'ouvre porte intérieur, complet avec cache, bras et cavalier pour porte en verre
Operator for single action interior door complete with cover and arm with clip-on U plate for glass door

AUTOSWING.73

Alimentation	230 V~ 50/60 Hz 24 V
Puissance consommée	120 W
Degré d'utilisation	Classe 5 - TRÈS INTENSE (600 cycles/jour)
Type de fonctionnement	Fermeture à moteur/Ouverture à moteur
Poids maximum pour 1 porte de largeur max 1000 mm	100 kg
Poids maximum pour 1 porte de largeur max 1200 mm	80 kg
Sortie moteur	24 V 3,5 A
Alimentation des accessoires	24 V 0,3 A

Power supply	230 V~ 50/60 Hz 24 V
Power consumption	120 W
Degree of use	Classe 5 - TRÈS INTENSE (600 cycles/jour)
Operation type	Fermeture à moteur/Ouverture à moteur
Maximum weight for 1 door width 1000 mm max	100 kg
Maximum weight for 1 door width 1200 mm max	80 kg
Motor power	24 V 3,5 A
Accessories power supply	24 V 0,3 A



Argent métallisé
Metallic silver

Pivots de sol et
ferme-portes
*Floor springs and
door closers*

Ferme-porte encastrable série 5600

Overhead concealed door closer 5600

Caractéristiques techniques

- Force 2 ou 3 EN (16-22 Nm)
- Corps en fonte de haute résistance
- Rendement élevé mécanisme en acier trempé
- Ouverture à faible poussée
- Vitesse de fermeture et à-coup final réglables
- Contrôle hydraulique et ouverture maxi sur 120° dans les deux sens
- Arrêt à 90° ou sans arrêt
- Hauteur standard de broche 21 mm

Technical features

- Force 2 – 3 EN (16-22 Nm)
- High grade cast iron body
- High efficiency hardened steel mechanism
- Low opening force
- Two independent thermostatic valves for precise adjustment of general closing speed, final latch or final damping
- Hydraulic control and maxi opening of 120° in both directions
- Hold open at 90° or non hold open
- Standard spindle height 21 mm

- Utilisation avec penture haute PF535, penture basse PF500D et pivot bas AC299.33

- Use with top patch fitting PF535, bottom patch fitting PF500D and dome floor pivot AC299.33

LES + PRODUITS

The + product

Encastré
dans le dormant hori-
zontal

Solution esthé-
tique

*Overhead
concealed closer*

Harmonious solution



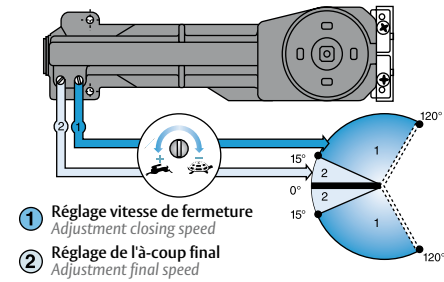
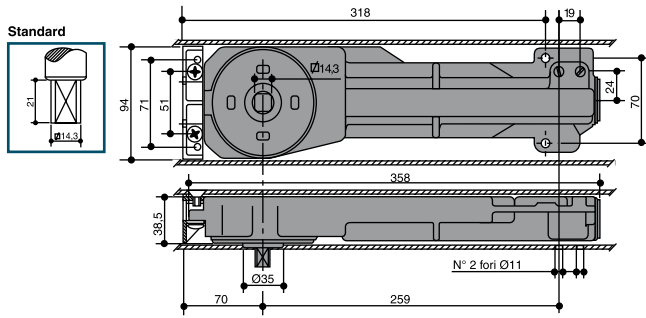

Zone sous commande hydraulique de valve 2
Area under hydraulic control of valve 2

Zone sous commande hydraulique de valve 1
Area under hydraulic control of valve 1

56XXH21

Force

Min. power **2** = 16Nm

Max. power **3** = 22Nm

min. 850 x 2200 80

max. 950 x 2300 80

Blocage *hold open*

5 = 90° 0°

2 = x 0°

Références / References

5625H21.99 Ferme-porte encastrable Force EN 2, arrêt à 90°
Overhead concealed door closer force 2 EN, hold open at 90°

5632H21.99 Ferme-porte encastrable Force EN 3, sans arrêt
Overhead concealed door closer force 3 EN, no hold open

5635H21.99 Ferme-porte encastrable Force EN 3, arrêt à 90°
Overhead concealed door closer force 3 EN, hold open at 90°

43800

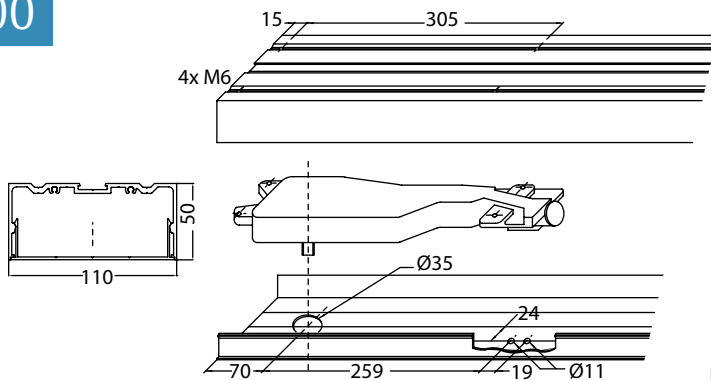

Alu anodisé argent brossé
Brushed anodised alu. silver

Aluminium anodisé Aninox
Brushed anodised alu. Aninox

Références / References

Profil pour ferme-porte encastrable séries 5600
Profile for overhead concealed door closer series 5600

43800.12

43800.36

Pivots de sol et
ferme-portes
Floor springs and
door closers

Pivots de sol série DC420

Floor springs DC420 series

Caractéristiques techniques

- Force de 2 - 3 ou 4 EN (17-22 ou 28 Nm)
- Recommandé pour les portes jusqu'à 100 kg
- Axe amovible : carré français, rectangulaire allemand, carré italien
- Arrêt à 90°, 105° et sans arrêt
- Contrôle hydraulique sur 175° dans les deux sens
- Vitesse de fermeture et à-coup final réglables
- Ouverture spécialement légère pour enfants et personnes plus âgées
- Grande amplitude d'ajustement du corps dans le boîtier de scellement : Largeur 10 mm
Longueur 10 mm
Hauteur 5 mm
- Corps en fonte et boîtier zingué

Tous les modèles ont la certification EN1154.
La version Force EN 3-4, sans blocage, est conforme à la norme CE.

Les pivots de sol sont livrés séparément : boîte, corps + axe + plaque de recouvrement.
The floor springs are supplied separately with cementing box, body + spindle + cover plate.

Technical features

- Force EN 2 - 3 or 4 (17-22 or 28 Nm)
- Recommended for doors up to 100 kg
- Variety of available spindles : French square, German rectangular, Italian square
- Hold open at 90°, 105° or non hold open
- Hydraulic control over 175° in both directions
- Two independent thermostatic valves for precise adjustment of general closing speed, final latch or final damping
- Very light duty force setting to ensure the children and elderly persons very easy access
- Large range of adjustment body setting in the cementing box : Width 10 mm
Length 10 mm
Height 5 mm
- Cast iron body and cementing box in hot zinc plated steel

All models have quality certification EN1154.
Versions force EN3-4, without hold open, have CE conformity.



LES + PRODUITS

The + product

Etroit

Réglage vertical

Axe interchangeable

Slim

Vertical adjustment

Interchangeable
spindle



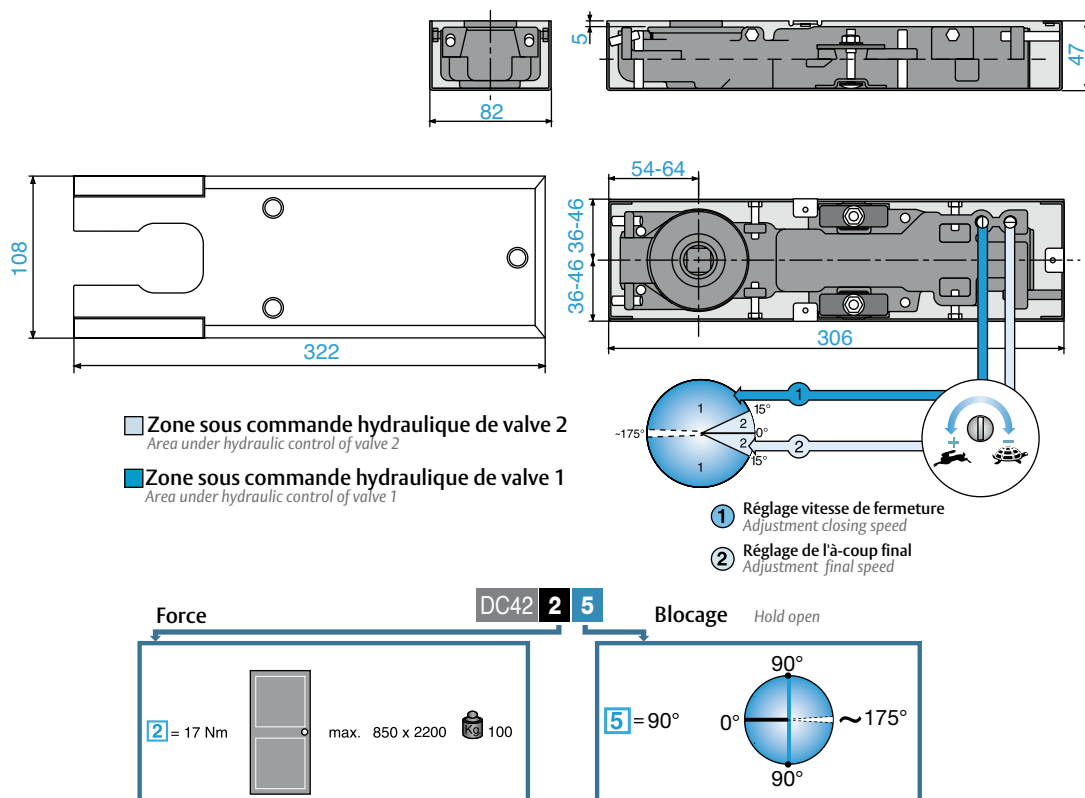

Références / References

DC422.5.99



Pivot de sol Force EN 2, sans axe, sans plaque, arrêt à 90°
Floor spring force 2 EN, no spindle, no cover plate, hold open at 90°

AC307

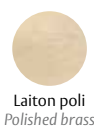

Références / References

Plaque de recouvrement 108 x 322 mm pour série DC420
Cover plate 108 x 322 mm for series DC420

AC307.00

AC307.15

Axes interchangeables
Interchangeable spindles

AC350.99

AC360.99

AC340.99

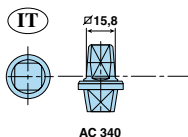
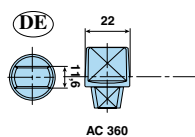
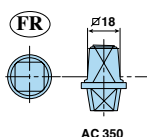

Pivots de sol et
ferme-portes
Floor springs and
door closers

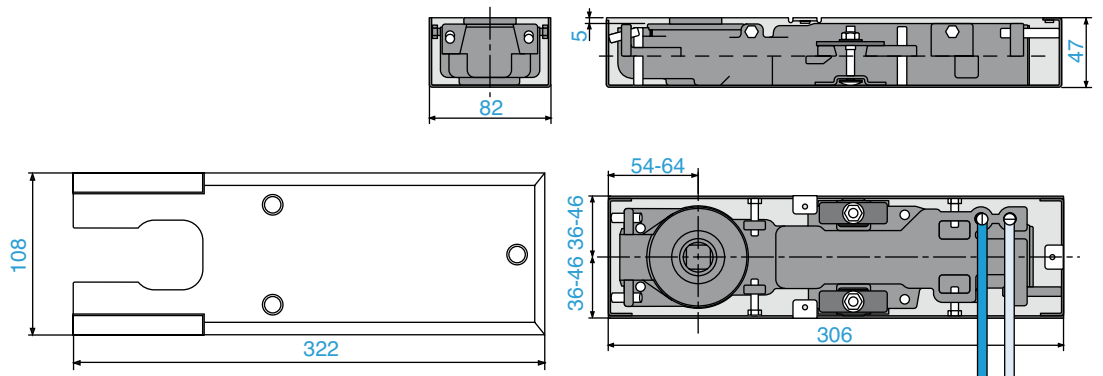

□ Zone sous commande hydraulique de valve 2
Area under hydraulic control of valve 2

■ Zone sous commande hydraulique de valve 1
Area under hydraulic control of valve 1

① Réglage vitesse de fermeture
Adjustment closing speed

② Réglage de l'à-coup final
Adjustment final movement



LES + PRODUITS
The + product

Etroit
Réglage vertical
Axe interchangeable

Slim
Vertical adjustment
Interchangeable
spindle

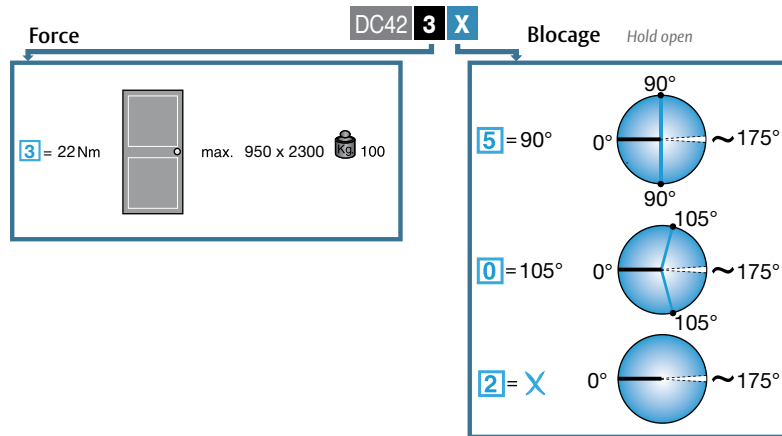

Références / References

DC423.5.99



Pivot de sol Force EN 3, sans axe, sans plaque, arrêt à 90°
Floor spring force 3 EN, no spindle, no cover plate, hold open at 90°

DC423.0.99

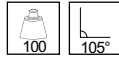

Pivot de sol Force EN 3, sans axe, sans plaque, arrêt à 105°
Floor spring force 3 EN, no spindle, no cover plate, hold open at 105°

DC423.2.99



Pivot de sol Force EN 3, sans axe, sans plaque, sans arrêt
Floor spring force 3 EN, no spindle, no cover plate, no hold open

AC307

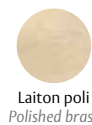

Laiton poli
Polished brass



Inox brossé
Brushed stainless steel

Références / References

Plaque de recouvrement 108 x 322 mm pour série DC420
Cover plate 108 x 322 mm for series DC420

AC307.00

AC307.15

Axes interchangeables
Interchangeable spindles

AC350.99

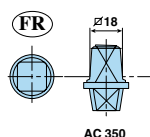

AC 350

AC360.99

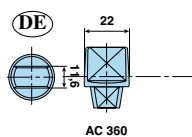

AC 360

AC340.99

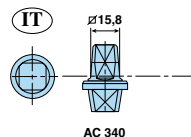

AC 340

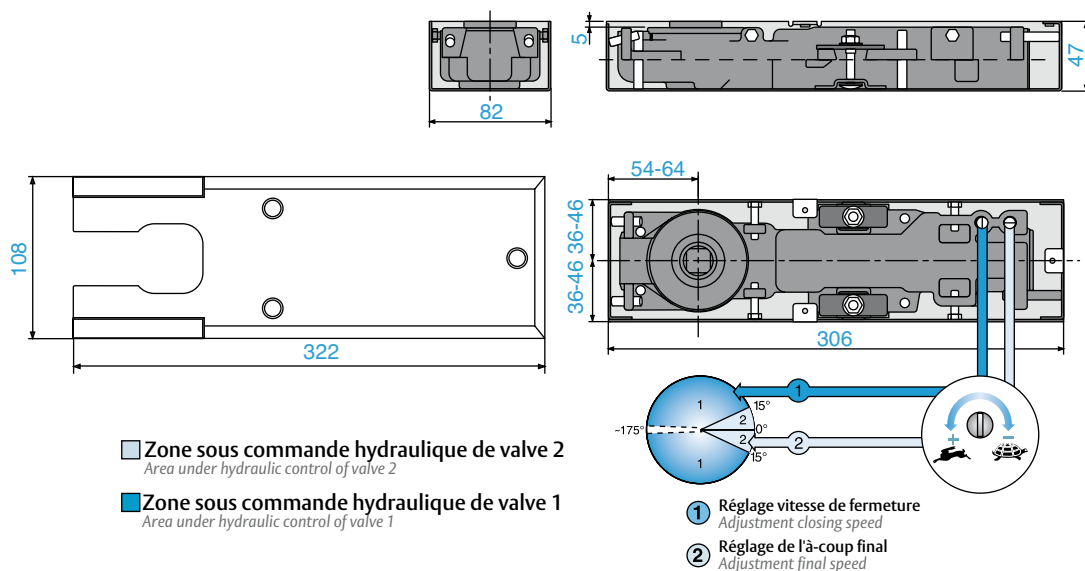

Zone sous commande hydraulique de valve 2
Area under hydraulic control of valve 2

Zone sous commande hydraulique de valve 1
Area under hydraulic control of valve 1

- ① Réglage vitesse de fermeture
Adjustment closing speed
- ② Réglage de l'à-coup final
Adjustment final speed

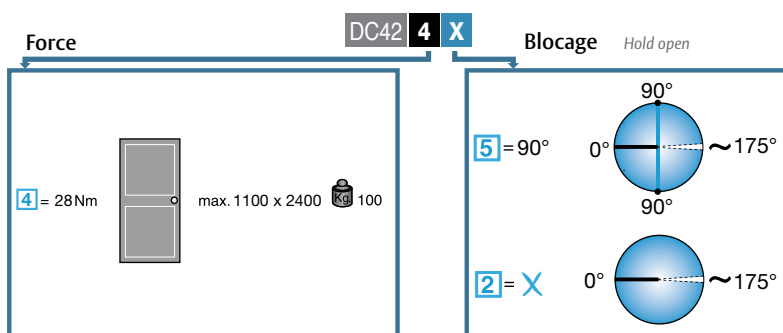

Références / References

DC424.5.99

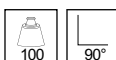

Pivot de sol Force EN 4, sans axe, sans plaque, arrêt à 90°
Floor spring force 4 EN, no spindle, no cover plate, hold open at 90°

DC424.2.99

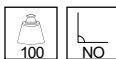

Pivot de sol Force EN 4, sans axe, sans plaque, sans arrêt
Floor spring force 4 EN, no spindle, no cover plate, no hold open

AC307

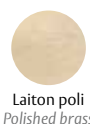

Laiton poli
Polished brass



Inox brossé
Brushed stainless steel

Références / References

Plaque de recouvrement 108 x 322 mm pour série DC420
Cover plate 108 x 322 mm for series DC420

AC307.00

AC307.15

Axes interchangeables
Interchangeable spindles

AC350.99

AC360.99

AC340.99

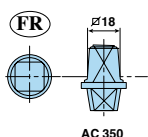

AC 350

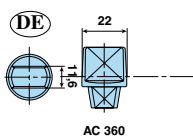

AC 360

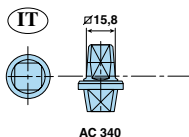

AC 340

Pivots de sol série DC450

Floor springs DC450 series

Caractéristiques techniques

- Force EN 3 pour portes ≤ 950 mm et force EN4 pour portes ≤ 1100 mm.
- Recommandé pour les portes jusqu'à 120 kg.
- Axe amovible : carré français, rectangulaire allemand, carré italien
- Arrêt à 90°, 105° et sans arrêt
- Pour porte droite, gauche et double actions.
- Pour porte intérieure ou extérieure
- Boite de scellement profondeur 40 mm, adapté aux dalles minces.
- Corps en fonte pour garantir la longévité.
- Ajustement du corps dans le boîtier de scellement.
- Contrôle hydraulique sur 130° dans le 2 sens.
- Vitesse de fermeture et à-coup final réglables
- Plaque de recouvrement et cravate en inox
- Tous les modèles ont la certification EN1154.

La version Force EN 3-4, sans blocage, est conforme à la norme CE.

Pour commander un pivot de sol complet, il est nécessaire d'utiliser 3 références produit :

- 1 réf DC45*.*99 Corps du pivot + boîte de scellement
- 1 réf AC619.15 Plaque de recouvrement
- 1 réf AC3*0.99 Axe amovible

Technical features

- Fix Size EN3 for doors ≤ 950 mm and EN4 for doors ≤ 1100 mm.
- Max door weight 120 kg.
- Interchangeable spindles French square, German rectangular, Italian square.
- Hold open at 90°, 105° or no hold open
- Universal for right, left and double action doors.
- For internal and external doors.
- Cement box only 40 mm height, to suit thin slabs.
- Cast iron body to ensure strong durability.
- Adjustment in all direction within the cement box.
- Hydraulic control over 130° in both swings.
- Closing speed adjustment and latching speed adjustment.
- Cover plate and eyelet in polished and satin stainless steel for a consistent aesthetic appeal.
- All models have certification EN1154.

Version force 3-4, without hold open, have CE conformity

To order a complete floor spring, it is necessary to use 3 products reference:

- 1 ref DC45*.*99 Body pivot with its sealing box
- 1 ref AC619.15 cover plate
- 1 ref AC3*0.99 Interchangeable spindles



LES + PRODUITS

Only 40 mm deep

Interchangeable
Spindle

Cover plate and
eyelet in stainless
steel

Seulement 40 mm
de profondeur

Axe amovible

Plaque de
recouvrement
et cravate en inox



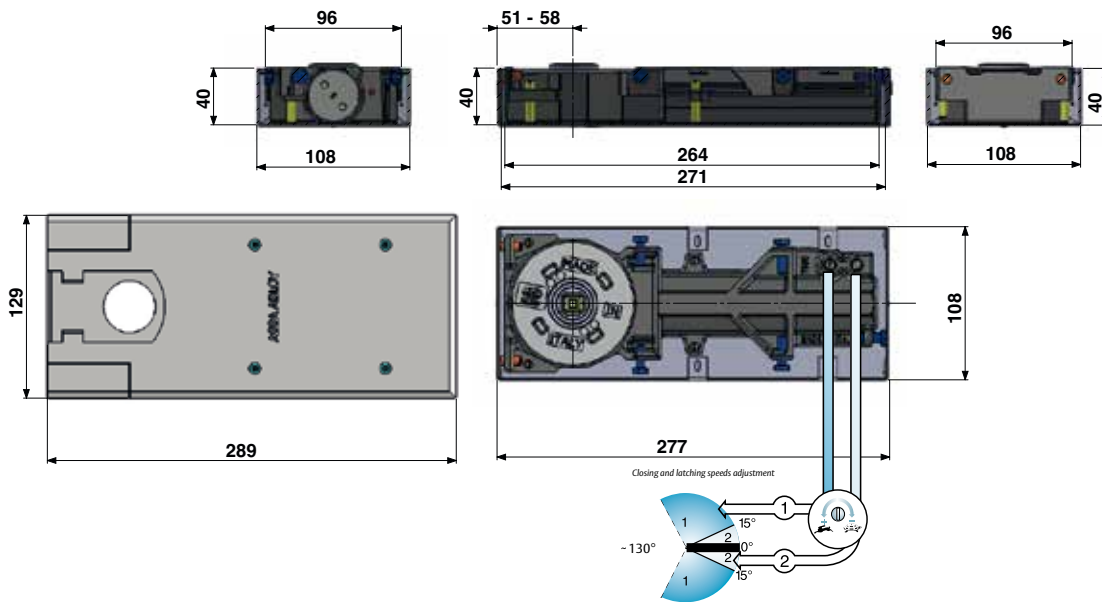

Forza EN
EN Size

DC. 45XX.99

3 = 22 Nm	max. 950 x 2300	120
4 = 28 Nm	max. 1100 x 2400	120

5 = 90°	
0 = 105°	
2 = X	

Références / References

- DC453.5.99** Pivot de sol Force EN 3, sans axe, sans plaque, arrêt à 90°
Floor spring force 3 EN, no spindle, no cover plate, hold open at 90°
- DC453.0.99** Pivot de sol Force EN 3, sans axe, sans plaque, arrêt 105°
Floor spring force 3 EN, no spindle, no cover plate, hold open at 105°
- DC453.2.99** Pivot de sol Force EN 3, sans axe, sans plaque, sans arrêt
Floor spring force 3 EN, no spindle, no cover plate, no hold open

AC619.15



Références / References

Plaque de recouvrement 129 x 289 mm pour série DC450
Cover plate 129 x 289 mm for series DC450

AC619.15

Axes interchangeables
Interchangeable spindles

AC350.99	AC360.99	AC340.99
FR $\varnothing 18$	DE $\varnothing 22$	IT $\varnothing 15,8$
AC 350	AC 360	AC 340

Pivot de sol et
ferme-portes
Floor springs and
door closers

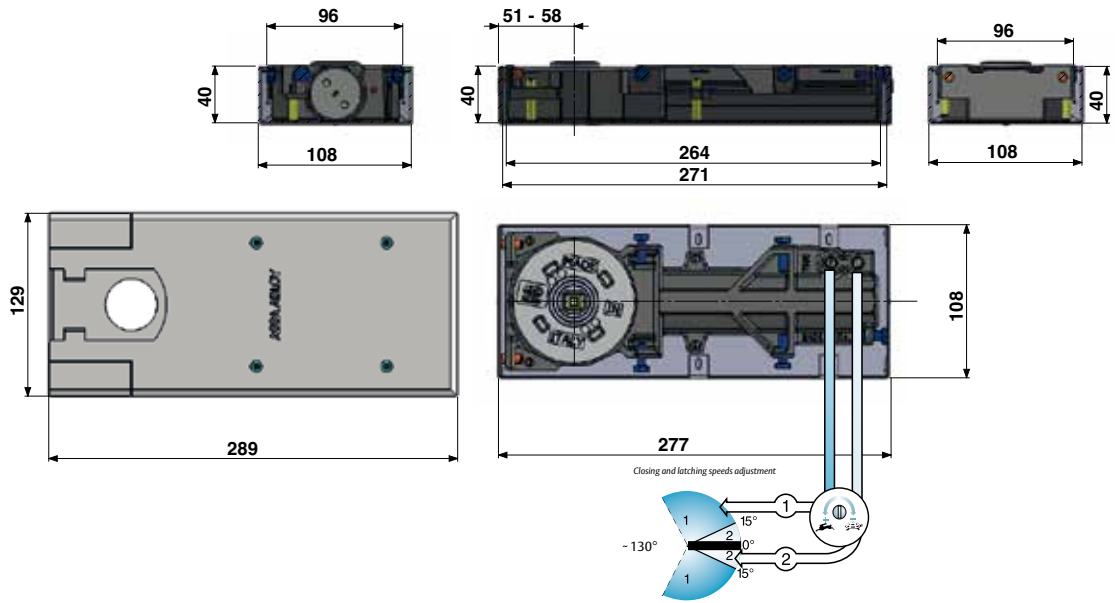

LES + PRODUITS

Only 40 mm deep
Interchangeable
Spindle

Cover plate and
eyelet in stainless
steel

Seulement 40 mm
de profondeur

Axe amovible

Plaque de
recouvrement
et cravate en inox

Forza EN
EN Size

DC. **45XX**.99

3 = 22 Nm		max. 950 x 2300	120
4 = 28 Nm		max. 1100 x 2400	120

5 = 90°	
0 = 105°	
2 = X	

Références / References

DC454.5.99



Pivot de sol Force EN 4, sans axe, sans plaque, arrêt à 90°
Floor spring force 4 EN, no spindle, no cover plate, hold open at 90°

DC454.0.99



Pivot de sol Force EN 4, sans axe, sans plaque, arrêt 105°
Floor spring force 4 EN, no spindle, no cover plate, hold open at 105°

DC454.2.99

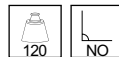

Pivot de sol Force EN 4, sans axe, sans plaque, sans arrêt
Floor spring force 4 EN, no spindle, no cover plate, no hold open

AC619.15



Références / References

Plaque de recouvrement 129 x 289 mm pour série DC450
Cover plate 129 x 289 mm for series DC450

AC619.15

Axes interchangeables
Interchangeable spindles

AC350.99

AC360.99

AC340.99

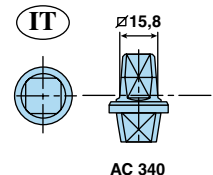
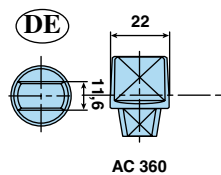
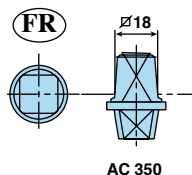



Pivots de sol et
ferme-portes
Floor springs and
door closers

Pivots de sol série DC477

Floor springs DC477 series

Caractéristiques techniques

- Force ajustable de 2 à 4 EN (14-28 Nm)
- Recommandé pour les portes jusqu'à 170 kg
- Axe amovible : carré français, rectangulaire allemand, carré italien
- Arrêt à 90°, 105° et sans arrêt
- Contrôle hydraulique sur 150° dans les deux sens
- Vitesse de fermeture et à-coup final réglables
- Frein à l'ouverture
- Grande amplitude d'ajustement du corps dans le boîtier de scellement : Largeur 8 mm
Longueur 10 mm
Hauteur 9 mm
- Corps en fonte et boîtier zingué

Tous les modèles ont la certification EN1154.
La version Force EN 3-4, sans blocage, est conforme à la norme CE.

Technical features

- Adjustable force EN 2-4 (14-28 Nm).
- Recommended for doors up to 170 kg.
- Variety of available spindles : French square, German rectangular, Italian square
- Hold open at 90°, 105° or no hold open
- Hydraulic control over 150° in both directions
- Two independent thermostatic valves for precise adjustment of general closing speed, final latch or final damping
- Back check effect
- Large range of adjustment body setting in the cementing box : Width 8 mm
Length 10 mm
Height 9 mm
- Cast iron body and cementing box in hot zinc plated steel

All models have quality certification EN1154.
Versions force EN3-4, without Hold Open, have CE conformity.

LES + PRODUITS

The + product

Force réglable

Axe amovible

Frein à l'ouverture

Adjustable force

Interchangeable spindle

Mechanical back check



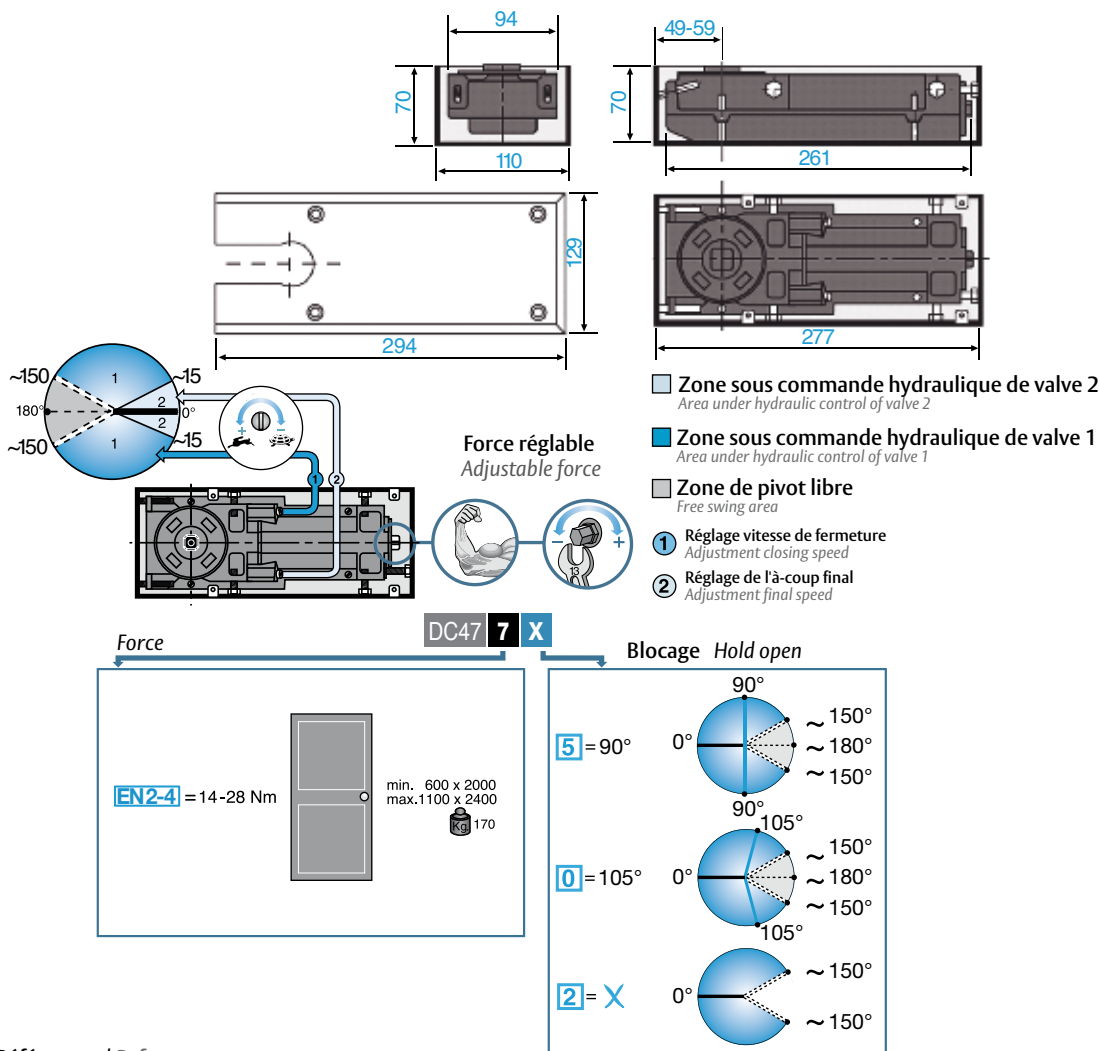

Références / References

DC477.5.99		Pivot de sol Force réglable EN 2 à 4, sans axe, sans plaque, arrêt à 90° Floor spring adjustable force 2 - 4 EN, no spindle, no cover plate, hold open at 90°
DC477.0.99		Pivot de sol Force réglable EN 2 à 4, sans axe, sans plaque, arrêt à 105° Floor spring adjustable force 2 - 4 EN, no spindle, no cover plate, hold open at 105°
DC477.2.99		Pivot de sol Force réglable EN 2 à 4, sans axe, sans plaque, sans arrêt Floor spring adjustable force 2 - 4 EN, no spindle, no cover plate, no hold open

AC534



Références / References

Plaque de recouvrement 129 x 294 mm pour série DC477
Cover plate 129 x 294 mm for series DC477

Laiton poli Polished brass	Inox brossé Brushed stainless steel
AC534.00	AC534.15

Axes interchangeables
Interchangeable spindles

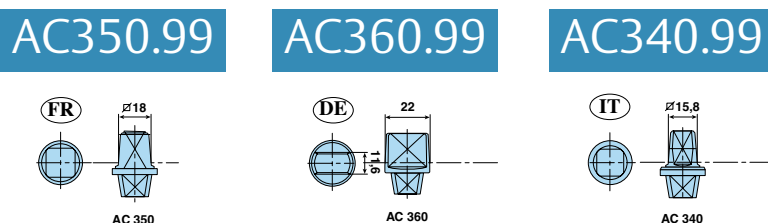

Pivots de sol et
ferme-portes
Floor springs and
door closers

Pivots de sol série DC475

Floor springs DC475 series



LES + PRODUITS

The + product

Force réglable

Axe amovible

Frein à l'ouverture

Pour porte lourdes

Adjustable force

Interchangeable
spindle

Mechanical back check

For heavy doors

Caractéristiques techniques

- Force ajustable de 3 à 6 EN (24-60 Nm)
- Recommandé pour les portes larges ou lourdes jusqu'à 300 kg
- Axe amovible : carré français, rectangulaire allemand, carré italien
- Arrêt à 90°, 105° et sans arrêt
- Contrôle hydraulique sur 175° dans les deux sens
- Vitesse de fermeture et à-coup final réglables
- Frein à l'ouverture
- Grande amplitude d'ajustement du corps dans le boîtier de scellement : Largeur 6 mm
Longueur 5 mm
Hauteur 9 mm
- Corps en fonte et boîtier zingué

Tous les modèles ont la certification EN1154.
La version sans arrêt est conforme à la norme CE.

Technical features

- Adjustable force EN 3-6 (24-60 Nm)
- Recommended for large and very heavy doors up to 300 kg
- Variety of available spindles : French square, German rectangular, Italian square
- Hold open at 90°, 105° or no hold open
- Hydraulic control over 175° in both directions
- Two independent thermostatic valves for precise adjustment of general closing speed, final latch or final damping
- Back check effect
- Large range of adjustment body setting in the cementing box : Width 6 mm
Length 5 mm
Height 9 mm
- Cast iron body and cementing box in hot zinc plated steel

All models have quality certification EN1154.
Versions without hold open have CE conformity.



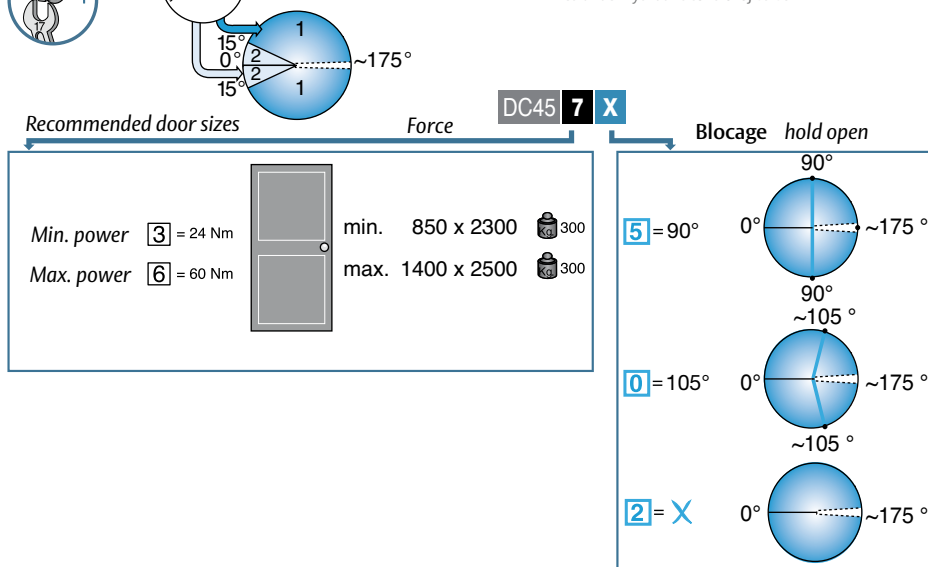
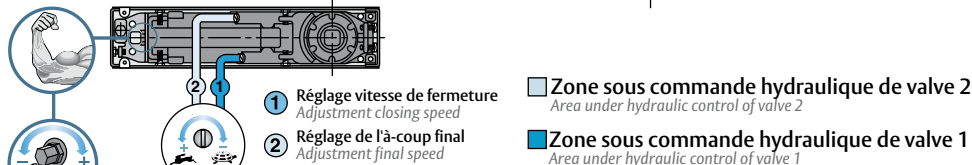
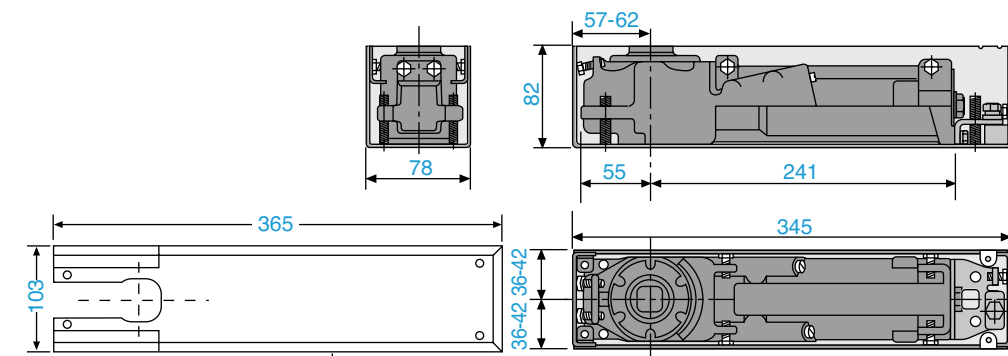

Références / References

DC475.5.99			Pivot de sol Force réglable EN 3 à 6, sans axe, sans plaque, arrêt à 90° Floor spring adjustable force 3 – 6 EN, no spindle, no cover plate, hold open at 90°
DC475.0.99			Pivot de sol Force réglable EN 3 à 6, sans axe, sans plaque, arrêt à 105° Floor spring adjustable force 3 – 6 EN, no spindle, no cover plate, hold open at 105°
DC475.2.99			Pivot de sol Force réglable EN 3 à 6, sans axe, sans plaque, sans arrêt Floor spring adjustable force 3 – 6 EN, no spindle, no cover plate, no hold open

AC269



Références / References

Plaque de recouvrement 103 X 365 mm pour série DC475
Cover plate 103 x 365 mm for series DC475 **AC269.15**

Axes interchangeables
Interchangeable spindles

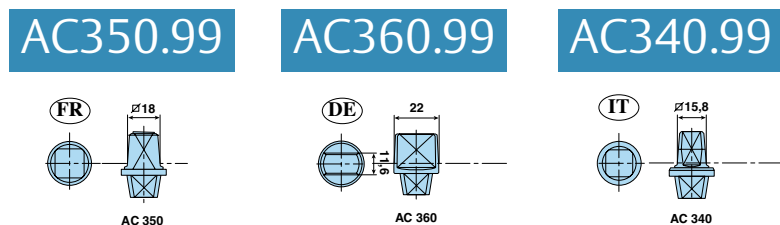

Pivots de sol et
ferme-portes
Floor springs and
door closers

AC612.99

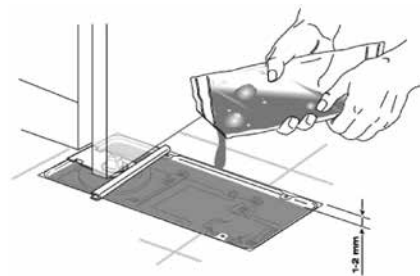

Gel de remplissage pour boîtier encastré de pivot de sol
Sealing Compound for floor concealed closers

- Chaque boîte contient 2 sachets 500 cc de gel
Quantité nécessaire selon le pivot de sol :
 - 7130 : 1 sachet (500 cc)
 - DC420 : 1 sachet (500 cc)
 - DC460 : 1 sachet (500 cc)
 - DC477 : 2 sachets (1000 cc)
 - DC475 : 2 sachets (1000 cc)
- Réglage toujours possible après utilisation

- Each box contains 2 packs of 500 cc of filler
Quantity needed according to floor spring type :
 - 7130 : 1 pack (500 cc)
 - DC420 : 1 pack (500 cc)
 - DC460 : 1 pack (500 cc)
 - DC477 : 2 packs (1000 cc)
 - DC475 : 2 packs (1000 cc)
- Adjustment always possible after filling



LES + PRODUITS
The + product

Sans encoche
Force réglable

No notch
Adjustable force

Axes interchangeables Interchangeable spindles

F

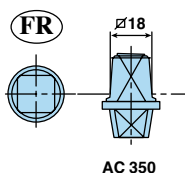

D

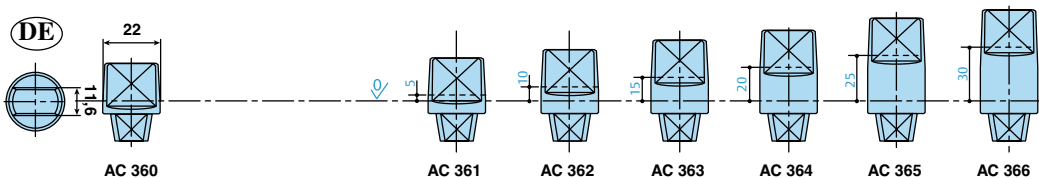

I

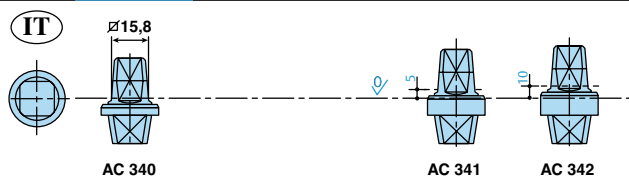

Accessoires pour porte bois et métal

Accessories for wooden and steel doors

Pivots de sol et
ferme-portes
Floor springs and
door closers

AC8.10.0

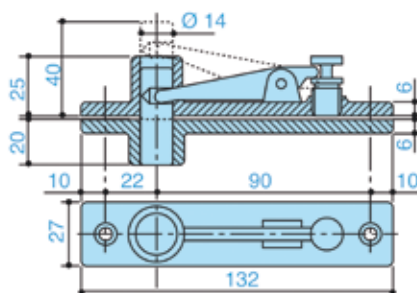

Références / References



Pivot haut double action.
Double acting top pivot.

AC384.99.0

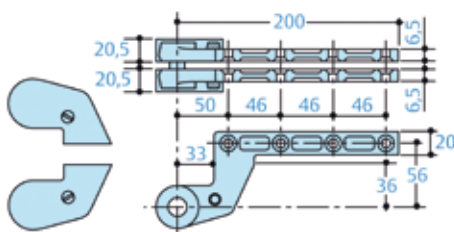

Références / References



Pivot supérieur acier pour porte droite ou gauche simple action, déporté de 36 mm.
Right and left top arm in steel for single acting doors, 36 mm offset.

AC393.90.0

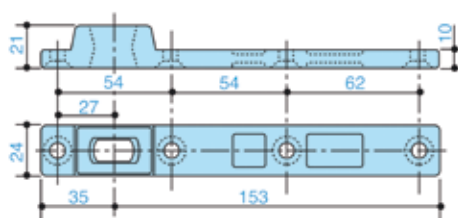

Références / References



Bras inférieur acier pour porte double action, insert rectangulaire allemand.
Bottom arm in steel for double action door, German rectangular insert.

AC392.99.0

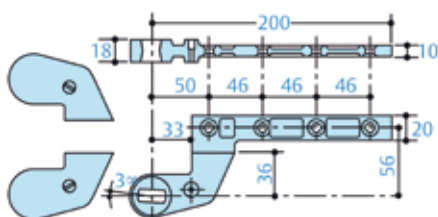

Références / References



Bras inférieur acier pour porte droite ou gauche simple action, déporté de 36 mm. Insert rectangulaire allemand.
Right and left bottom arm in steel for simple acting doors 36 mm offset. German rectangular insert.





Boutons et poignées de porte
Door knobs and handles

ASSA ABLOY

Boutons et poignées de porte
Door knobs and handles

AMT140192.15

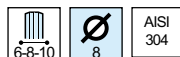
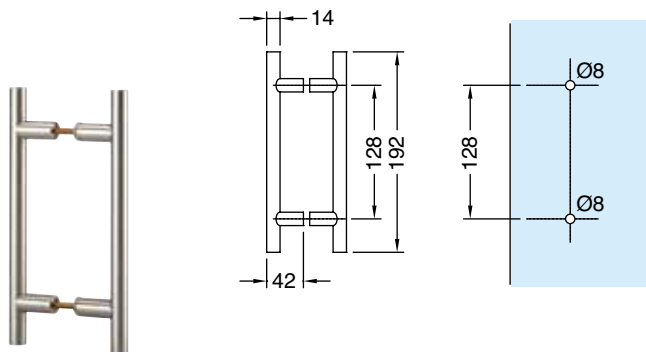

Paire de poignées inox brossé Ø 14 mm entraxe 128 mm, longueur totale 192 mm
Pair of stainless steel handles Ø 14 mm, centre distance 128 mm, total length 192 mm

LES + PRODUITS

The + product

Design

Grande qualité de finitions

Elegant design

High quality finishes

AMT200300.15

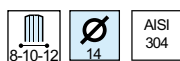
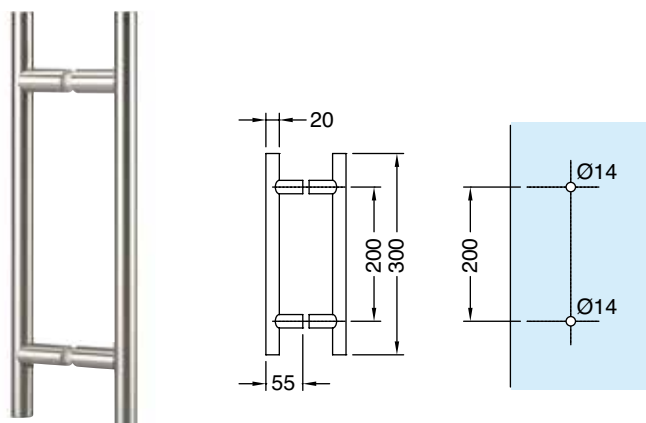

Paire de poignées inox brossé Ø 20 mm entraxe 200 mm, longueur totale 300 mm
Pair of stainless steel handles Ø 20 mm, centre distance 200 mm, total length 300 mm

AMT200500.15

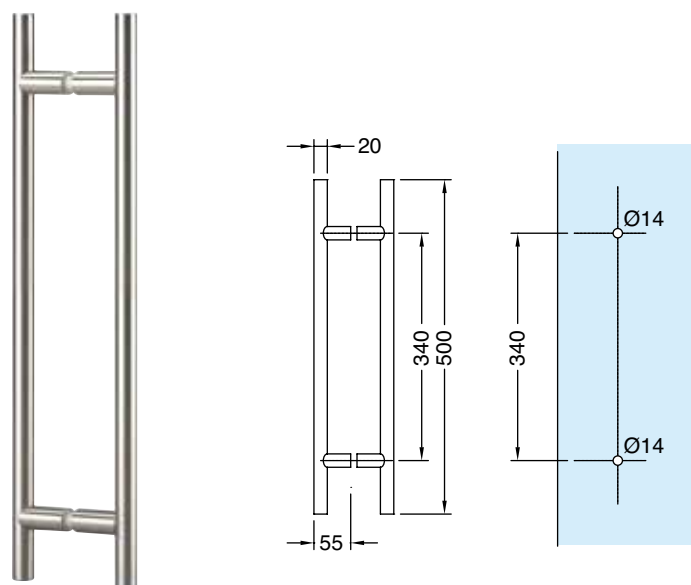

Paire de poignées inox brossé Ø 20 mm entraxe 340 mm, longueur totale 500 mm
Pair of stainless steel handles Ø 20 mm, centre distance 340 mm, total length 500 mm

AMT200700.15

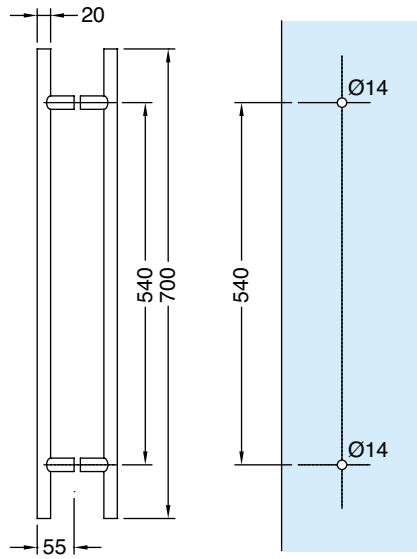

Boutons et poignées
de porte
*Door knobs
and handles*



Paire de poignées inox brossé Ø 20 mm entraxe 540 mm, longueur totale 700 mm
Pair of stainless steel handles Ø 20 mm, centre distance 540 mm, total length 700 mm

AMT201200.15

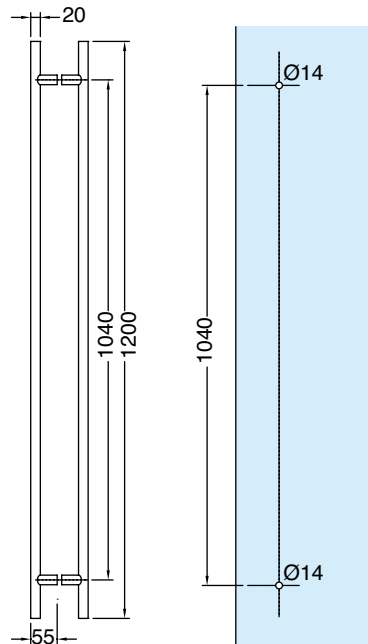

Paire de poignées inox brossé Ø 20 mm entraxe 1040 mm, longueur totale 1200 mm
Pair of stainless steel handles Ø 20 mm, centre distance 1040 mm, total length 1200 mm

Boutons et poignées de porte
Door knobs and handles

AMT300300.15

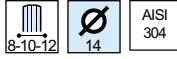
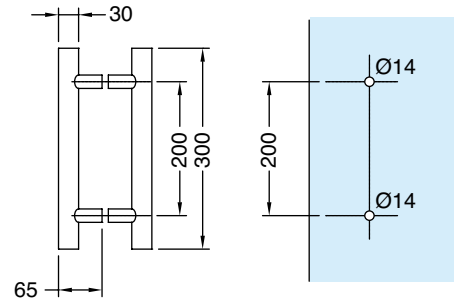

Paire de poignées inox brossé Ø 30 mm entraxe 200 mm, longueur totale 300 mm
Pair of stainless steel handles Ø 30 mm, centre distance 200 mm, total length 300 mm



AMT300500.15

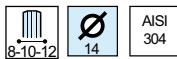
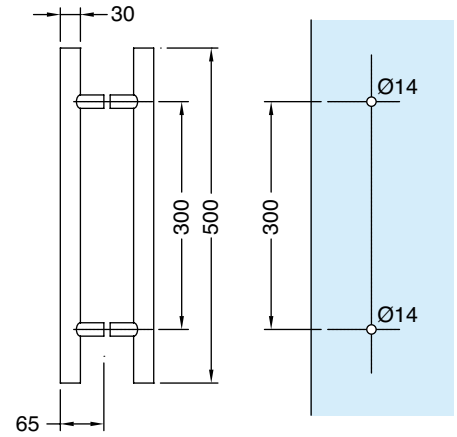

Paire de poignées inox brossé Ø 30 mm entraxe 300 mm, longueur totale 500 mm
Pair of stainless steel handles Ø 30 mm, centre distance 300 mm, total length 500 mm

C600PG22

C600PG30

C601PG22

C601PG30

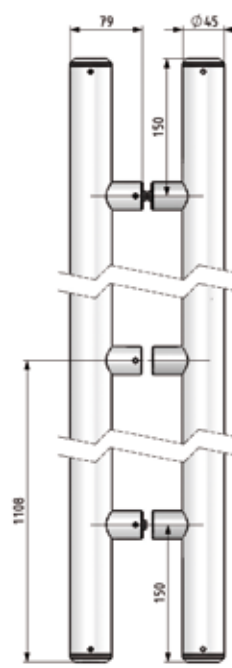
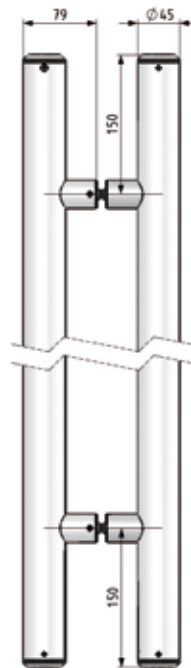
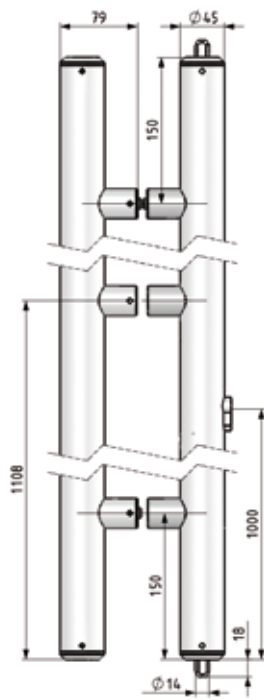
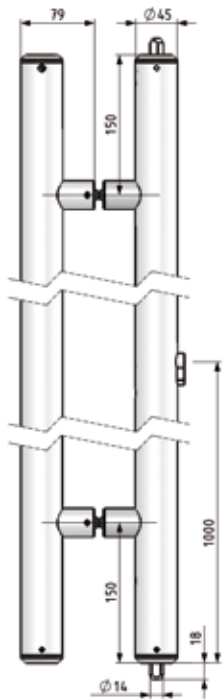

Références / References

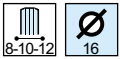

Poignées Ø 45 mm, avec serrure 2 points d'un côté, hauteur maxi : 2200 mm
Handle 45 Ø mm with 2 point lock on one side, height max : 2200 mm

Poignées Ø 45 mm, avec serrure 2 points d'un côté, hauteur entre 2200 mm et 3000 mm maxi
Handle 45 Ø mm with 2 point lock on one side, height max between 2200 mm and 3000 mm

Poignées Ø 45 mm, hauteur maxi : 2200 mm
Handle 45 Ø mm height max 2200 mm

Poignées Ø 45 mm, hauteur entre 2200 mm et 3000 mm maxi
Handle 45 Ø mm, height max between 2200 mm and 3000 mm



C600PG22.15

C600PG30.15

C601PG22.15

C601PG30.15

Boutons et poignées
de porte
Door knobs
and handles



LES + PRODUITS
The + product

Esthétique
Double fonction :
tirage et verrouillage
Robustesse
Porte grande
hauteur

Attractive design
Double function :
pull and lock
Resistant
For high doors



Boutons et poignées de porte
Door knobs and handles

SL27

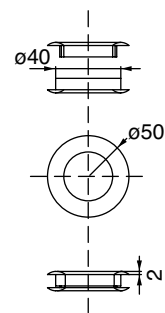

Références / References



Anneau de tirage pour coulissant
Ring pull for sliding doors

SL27.30

SL27.31



AMGMODEL/**.15

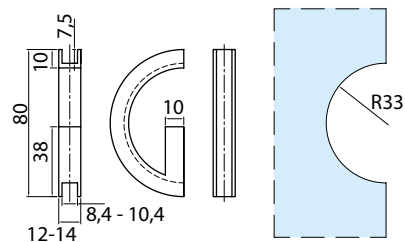

Inox brossé
Brushed stainless steel

Poignée 'G' pour porte coulissante
Double round head knob 50 mm Ø

AMGMODEL/8.15



Poignée 'G' pour porte coulissante
Double round head knob 50 mm Ø

AMGMODEL/10.15

1653.**.0

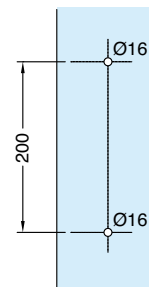
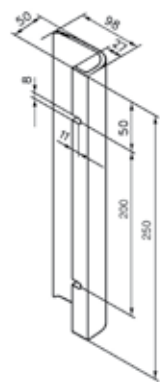

Aluminium anodisé Argent satiné
Satin anodised alu. silver

1653.10.0

Références / References



Paire de poignées aileron entraxe 200 mm lg 250 mm
Pair of flat handles centre distance 200 mm, length 250 mm

- Pose verticale ou horizontale
- Livré avec accessoires de pose pour porte en verre ou aluminium
- Vertical or horizontal fixing
- Supplied with accessories for fixing on glass or aluminium doors

1654.**.0

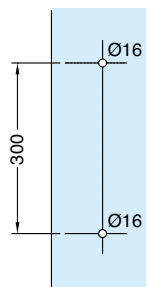
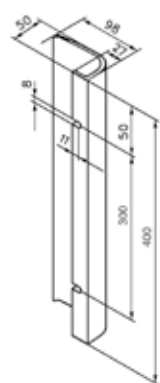

Aluminium anodisé Argent satiné
Satin anodised alu. silver

1654.10.0

Références / References



Paire de poignées aileron entraxe 300 mm, lg 400 mm
Pair of flat handles centre distance 300 mm, length 400 mm

- Pose verticale ou horizontale
- Livré avec accessoires de pose pour porte en verre ou aluminium
- Vertical or horizontal fixing
- Supplied with accessories for fixing on glass or aluminium doors

2827.**.0

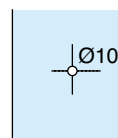
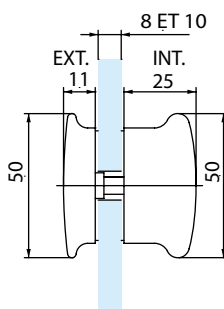

Chromé brillant
Bright chromium



Chromé mat
Matt chromium

Références / References



Bouton double extra plat Ø 50 mm ELOA
Pair of knob 50 mm Ø ELOA

2827.30.0

2827.31.0

Boutons et poignées de porte
Door knobs and handles

Boutons et poignées de porte
Door knobs and handles

2927.**.0

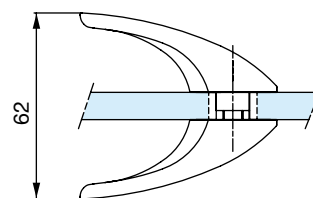
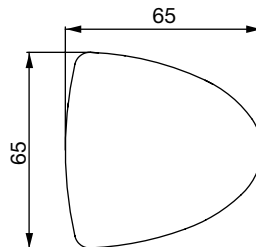

Références / References



Paire de poignées aileron PAREO
Pair of handles PAREO



Chromé brillant
Bright chromium



Chromé mat
Matt chromium

2927.30.0

2927.31.0



3066.**.0

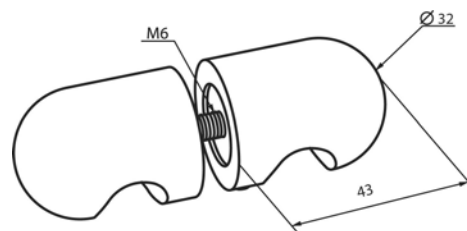

Références / References



Bouton double bombé Ø 32 mm
Pair of knobs 32 mm Ø



Chromé brillant
Bright chromium



Chromé mat
Matt chromium



Effet inox
Stainless steel effect

3066.30.0

3066.31.0

3066.35.0

3249.**.0

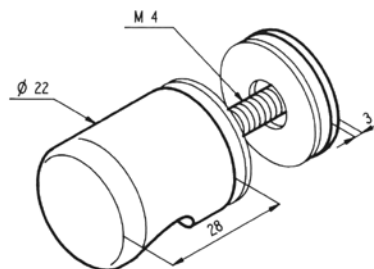

Références / References



Bouton simple bombé Ø 22 mm
22 mm Ø single round head knob



Laiton poli PVD
Polished brass PVD



Chromé brillant
Bright chromium



Chromé mat
Matt chromium



Effet inox
Stainless steel effect

3249.05.0

3249.30.0

3249.31.0

3249.35.0

3250.**.0

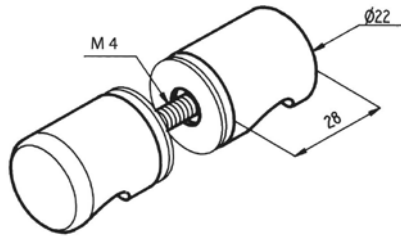

Références / References



Bouton double bombé Ø 22 mm
Pair of knobs 22 mm Ø



Chromé brillant
Bright chromium

3250.30.0



Chromé mat
Matt chromium

3250.31.0



Effet inox
Stainless steel effect

3250.35.0

3251.**.0

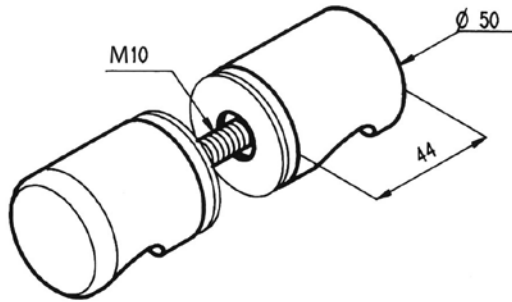

Références / References



Bouton double bombé Ø 50 mm
Pair of knobs 50 mm Ø



Laiton poli PVD
Polished brass PVD

3251.05.0



Chromé brillant
Bright chromium

3251.30.0



Chromé mat
Matt chromium

3251.31.0



Effet inox
Stainless steel effect

3251.35.0

Boutons et poi-
gnées
de porte
Door knobs
and handles

Boutons et poignées de porte
Door knobs and handles

3259.**.0

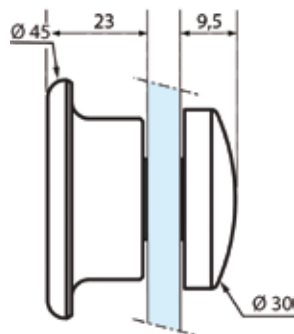

Références / References



Bouton simple bombé Ø 45 mm
45 mm Ø single knob

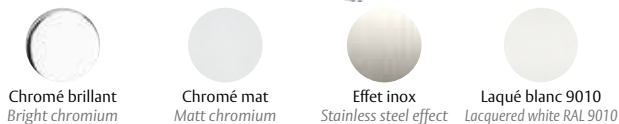

3259.30.0 3259.31.0 3259.35.0 3259.51.0

3266.**.0

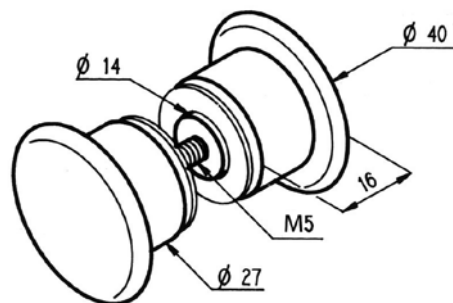

Références / References



Bouton double épaulé Ø 40 mm
Pair of knobs 40 mm Ø



3266.05.0 3266.30.0 3266.31.0 3266.35.0 3266.51.0

3267.**.0

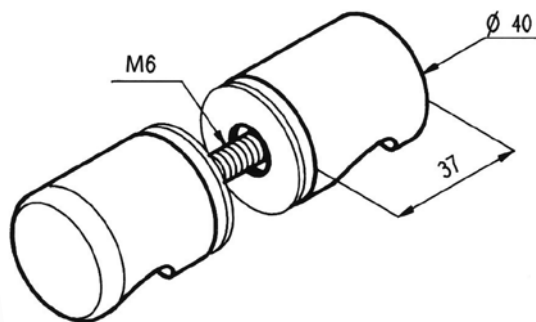

Références / References



Bouton double bombé Ø 40 mm
Pair of knobs 40 mm Ø



3267.05.0 3267.30.0 3267.31.0 3267.35.0 3267.51.0

3290.**.0

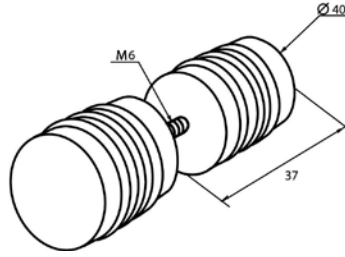

Boutons et poignées de porte
Door knobs and handles

Références / References



Bouton double bombé anti-dérapant Ø 40 mm
Pair of double anti-slip knobs 40 mm Ø



Chromé brillant
Bright chromium



Chromé mat
Matt chromium

3290.30.0

3290.31.0

3666.**.0

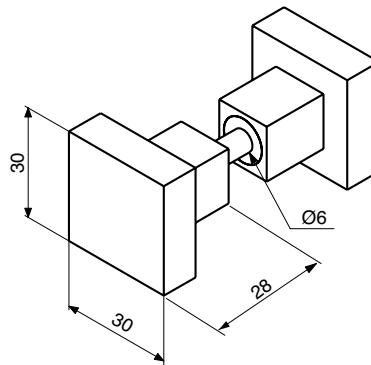

Références / References

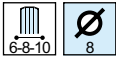

Bouton double carré 30 x 30 mm
Pair of square knob 30 x 30 mm



Chromé brillant
Bright chromium



Chromé mat
Matt chromium

3666.30.0

3666.31.0



Boutons et poignées de porte
Door knobs and handles

5630.**.7

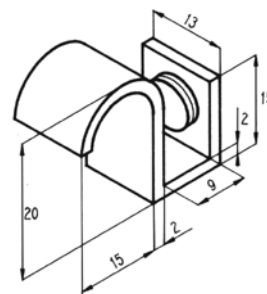

Références / References



5 Pinces à tirette
5 pull catch



Chromé brillant
Bright chromium



Chromé mat
Matt chromium

5630.30.7

5630.31.7



5631.99.2

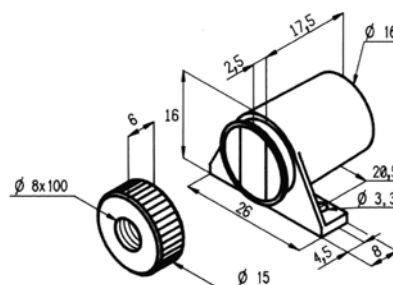

5 aimants et rondelles pour tirette 5630.**.7
5 magnet and washer for pull catch clip series 5630.**.7

5723.**.0

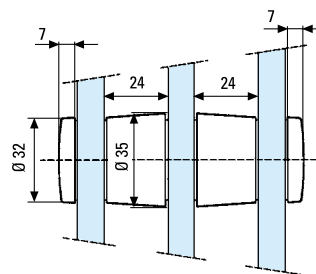

Références / References



Axe pour fixation poignée verre
Axis for fixing glass handle



Chromé brillant
Bright chromium



Chromé mat
Matt chromium

5723.30.0

5723.31.0



Systèmes pour Douches
Shower systems

ASSA ABLOY

Slice

Caractéristiques techniques

- Pour verre trempé de 8 ou 10 mm (non fourni)
- Poids maxi par porte : 60 kg
- Entre deux murs : largeur maxi 3000 mm
- Sans encoche
- Pour verre trempé de 8 et 10 mm (non fourni)
- Fixation au mur ou au plafond
- Rail : aluminium anodisé ou laqué RAL

Système ultra compact, avec dimensions réduites (50X60 mm), le SLICE s'intègre avec discrétion à tous types d'intérieurs :

- Roulement à billes pour minimiser le bruit,
- Amortisseurs hydrauliques en fin de course,
- Guide au sol avec patins.

Technical features

- For toughened glass doors 8 or 10 mm (not supplied)
- Maximum door weight : 60 kg
- Between two walls : maximum width 3000 mm
- No notch required
- For 8 and 10 mm thick toughened glass (not supplied)
- Wall or ceiling installation
- Rail : Anodised aluminium or RAL lacquered finish

Ultra compact system, with its slim line measurements (50X60 mm), SLICE fits with discretion into all types of interiors :

- Trolleys to decrease noise,
- Hydraulic shock absorbers,
- Special floor guide.

Références / References



Kits complets / Complete Kits



Alu. anodisé argent brossé
Brushed anodised alu. silver



Alu. anodisé ANINOX
Brushed anodised alu.



Laqué Blanc
Lacquered white

Système pour porte simple coulissante, rail lg 2500 mm
System for single sliding door, rail length 2500 mm

KSLD60M1.12

KSLD60M1.36

KSLD60M1.51

Références / References



Anneau de tirage
Ring pull



Chromé brillant
Bright chromium



Chromé mat
Matt chromium

SL27.30

SL27.31

Ce kit comprend

KSLD60M1.**

- Un rail avec cache rail lg 2500 mm, 2 chariots avec pinces, 2 butées, 2 embouts, 1 guide au sol, 1 joint bas de porte, 1 joint bourrelet, 1 joint à lèvres latéral masse réduite vertical et 1 bouton double 2827.

This kit includes

KSLD60M1.**

- One rail and cover length 2500 mm, 2 glass clamping trolleys, 2 stops, 2 end covers, 1 floor guide, sealing strip for bottom of door, 1 superslim seal with lateral lip and lip acompressor and a 2827 double knob.

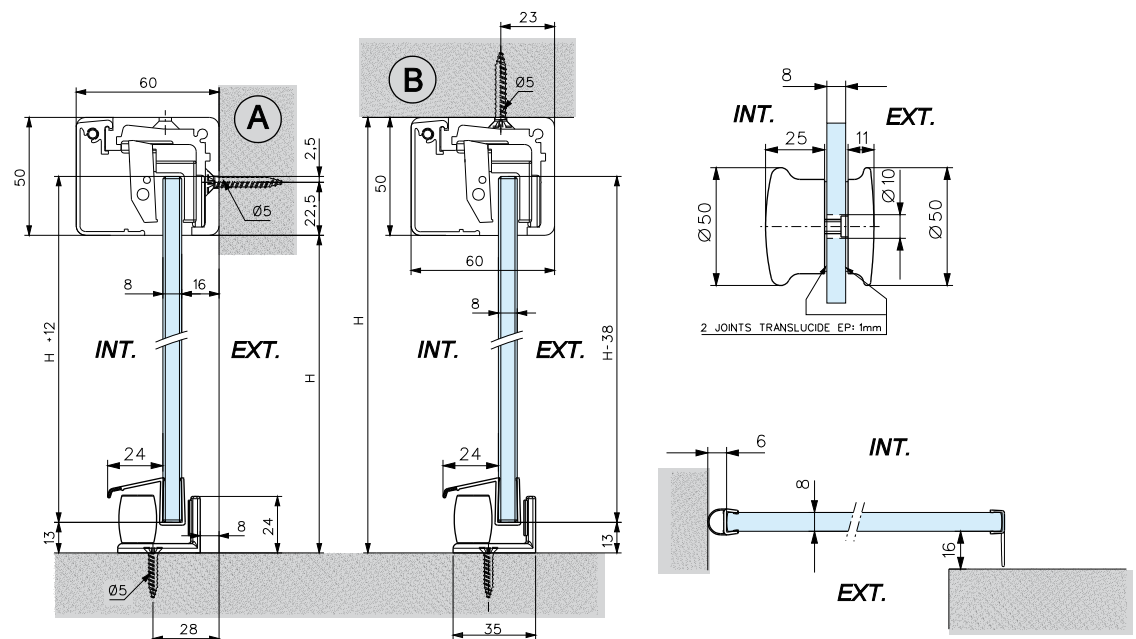

Systèmes
coulissants
pour douches
*Sliding shower
system*



Systèmes
couissants
pour douches
*Sliding shower
system*

Eloa

Caractéristiques techniques

- Pour verre trempé de 8 mm (non fourni)
- Poids maxi par porte : 30 kg
- Entre deux murs : largeur maxi 2200 mm
- Lesens d'ouverture de la porte (droite ou gauche) doit être déterminé avant la réalisation des volumes

Technical features

- For toughened glass doors 8 mm (not supplied)
- Maximum door weight : 30 kg
- Between two walls : maximum width 2200 mm
- The opening direction (right or left) must be determined before glass manufacture

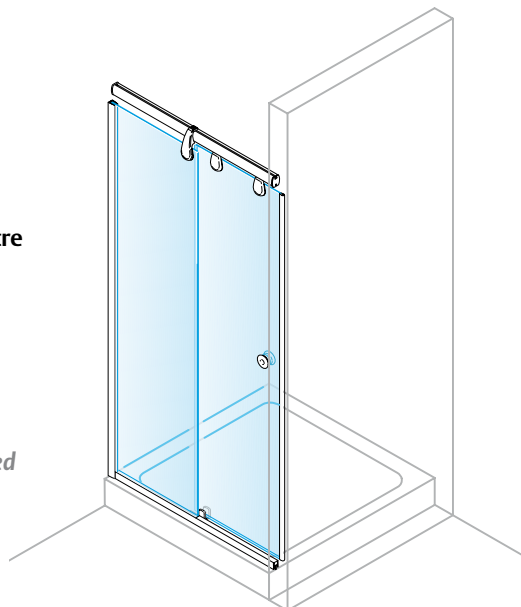

LES + PRODUITS

The + product

Design épuré
Entretien facile
Gain de place

Refined design
Easy cleaning
Space saving

2820.**.1

Références / References



Kits complets / Complete kits



Chromé brillant
Bright chromium



Chromé mat
Matt chromium

Système mur/mur 1 volume fixe et 1 ouvrant coulissant
System wall/wall 1 fixed panel and sliding panel

2820.30.1

2820.31.1

Largeur mur/mur Width wall/wall	Largeur de passage Passage width
1100	525
1000	475
900	425
800	375

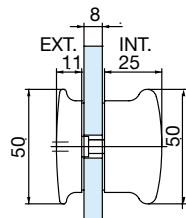
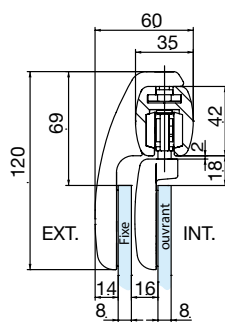
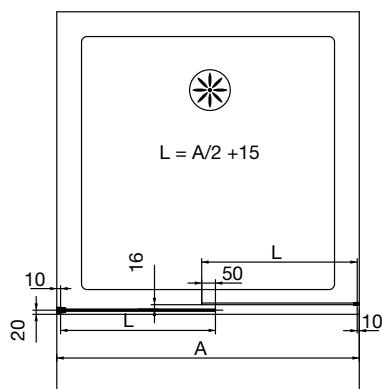

TROUS FRAISES
Holes milled

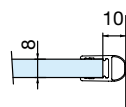
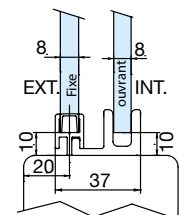
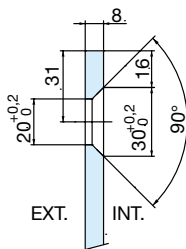

Attention : trous fraisés sur la face intérieure de la douche
Caution : holes milled on the inside face of the shower

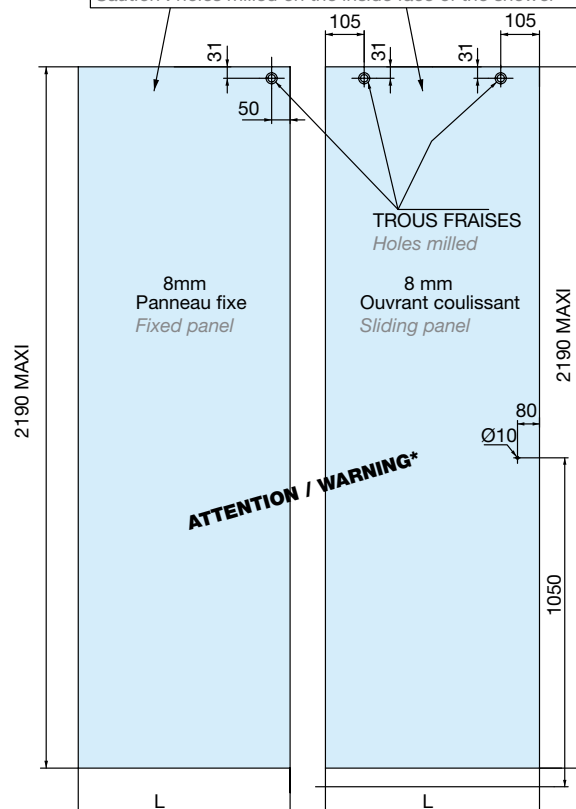

* Plan valable uniquement pour une porte à droite,
pour porte à gauche, inverser le sens des fraisures
Drawing is valid only for doors on the right hand side,
for the left hand side, reverse the direction of countersinking

Systèmes
coulissants
pour douches
*Sliding shower
system*



Systèmes
couissants
pour douches
*Sliding shower
system*

Eloa

Caractéristiques techniques

- Pour verre trempé de 8 mm (non fourni)
- Poids maxi par porte : 30 kg
- Douche d'angle largeur receveur jusqu'à 1100 x 1100 mm
- **Les sens d'ouverture de la porte (droite ou gauche) doit être déterminé avant la réalisation des volumes**

Technical features

- For toughened glass doors 8 mm (not supplied)
- Maximum door weight : 30 kg
- Corner access maximum size of shower tray : 1100 mm x 1100 mm
- **The opening direction (right or left) must be determined before glass manufacture**

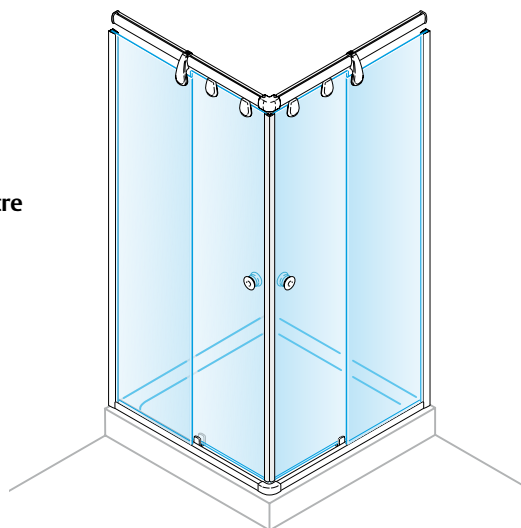

2820.**.2

Références / References



Kits complets / Complete kits



Chromé brillant
Bright chromium



Chromé mat
Matt chromium

Système d'angle 2 volumes fixes et 2 ouvrants couissants
Corner system 2 fixed panels and 2 sliding panels

2820.30.2

2820.31.2

LES + PRODUITS

The + product

Grande qualité
de finitions

Confort d'utilisation

High quality finishes

Great user comfort

TROUS FRAISES
Holes milled

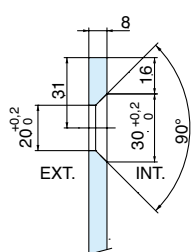

Largeur mur/mur Width wall/wall	Largeur de passage Passage width
1100	710
1000	640
900	570
800	500

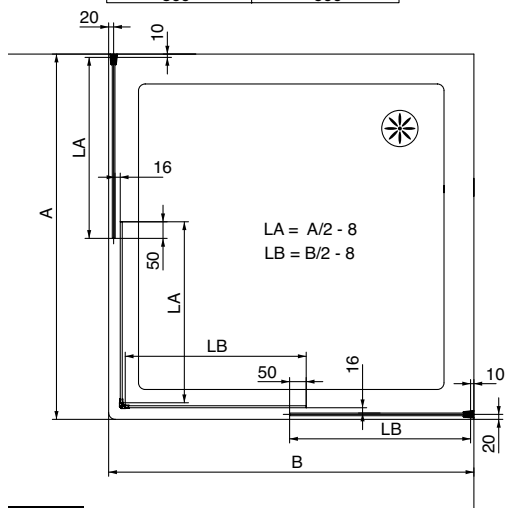

Attention : trous fraisés sur la face intérieure de la douche
Caution : holes milled on the inside face of the shower

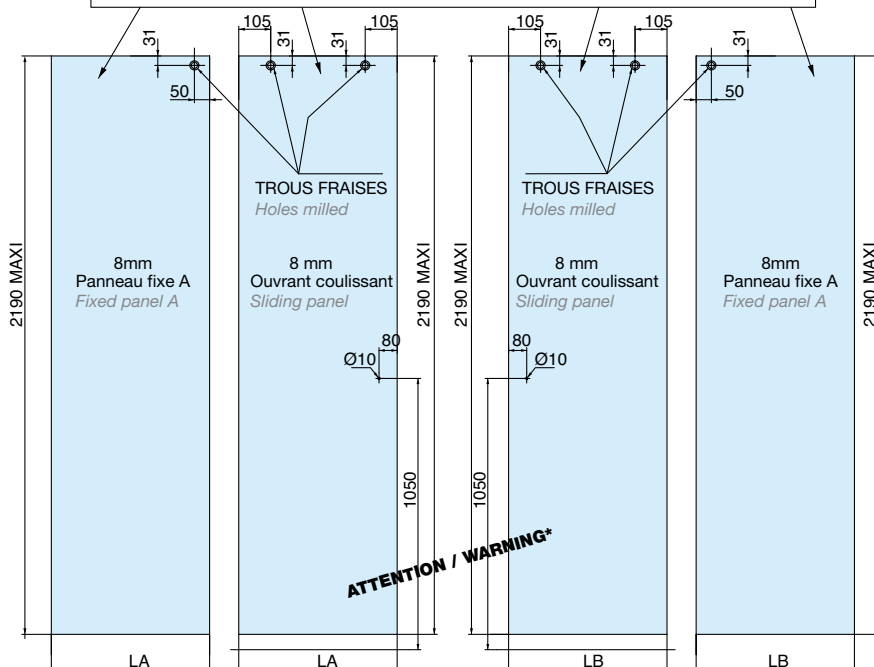

* Plan valable uniquement pour une porte à droite, pour porte à gauche, inverser le sens des fraisures

Drawing is valid only for doors on the right hand side, for the left hand side, reverse the direction of countersinking

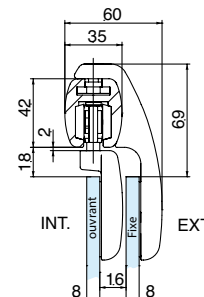
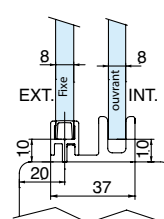
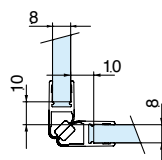
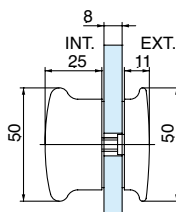

Caractéristiques techniques

- Pour verre trempé de 8 mm (non fourni)
- Poids maxi par porte : 30 kg
- Douche d'angle largeur receveur jusqu'à 1100 x 1100 mm
- Les sens d'ouverture de la porte (droite ou gauche) doit être déterminé avant la réalisation des volumes

Technical features

- For toughened glass doors 8 mm (not supplied)
- Maximum door weight : 30 kg
- Corner access maximum size of shower tray : 1100 mm x 1100 mm
- The opening direction (right or left) must be determined before glass manufacture

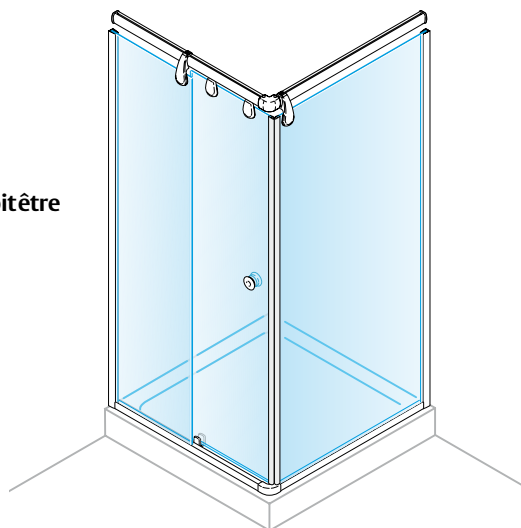

2820.**.3

Références / References



Kits complets / Complete kits



Chromé brillant
Bright chromium



Chromé mat
Matt chromium

Système d'angle 2 volumes fixes et 1 ouvrant coulissant
Corner system 2 fixed panels and 1 sliding panel

2820.30.3

2820.31.3

Largeur mur/mur Width wall/wall	Largeur de passage Passage width
1100	525
1000	475
900	425
800	375

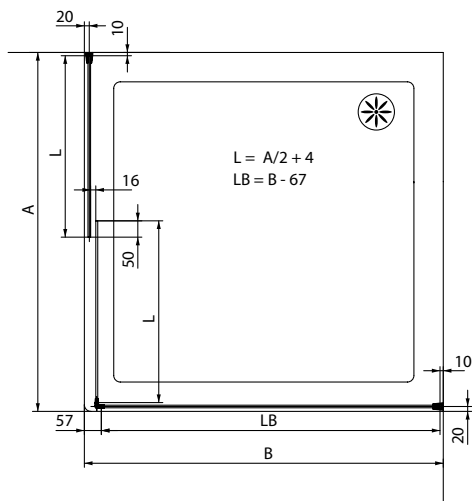

TROUS FRAISES
Holes milled

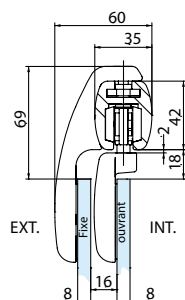
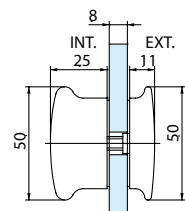
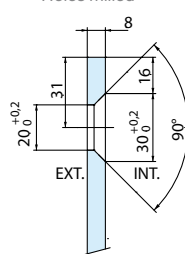

Attention : trous fraisés sur la face intérieure de la douche
Caution : holes milled on the inside face of the shower

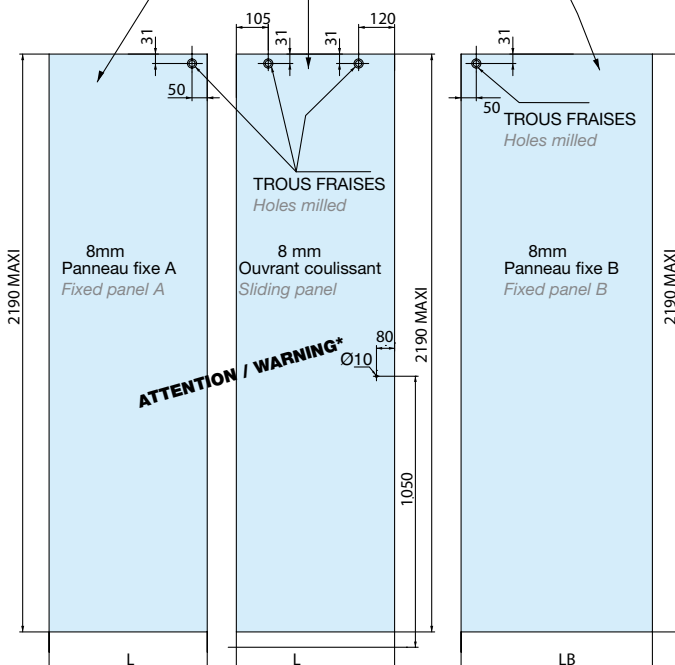

* Plan valable uniquement pour une porte à droite, pour porte à gauche, inverser le sens des fraises
Drawing is valid only for doors on the right hand side, for the left hand side, reverse the direction of countersinking

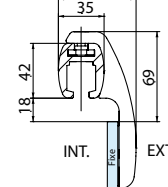
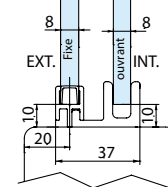
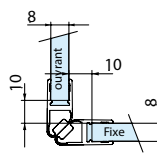

Eloa

Caractéristiques techniques

- Pour verre trempé de 8 mm (non fourni)
- Poids maxi par porte : 30 kg
- Douche d'angle largeur receveur jusqu'à 1100 x 1100 mm

• Les sens d'ouverture de la porte (droite ou gauche) doit être déterminé avant la réalisation des volumes

Technical features

- For toughened glass doors 8 mm (not supplied)
- Maximum door weight : 30 kg
- Corner access maximum size of shower tray : 1100 mm x 1100 mm

• The opening direction (right or left) must be determined before glass manufacture

2820.**.4

Références / References



Kits complets / Complete kits



Chromé brillant
Bright chromium



Chromé mat
Matt chromium

Système d'angle 2 volumes fixes et 1 ouvrant couissant
Corner system 2 fixed panels and 1 sliding panel

2820.30.4

2820.31.4

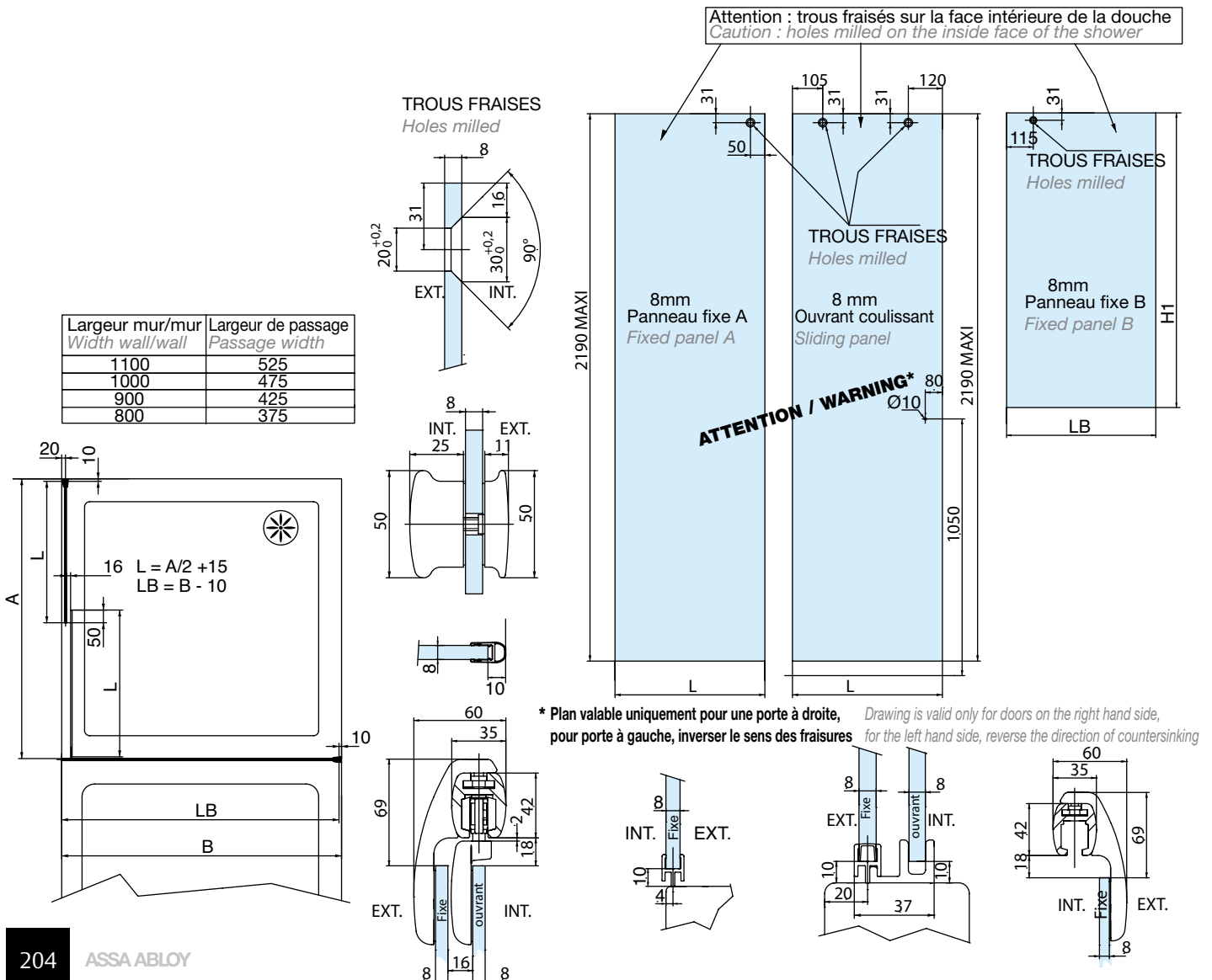

Caractéristiques techniques

- Pour verre trempé de 8 mm (non fourni)
- Poids maxi par porte : 30 kg
- Entre deux murs : largeur maxi 2200 mm
- **Les sens d'ouverture de la porte (droite ou gauche) doit être déterminé avant la réalisation des volumes**

Technical features

- For toughened glass doors 8 mm (not supplied)
- Maximum door weight : 30 kg
- Between two walls : maximum width 2200 mm
- **The opening direction (right or left) must be determined before glass manufacture**

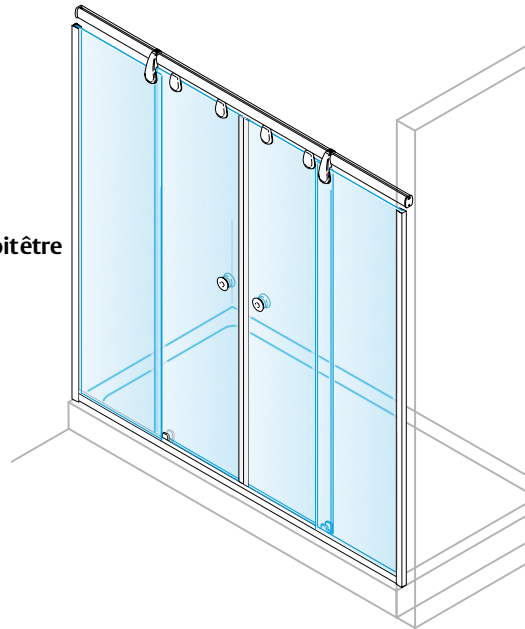

2820.**.5

Références / References



Kits complets / Complete kits



Chromé brillant
Bright chromium



Chromé mat
Matt chromium

Système mur/mur 2 volumes fixes et 2 ouvrants couissants
System wall/wall 2 fixed panels and 2 sliding panels

2820.30.5

2820.31.5

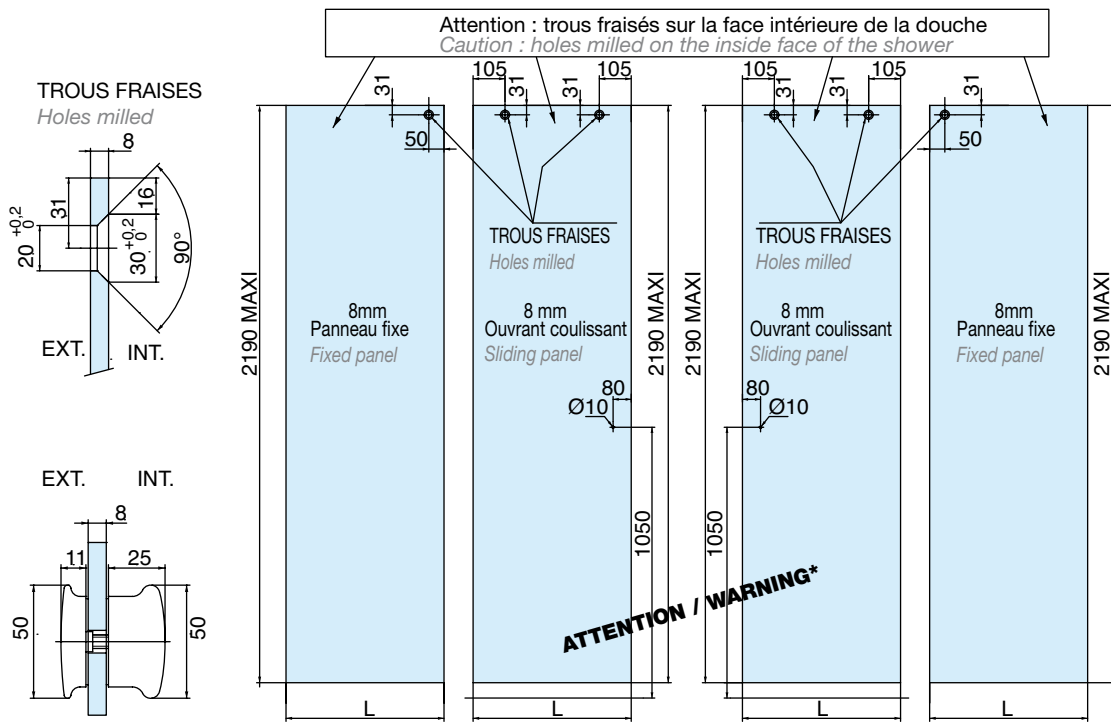

* Plan valable uniquement pour une porte à droite, pour porte à gauche, inverser le sens des fraises

Plan is valid only for doors on the right hand side, for the left hand side, reverse the direction of countersinking

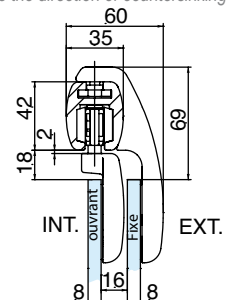
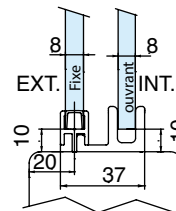
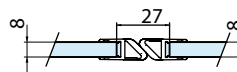
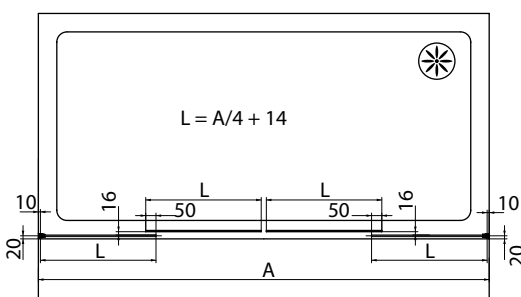

Systèmes
couissants
pour douches
*Sliding shower
system*

Eloa

Caractéristiques techniques

- Pour verre trempé de 8 mm (non fourni)
- Poids maxi par porte : 30 kg
- Entre deux murs : largeur maxi 1300 mm
- **Les sens d'ouverture de la porte (droite ou gauche) doit être déterminé avant la réalisation des volumes**

Technical features

- For toughened glass doors 8 mm (not supplied)
- Maximum door weight : 30 kg
- Between two walls : maximum width 1300 mm
- **The opening direction (right or left) must be determined before glass manufacture**

2820.**.6

Références / References



Kits complets / Complete kits

Système mur/mur 2 volumes repliables
System wall/wall 2 folding panels



Chromé brillant
Bright chromium



Chromé mat
Matt chromium

2820.30.6

2820.31.6

LES + PRODUITS

The + product

Accès adapté
pour personne
à mobilité réduite

*Adapted
for disabled people*

TROUS FRAISES *Holes milled*

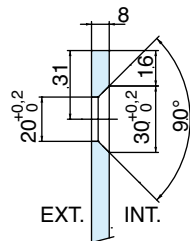

ENCOCHE MV *Notch MV*

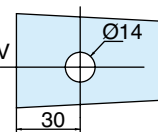

ENCOCHE VV *Notch VV*

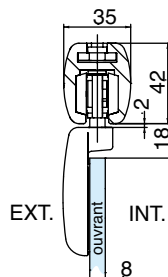
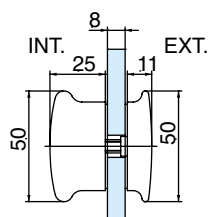
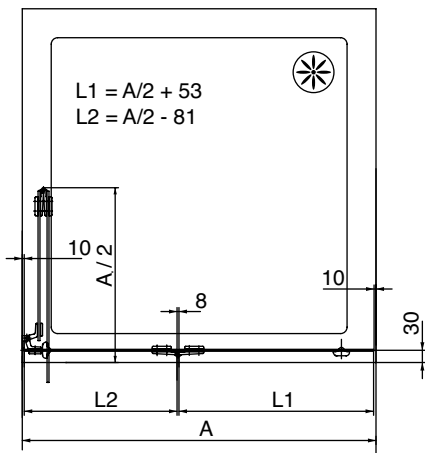
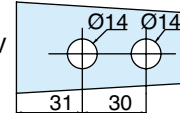

Attention : trous fraisés sur la face intérieure de la douche
Caution : holes milled on the inside face of the shower

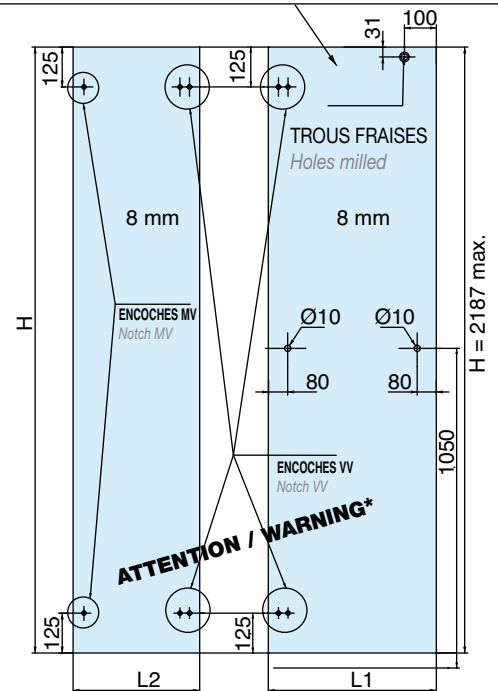

* Plan valable uniquement pour une porte repliable à gauche,
pour porte repliable à droite, inverser le sens de la fraisure
Drawing only valid for a folding door on the left,

Fold Door folding on the right, reverse the direction of countersinking

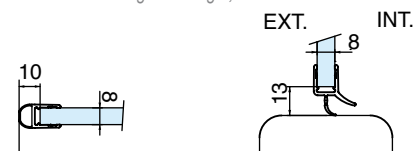

Caractéristiques techniques

- Pour verre trempé de 8 mm (non fourni)
- Poids maxi par porte : 30 kg
- Douche d'angle largeur receveur jusqu'à 1100 x 1100 mm

• Les sens d'ouverture de la porte (droite ou gauche) doit être déterminé avant la réalisation des volumes

Technical features

- For toughened glass doors 8 mm (not supplied)
- Maximum door weight : 30 kg
- Corner access maximum size of shower tray : 1100 mm x 1100 mm

• The opening direction (right or left) must be determined before glass manufacture

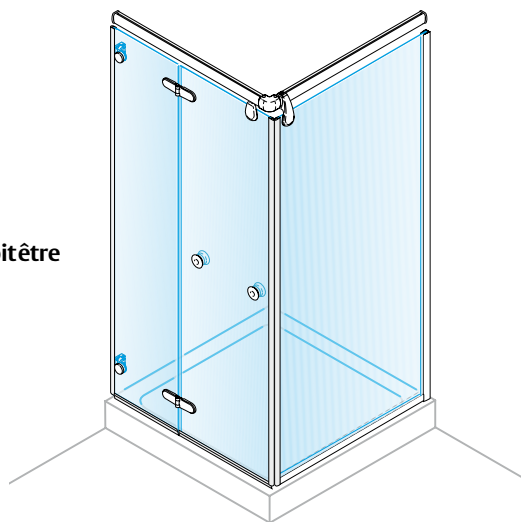

2820.**.7

Références / References



Kits complets / Complete kits



Chromé brillant
Bright chromium



Chromé mat
Matt chromium

Système d'angle 1 volume fixe et 2 volumes repliables
Corner system 1 fixed panel and 2 folding panels

2820.30.7

2820.31.7

TROUS FRAISES
Holes milled

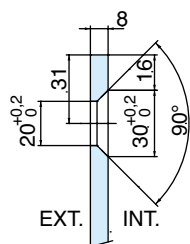

ENCOCHE MV
Notch MV

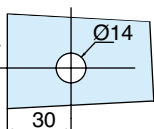

ENCOCHE VV
Notch VV

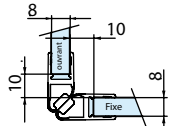
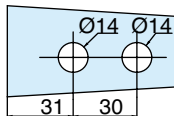

Attention : trous fraisés sur la face intérieure de la douche
Caution : holes milled on the inside face of the shower

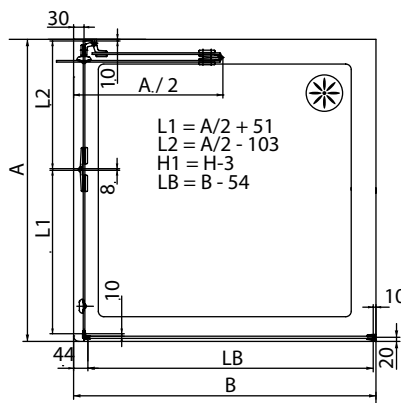
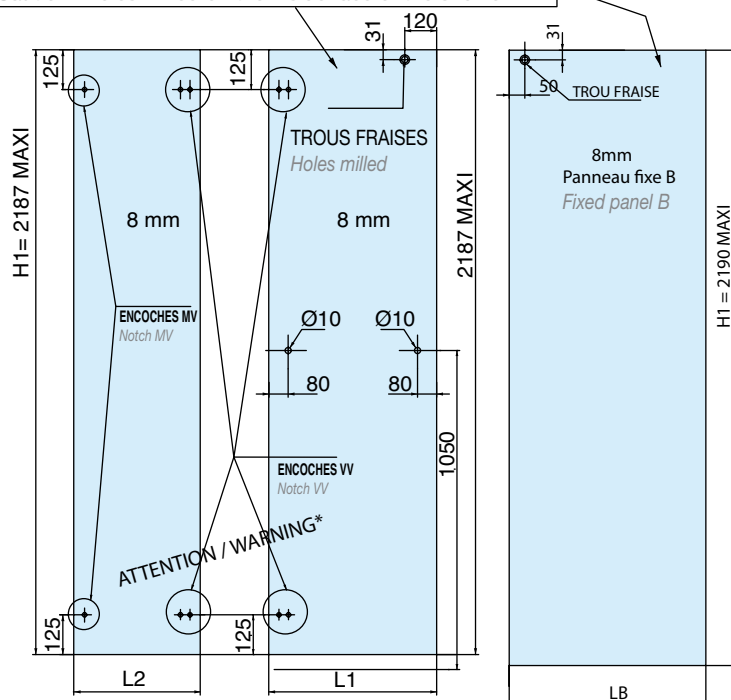

* Plan valable uniquement pour une porte repliable à gauche, pour porte repliable à droite, inverser le sens de la fraisure
Drawing only valid for a folding door on the left, Fold Door folding on the right, reverse the direction of countersinking

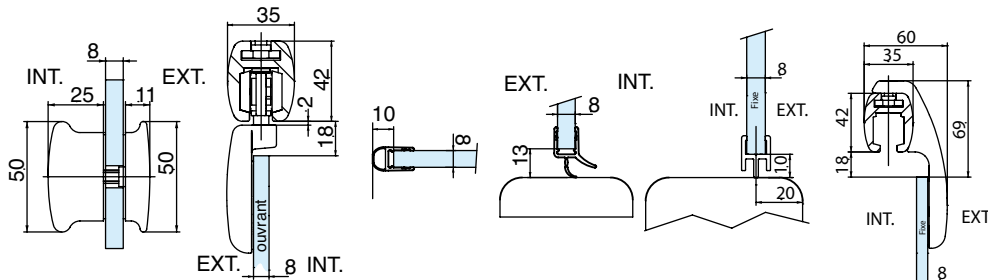

Systèmes
couissants
pour douches
Sliding shower
system

Eloa

Caractéristiques techniques

- Pour verre trempé de 8 mm (non fourni)
- Poids maxi par porte : 30 kg
- Douche d'angle largeur receveur jusqu'à 1100 x 1100 mm

• Les sens d'ouverture de la porte (droite ou gauche) doit être déterminé avant la réalisation des volumes

Technical features

- For toughened glass doors 8 mm (not supplied)
- Maximum door weight : 30 kg
- Corner access maximum size of shower tray : 1100 mm x 1100 mm

• The opening direction (right or left) must be determined before glass manufacture

2820.**.9

Références / References



Kits complets / Complete kits



Chromé brillant
Bright chromium



Chromé mat
Matt chromium



Laqué Blanc 9010
Lacquered white RAL 9010

Système d'angle 1 volume fixe, 1 ouvrant coulissant et 2 volumes repliables
Corner system 1 fixed panel, 1 sliding panel and 2 folding panels

2820.30.9

2820.31.9

2820.51.9

LES + PRODUITS

The + product

Accès adapté
pour personne
à mobilité réduite

Adapted
for disabled people

TROUS FRAISES Holes milled

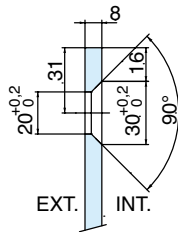

ENCOCHE MV
Notch MV

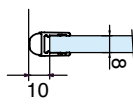
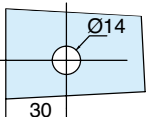

ENCOCHE VV
Notch VV

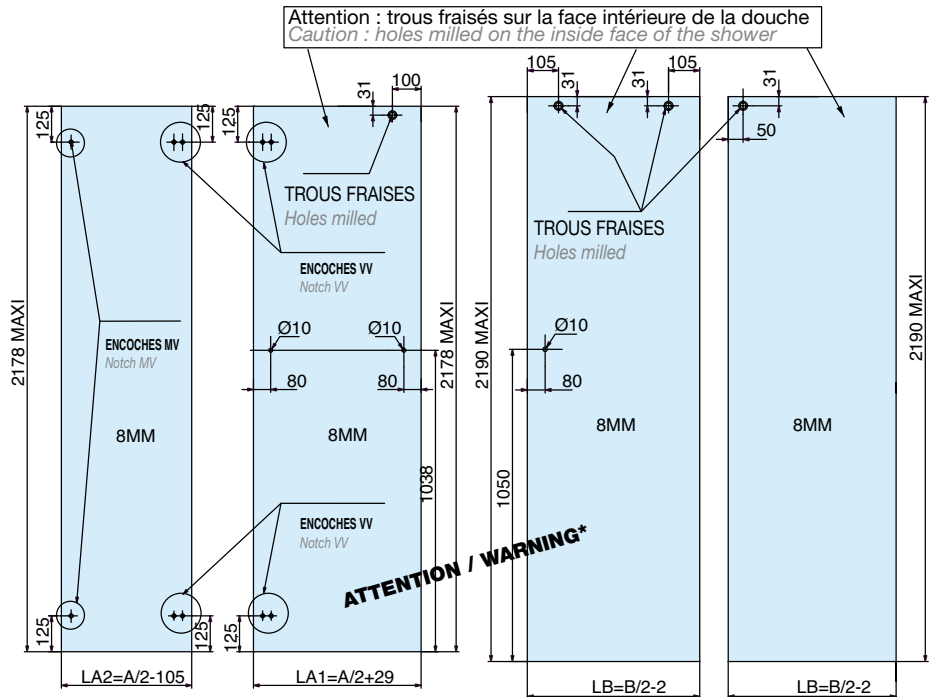
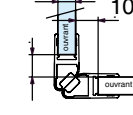
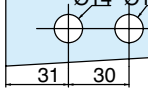

* Plan valable uniquement pour cette configuration, pour l'autre, inverser le sens de la fraisure

Drawing only valid for this configuration, for the other, reverse the direction of countersinking

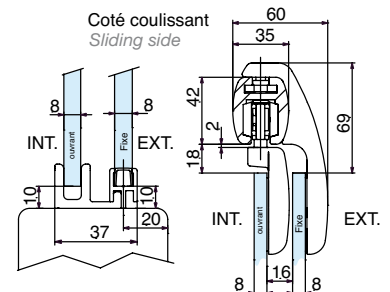
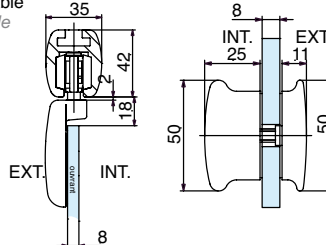
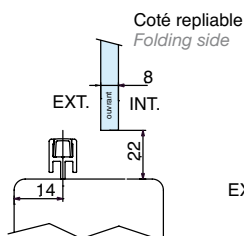
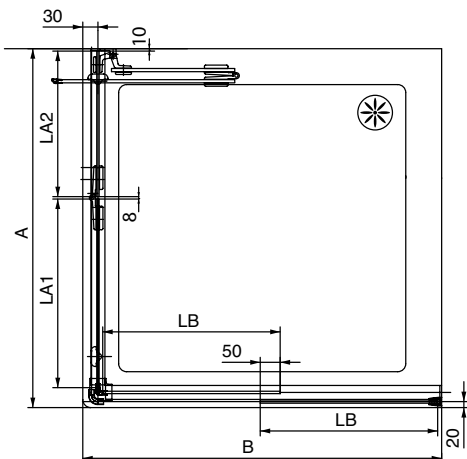

Systèmes
couissants
pour douches
*Sliding shower
system*



Profil pour
pare baignoires
*Hinged profile
for bath screens*

Filéo

Caractéristiques techniques

- Système de came levante intégrée pour un dégagement aisé du joint de seuil
- Profil recoupable longueur 1520 mm embouts compris
- Pour verre trempé de 6 mm (non fourni)
- Montage sur 3 encoches
- Largeur de porte maxi 1000 mm
- Poids maxi par porte 25 kg
- Livré avec joint bas de porte 1809.66.0
- Réglage de l'angle de la porte par tranche de 22,5°

Technical features

- Rising system for a better bottom sealing strip release
- Profile can be cut down to length 1520 mm with top and bottom end caps
- For 6 mm thick toughened glass (not supplied)
- Assembled onto 3 notches
- Door width maximum 1000 mm
- Maximum weight per door 25 kg
- Supplied with sealing strip for bottom of door 1809.66.0
- Angle of door adjustable by sections of 22,5°

LES + PRODUITS

The + product

Esthétique

Grande qualité
de finitions

Étanchéité optimisée

Joint passant

Système
de came levante
intégrée pour
un dégagement aisé
du joint de seuil

Attractive

High quality finishes

Optimized sealing

Full sealing strip

Rising system for
a better bottom
sealing strip release

2720.**.2L15

Références / References



Profil articulé pour pare baignoire lg 1520 mm
Hinged profile for bath screens 1520 mm length



Alu poli brillant
Polished aluminium



Laqué Blanc 9010
Lacquered white RAL 9010

2720.13.2L15

2720.51.2L15

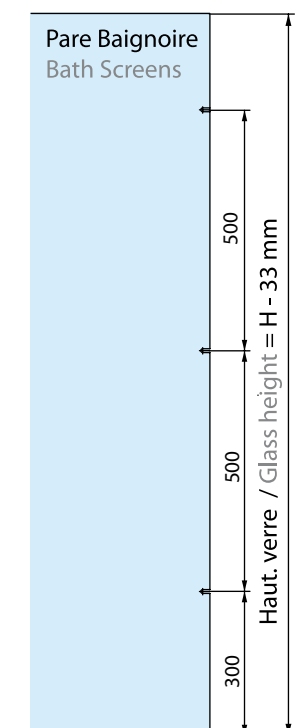
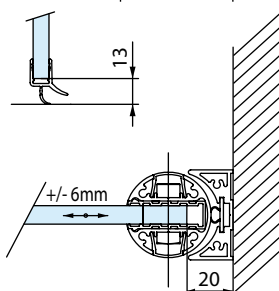
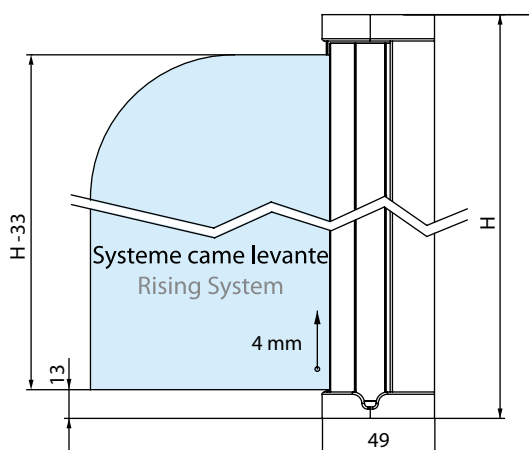
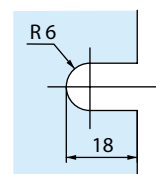
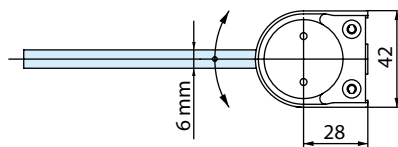

Profil pour
pare baignoires
*Hinged profile
for bath screens*

**B
A
I
N**



Profil pour
pare douches
*Hinged profile
for shower doors*

Filéo

Caractéristiques techniques

- Système de câme levante intégrée pour un dégagement aisé du joint de seuil
- Profil recoupable longueur 2220 mm embouts compris
- Pour verre trempé de 6 ou 8 mm (non fourni)
- Montage sur 4 encoches
- Largeur de porte maxi 800 mm
- Poids maxi par porte 30 kg
- Livré avec joint bas de porte 1809.66.0
- Réglage de l'angle de la porte par tranche de 22,5°

Technical features

- Rising system for a better bottom sealing strip release
- Profile can be cut down to length 2220 mm with top and bottom end caps
- For 6 or 8 mm thick toughened glass (not supplied)
- Assembled onto 4 notches
- Door width maximum 800 mm
- Maximum weight per door 30 kg
- Supplied with sealing strip for bottom of door 1809.66.0
- Angle of door adjustable by sections of 22,5°

2720.**.2L22

Références / References



Profil articulé pour pare douche lg 2220 mm
Hinged profile for shower doors 2220 mm length

2720.13.2L22 2720.51.2L22

LES + PRODUITS
The + product

Esthétique

Grande qualité
de finitions

Étanchéité optimisée

Joint passant

Système
de câme levante
intégrée pour
un dégagement aisé
du joint de seuil

Attractive

High quality finishes

Optimized sealing

Full sealing strip

Rising system for
a better bottom
sealing strip release

2720.**.3L22

Références / References



Profil articulé pour pare douche lg 2220 mm
Hinged profile for shower doors 2220 mm length

2720.13.3L22 2720.51.3L22

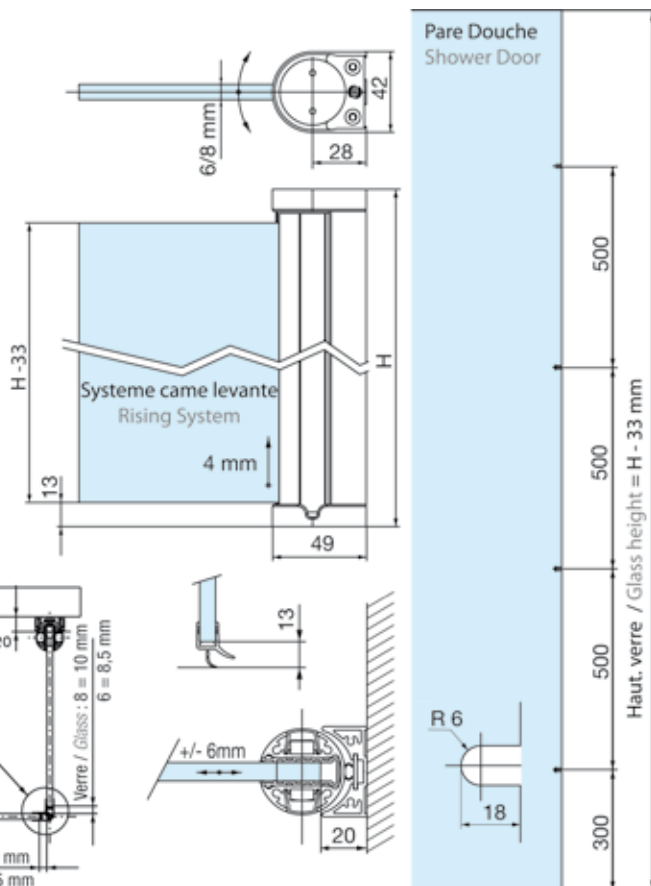
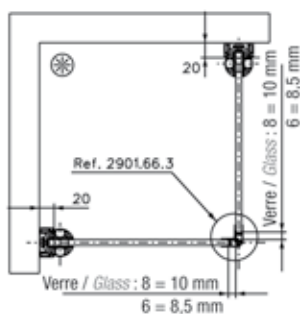
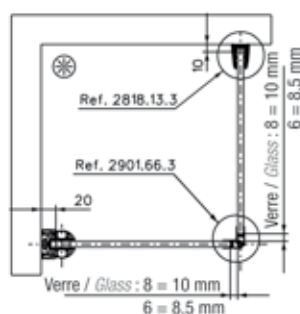
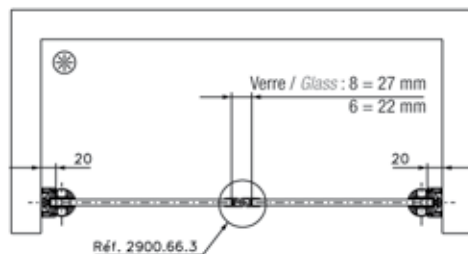
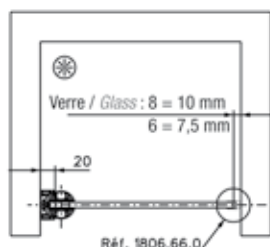

Profil pour
pare douches
*Hinged profile
for shower doors*



Charnières pour
pare douches
*Hinges for
shower screens*

Kubika

Caractéristiques techniques

- Poids maxi par porte 45 kg
- Pour verre trempé de 8 et 10 mm (non fourni)
- Montage sur 2 trous Ø 16 mm
- Ouverture à 90°
- Livrée avec vis de fixation et intercalaires
- Unité de vente : Charnière simple, conditionnée par 2
- Charnière double, conditionnée par 1

Technical features

- Maximum weight per door 45 kg
- For 8 to 10 mm thick toughened glass (not supplied)
- Assembled onto holes Ø 16mm
- Opening through 90°
- Supplied with screws and spacers.
- Sales unit : Single hinge packaging : 2
- Glass to glass hinge packaging : 1



SYSTÈMES BREVETÉS PATENTED SYSTEM

- Système de réglage d'angle précis
- Système anti-bruit
- Adjustment System of the door angle
- Anti-noise system

LES + PRODUITS

The + product

Joint passant

Design

Réglage précis de
l'angle de la porte

Grande qualité
de finitions

Système anti-bruit

Full sealing strip

Design

Precise adjustment
of the door angle

High quality finishes

Anti-noise system

3460.**.0R

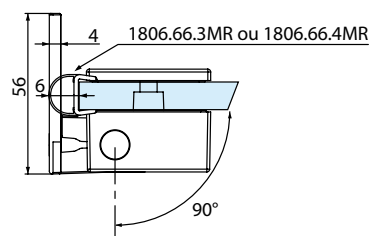
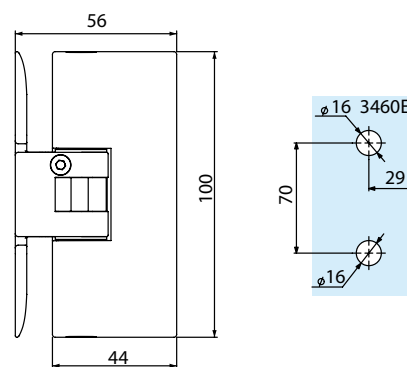

Références / References



Chromé brillant
Bright chromium



Chromé mat
Matt chromium



Effet Inox
Stainless steel effect

Charnière simple réglable blocage à 90°, axe déporté ouverture d'un seul côté
Adjustable single shower hinge 90° blocking point, offset axes opening on one side only

3460.30.0R

3460.31.0R

3460.35.0R

- S'utilise avec joint bourrelet masse réduite
1806.66.3MR ou 1806.66.4MR

- Used with super slim seal with lip compressor
1806.66.3MR or 1806.66.4MR



3462.**.0R

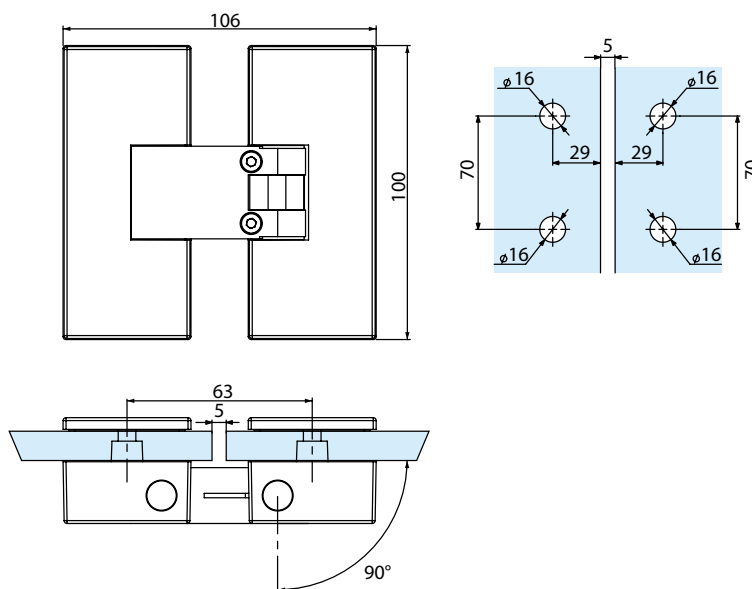

Références / References

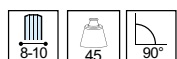

Chromé brillant
Bright chromium



Chromé mat
Matt chromium



Effet Inox
Stainless steel effect

Charnière double réglable blocage à 90°, axe déporté ouverture d'un seul côté
*Adjustable double shower hinge 90° blocking point, offset axes opening
on one side only*

3462.30.0R

3462.31.0R

3462.35.0R

• S'utilise avec joint bourrelet masse réduite
1806.66.3MR ou 1806.66.4MR

• Used with super slim seal with lip compressor
1806.66.3MR or 1806.66.4MR

Charnières pour
pare douches
*Hinges for
shower screens*

Mélora

Caractéristiques techniques

- Poids maxi par porte 60 kg
- Pour verre trempé de 8, 10 et 12 mm
- Montage sur encoche 3560BE
- Ouverture à 180°
- Livrée avec vis de fixation
- Unité de vente : Charnière simple, conditionnée par 2
Charnière double, conditionnée par 1

Technical features

- Maximum weight per door 60 kg
- For 8, 10 or 12 mm thick toughened glass
- For notch 3560BE.
- Opening through 180°
- Supplied with screws.
- Sales unit : Single hinge packaging : 2
Glass to glass hinge packaging : 1



SYSTÈMES BREVETÉS PATENTED SYSTEM

- Système de réglage d'angle précis
- Système anti-bruit
- Adjustment System of the door angle
- Anti-noise system

LES + PRODUITS

The + product

Réglage précis de
l'angle de la porte

Grande qualité
de finitions

Certifié TUV

Système anti-bruit

*Precise adjustment
of the door angle*

High quality finishes

TUV certified

Anti-noise system

3560.**.0R

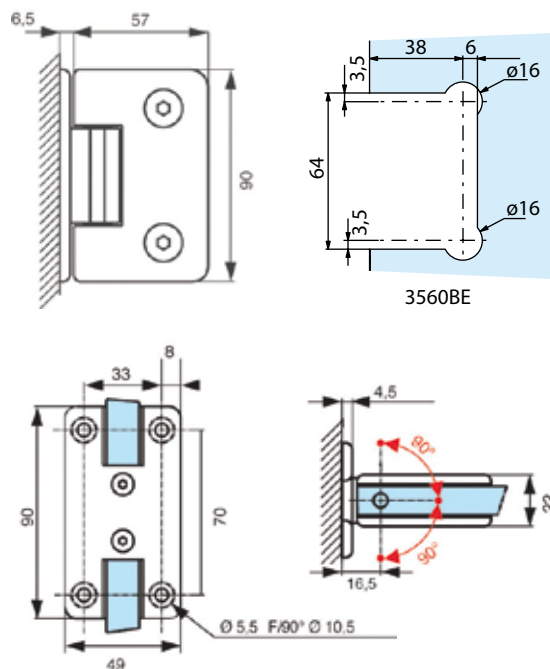

Références / References

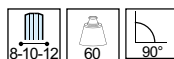

Laiton poli PVD
Polished brass PVD



Chromé brillant
Bright chromium



Chromé mat
Matt chromium



Effet Inox
Stainless steel effect

Charnière simple réglable
blocage à 90°, 4 trous de fixation
*Single adjustable hinge 90° blocking
with 4 fixing points*

3560.05.0R

3560.30.0R

3560.31.0R

3560.35.0R

3561.**.0R

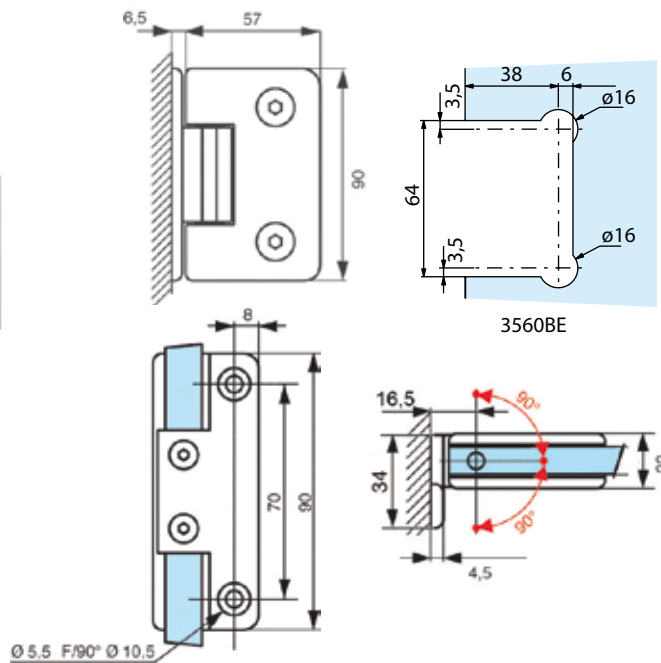

Charnières pour
pare douches
*Hinges for
shower screens*

Références / References

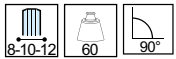

Laiton poli PVD
Polished brass PVD



Chromé brillant
Bright chromium



Chromé mat
Matt chromium



Effet Inox
Stainless steel effect

Charnière simple réglable
blocage à 90°, 2 trous de fixation
*Single adjustable hinge 90° blocking
with 2 fixing points*

3561.05.0R

3561.30.0R

3561.31.0R

3561.35.0R

3562.**.0R

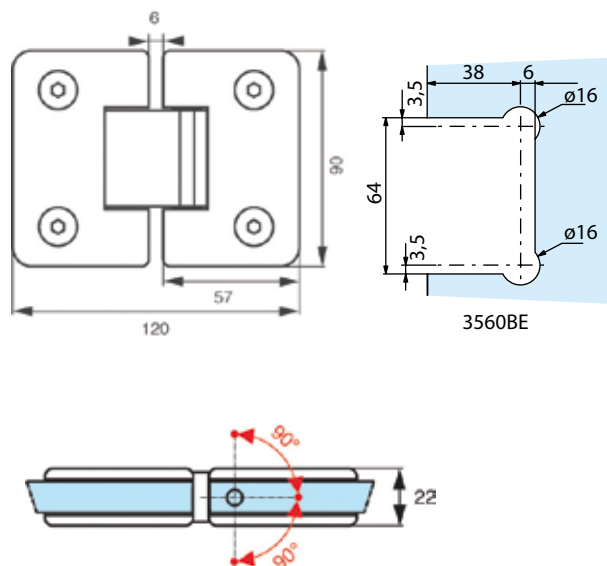

Références / References

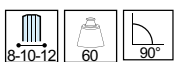

Laiton poli PVD
Polished brass PVD



Chromé brillant
Bright chromium



Chromé mat
Matt chromium



Effet Inox
Stainless steel effect

Charnière double verre/verre
réglable blocage à 90°
*Glass to glass adjustable shower
hinge 90° blocking point*

3562.05.0R

3562.30.0R

3562.31.0R

3562.35.0R

Charnières pour
pare douches
*Hinges for
shower screens*

Mélora

3562.**.2R

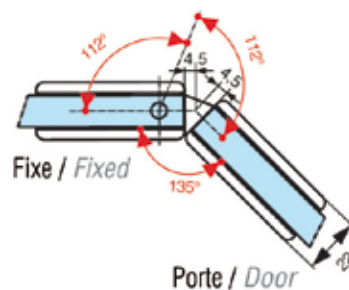
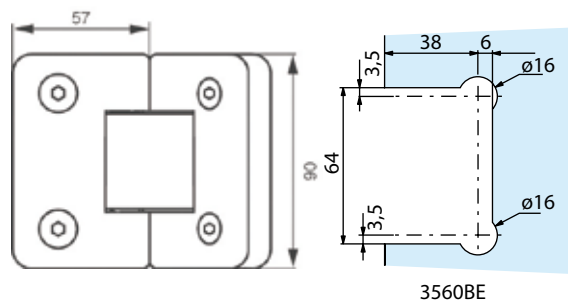

Références / References

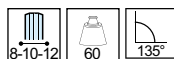

Charnière double verre/verre
réglable blocage à 135°
*Glass to glass adjustable shower
hinge 135°blocking point*



Laiton poli PVD
Polished brass PVD

3562.05.2R



Chromé brillant
Bright chromium

3562.30.2R



Chromé mat
Matt chromium

3562.31.2R



Effet Inox
Stainless steel effect

3562.35.2R

Charnières pour
pare douches
*Hinges for
shower screens*



Charnières pour
pare douches
*Hinges for
shower screens*

Mélora SQ

Caractéristiques techniques

- Poids maxi par porte 60 kg
- Pour verre trempé de 8, 10, 12 mm
- Montage sur encoche 3560BE
- Ouverture à 180°
- Livrée avec vis de fixation
- Unité de vente : Charnière simple, conditionnée par 2
Charnière double, conditionnée par 1

Technical features

- Maximum weight per door 60 kg
- For 8, 10 and 12 mm thick toughened glass
- For notch 3560BE.
- Opening through 180°
- Supplied with screws
- Sales unit : Single hinge packaging : 2
Glass to glass hinge packaging : 1



LES + PRODUITS

The + product

Design

Réglage précis de
l'angle de la porte

Grande qualité
de finitions

Certifié TUV

Système anti-bruit

Design

Precise adjustment
of the door angle

High quality finishes

TUV certified

Anti-noise system



SYSTÈMES BREVETÉS
PATENTED SYSTEM

- Système de réglage d'angle précis
- Système anti-bruit
- Adjustment System of the door angle
- Anti-noise system

3560.**.ORSQ

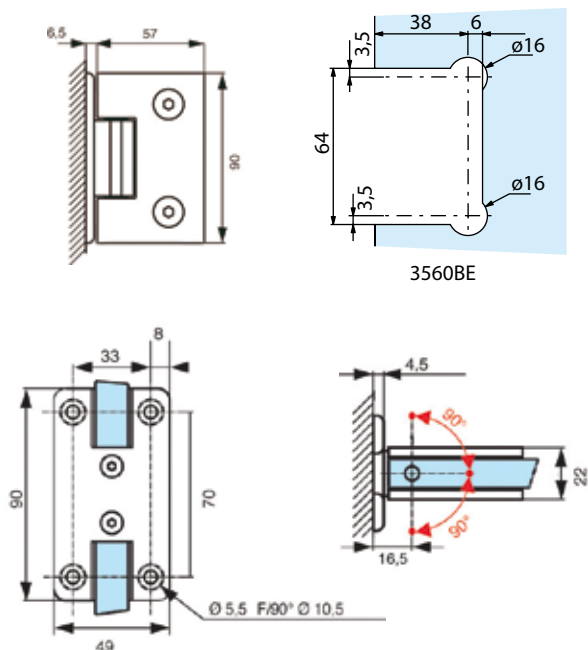

Références / References

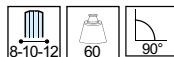

Chromé brillant
Bright chromium



Chromé mat
Matt chromium



Effet Inox
Stainless steel effect

Charnière simple réglable blocage à 90°, 4 trous de fixation
Single adjustable hinge 90° blocking with 4 fixing points

3560.30.ORSQ

3560.31.ORSQ

3560.35.ORSQ

3561.**.0RSQ

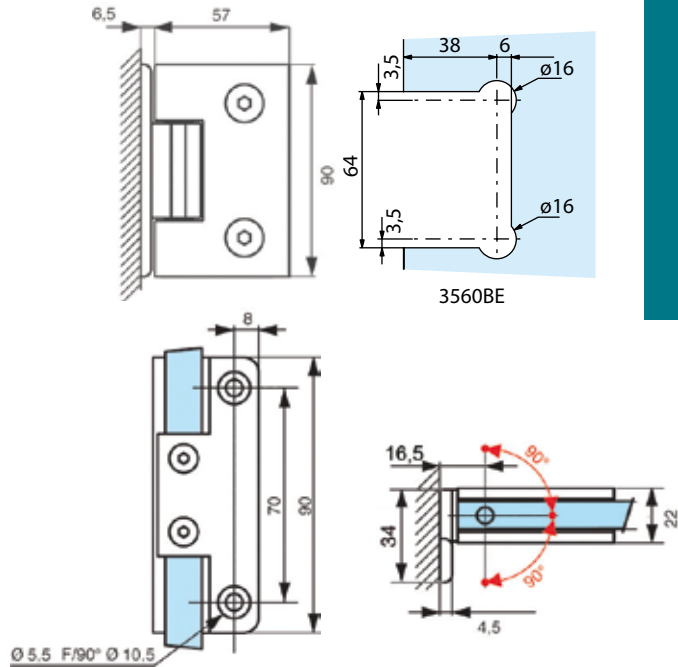

Charnières pour
pare douches
*Hinges for
shower screens*

Références / References



Charnière simple réglable blocage à 90°, 2 trous de fixation
Single adjustable hinge 90° blocking with 2 fixing points

3561.30.0RSQ

3561.31.0RSQ

3561.35.0RSQ

3562.**.0RSQ

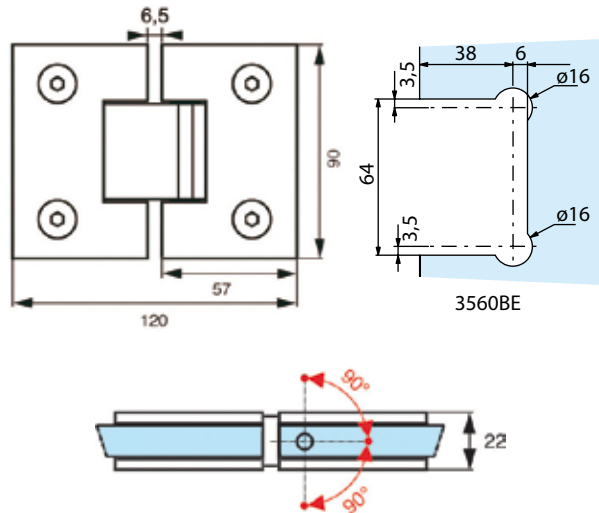

Références / References



Charnière double verre/verre réglable blocage à 90°
Glass to glass adjustable shower hinge 90° blocking point

3562.30.0RSQ

3562.31.0RSQ

3562.35.0RSQ

Charnières pour
pare douches
*Hinges for
shower screens*

Marine

Caractéristiques techniques

- Platine avec trous oblongs pour un réglage en profondeur
- Vis et platine intégralement cachées pour une esthétique améliorée
- Systèmes brevetés
- Réglage précis de l'angle de la porte breveté
- Système anti-bruit breveté
- Pour porte jusqu'à 60kg
- Ouverture à 180°
- Point de rotation centré, va et vient possible
- Grande qualité de finitions
- Testé suivant la norme EN 1670 grade 5
- Garantie 5 ans
- Pour verre trempé de 8 et 10 mm
- Montage sur encoche 3260BE
- Livrée avec vis de fixation
- Unité de vente : Charnière simple, conditionnée par 2
Charnière double, conditionnée par 1



LES + PRODUITS

The + product

Vis et platine
intégralement
cachées pour
une esthétique
améliorée

Réglage précis de
l'angle de la porte

Grande qualité
de finitions

Certifié TUV

Système anti-bruit

*Screw and plate
cover for improved
aesthetic*

*Precise adjustment
of the door angle*

High quality finishes

TUV certified

Anti-noise system

3260.**.0RCV

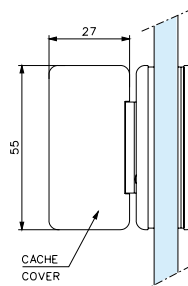
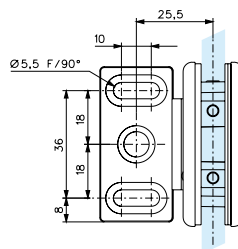

SYSTÈMES BREVETÉS PATENTED SYSTEM

- Système de réglage d'angle précis
- Système anti-bruit
- *Adjustment System of the door angle*
- *Anti-noise system*

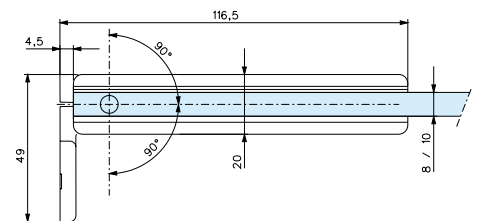
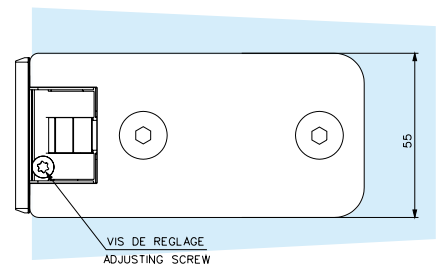
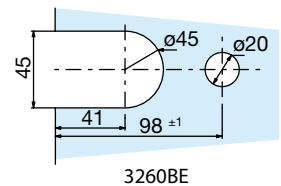

Références / References

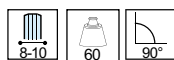

Laiton poli PVD
Polished brass PVD

Chromé brillant
Bright chromium

Chromé mat
Matt chromium

Effet Inox
Stainless steel effect

Laqué blanc 9010
Lacquered white RAL 9010

Charnière simple réglable
blocage à 90°, 3 trous de fixation
*Single adjustable hinge 90°
blocking with 3 fixing points*

3260.05.0RCV

3260.30.0RCV

3260.31.0RCV

3260.35.0RCV

3260.51.0RCV

3261.**.0R

Charnières pour
pare douches
*Hinges for
shower screens*

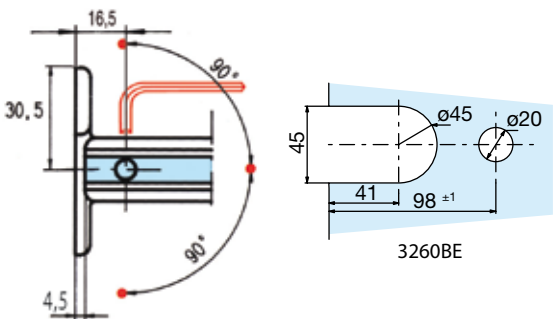
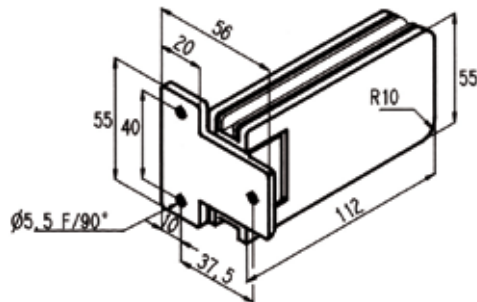

Références / References



- Laiton poli PVD
Polished brass PVD
- Chromé brillant
Bright chromium
- Chromé mat
Matt chromium
- Effet Inox
Stainless steel effect
- Laqué blanc 9010
Lacquered white RAL 9010

Charnière simple réglable
blocage à 90°, 3 trous de fixation
*Single adjustable hinge 90°
blocking with 3 fixing points*

- 3261.05.0R
- 3261.30.0R
- 3261.31.0R
- 3261.35.0R
- 3261.51.0R

3262.**.0R

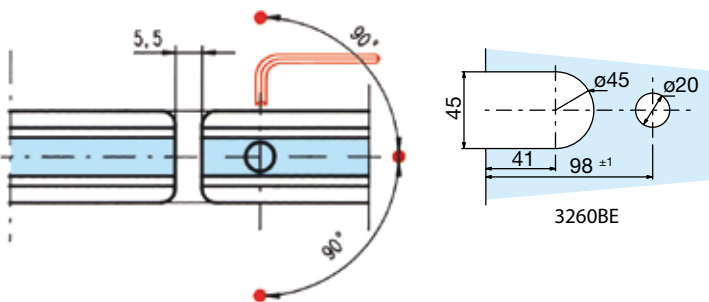
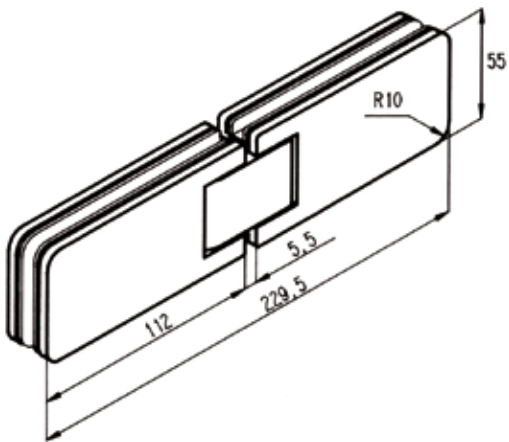

Références / References



- Laiton poli PVD
Polished brass PVD
- Chromé brillant
Bright chromium
- Chromé mat
Matt chromium
- Effet Inox
Stainless steel effect
- Laqué blanc 9010
Lacquered white RAL 9010

Charnière double verre/verre réglable
blocage à 90°
*Glass to glass adjustable shower
hinge 90° blocking point*

- 3262.05.0R
- 3262.30.0R
- 3262.31.0R
- 3262.35.0R
- 3262.51.0R

Charnières pour
pare douches
*Hinges for
shower screens*

3262.**.2R

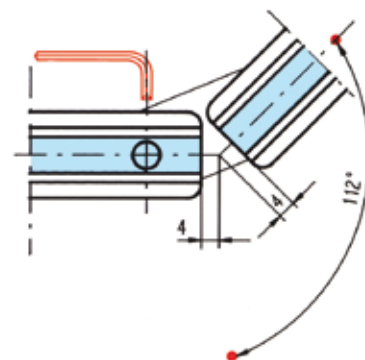
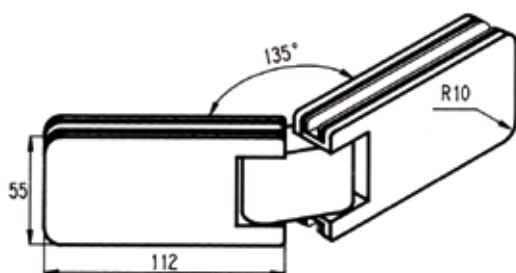
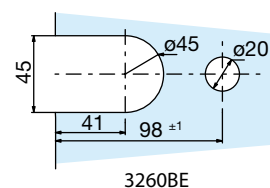

Références / References



Laiton poli PVD
Polished brass PVD



Chromé brillant
Bright chromium



Chromé mat
Matt chromium



Effet Inox
Stainless steel effect



Laqué blanc 9010
Lacquered white RAL 9010

Charnière double verre/verre réglable
blocage à 135°
*Glass to glass adjustable shower hinge
135° blocking point*

3262.05.2R

3262.30.2R

3262.31.2R

3262.35.2R

3262.51.2R

3264.**.0R

Charnières pour pare douches Hinges for shower screens

Caractéristiques techniques

- Montage sur encoche 3264BE pour le volume mobile et 3260BE pour le volume fixe
- Pour verre de 8 mm B = 8 mm C = 7 mm
- Pour verre de 10 mm B = 7 mm C = 6 mm

Technical features

- For mobile panel on notch 3264BE and 3260BE for fixed panel
- For 8 mm glass B = 8 mm C = 7 mm
- For 10 mm glass B = 7 mm C = 6 mm

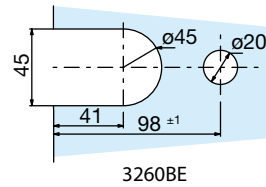
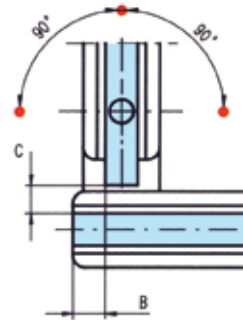
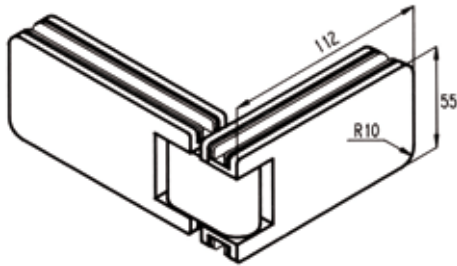
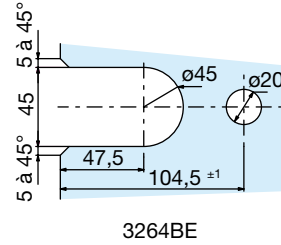

Références / References



Laiton poli PVD
Polished brass PVD



Chromé brillant
Bright chromium



Chromé mat
Matt chromium



Effet Inox
Stainless steel effect



Laqué blanc 9010
Lacquered white RAL 9010

Charnière double d'angle, réglable
Corner adjustable shower hinge

3264.05.0R

3264.30.0R

3264.31.0R

3264.35.0R

3264.51.0R

Charnières
réglables pour
pare douche
*Adjustable hinges
for shower screens*

Marine SQ

Caractéristiques techniques

- Poids maxi par porte 60 kg
- Pour verre trempé de 8 et 10 mm
- Montage sur encoche 3660BE
- Ouverture à 180°
- Livrée avec vis de fixation
- Unité de vente : Charnière simple, conditionnée par 2
Charnière double, conditionnée par 1

Technical features

- Maximum weight per door 60 kg
- For 8 to 10 mm thick toughened glass
- For notch 3660BE
- Opening through 180°
- Supplied with screws and spacers
- Sales unit : Single hinge packaging : 2
Glass to glass hinge packaging : 1



LES + PRODUITS

The + product

Design

Réglage précis
de l'angle
de la porte

Grande qualité
de finitions

Certifié TUV

Système anti-bruit

Design

*Precise adjustment
of the door angle*

High quality finishes

TUV certified

Anti-noise system



**SYSTÈMES BREVETÉS
PATENTED SYSTEM**

- Système de réglage d'angle précis
- Système anti-bruit
- *Adjustment System of the door angle*
- *Anti-noise system*

3660..ORSQ**

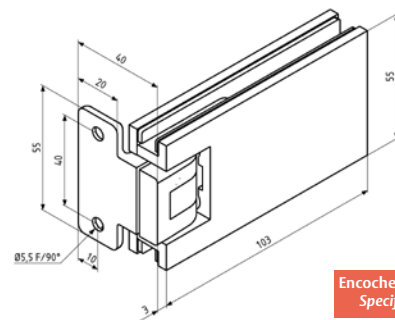

Encoche spécifique
Specific notch

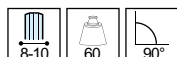
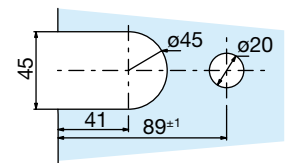

Chromé brillant
Bright chromium



Chromé mat
Matt chromium

Charnière simple réglable blocage à 90°, 2 trous de fixation
Single adjustable hinge 90° blocking with 2 fixing points

3660.30.ORSQ

3660.31.ORSQ

3662.**.ORSQ

Charnières réglables pour pare douche
Adjustable hinges for shower screens

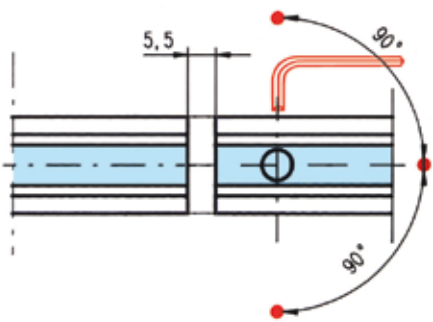
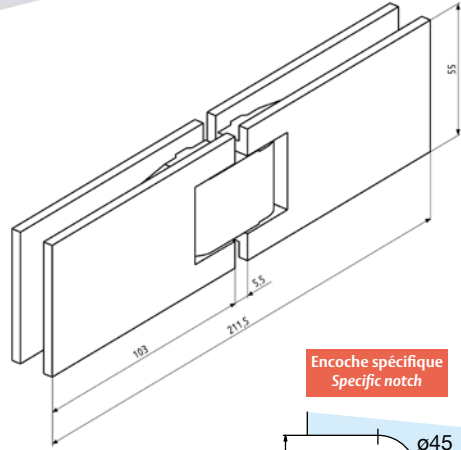

Encoche spécifique
Specific notch

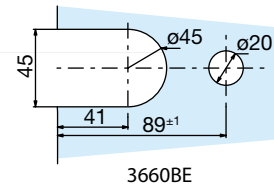

Chromé brillant
Bright chromium



Chromé mat
Matt chromium

Charnière double verre/verre réglable blocage à 90°
Glass to glass adjustable shower hinge 90° blocking point

3662.30.ORSQ 3662.31.ORSQ

Charnières
réglables pour
pare douche
*Adjustable hinges
for shower screens*

Carréa

Caractéristiques techniques

- Platine avec trous oblongs pour un réglage en profondeur
- Vis et platine intégralement cachées pour une esthétique améliorée
- Systèmes brevetés
- Réglage précis de l'angle de la porte breveté
- Système anti-bruit breveté
- Pour porte jusqu'à 45kg
- Ouverture à 180°
- Point de rotation centré, va et vient possible
- Grande qualité de finitions
- Testé suivant la norme EN 1670 grade 5
- Garantie 5 ans
- Pour verre trempé de 8 et 10 mm
- Montage sur encoche 3760BE
- Livrée avec vis de fixation
- Unité de vente : Charnière simple, conditionnée par 2
Charnière double, conditionnée par 1

Technical features

- Plate with slotted holes allowing depth adjustment
- Screw and plate cover for improved aesthetic
- Patented system
- Patented precise adjustment of the door angle
- Patented anti-noise system
- For doors up to 45kg
- Opening through 180°
- Centered pivot-point, possible swing door
- High quality finishes
- Tested according to the standard EN 1670 grade 5
- 5 years warranty
- For 8 and 10 mm thick toughened glass
- For notch 3760BE
- Supplied with screws and spacers.
- Sales unit : Single hinge packaging : 2
Glass to glass hinge packaging : 1

LES + PRODUITS

The + product

Vis et platine
intégralement
cachées pour
une esthétique
améliorée

Réglage précis
de l'angle
de la porte

Grande qualité
de finitions

Système anti-bruit

*Screw and plate
cover for improved
aesthetic*

*Precise adjustment
of the door angle*

High quality finishes

Anti-noise system



**SYSTÈMES BREVETÉS
PATENTED SYSTEM**

- Système de réglage d'angle précis
- Système anti-bruit
- *Adjustment System of the door angle*
- *Anti-noise system*

3760..ORSQCV**

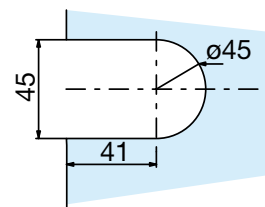

3760BE

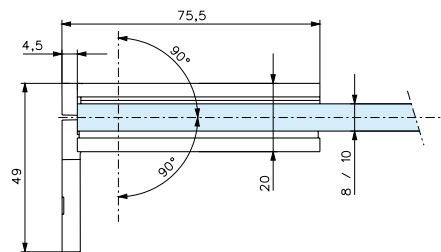
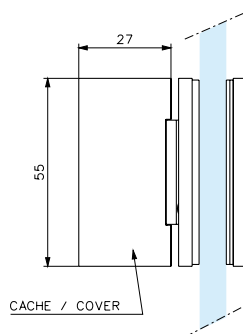
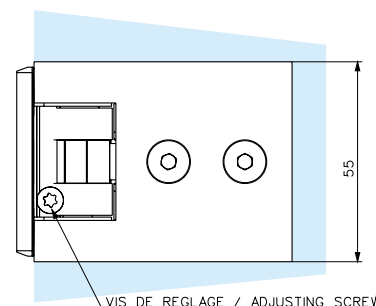
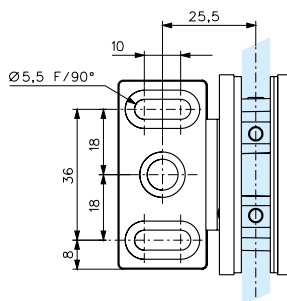

Charnière simple réglable blocage à 90°, 3 trous de fixation
Single adjustable hinge 90° blocking with 3 fixing points

3760.30.ORSQCV 3760.31.ORSQCV

3762.**.ORSQ

Charnières réglables pour pare douche
Adjustable hinges for shower screens

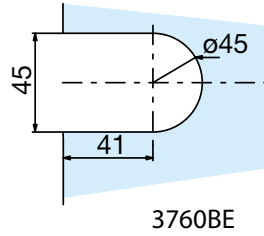

3760BE

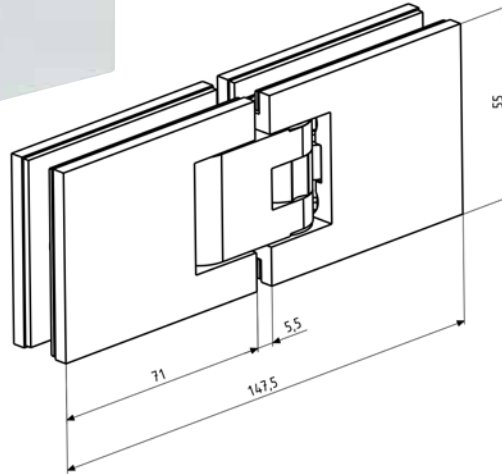

Chromé brillant
Bright chromium



Chromé mat
Matt chromium

Charnière double verre/verre réglable blocage à 90°
Glass to glass adjustable shower hinge 90° blocking point

3762.30.ORSQ 3762.31.ORSQ

3764.**.ORSQ

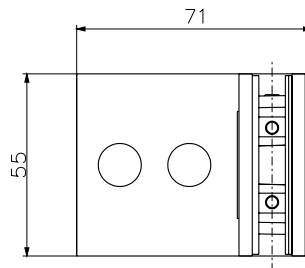
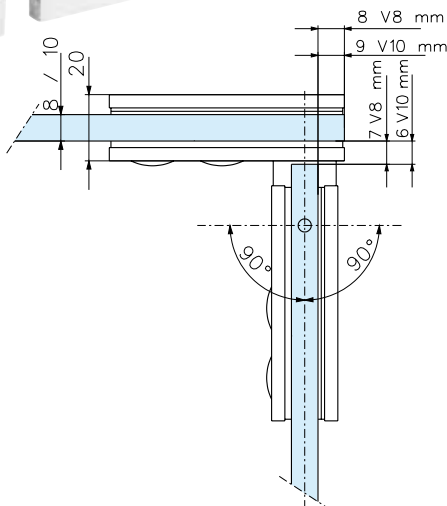
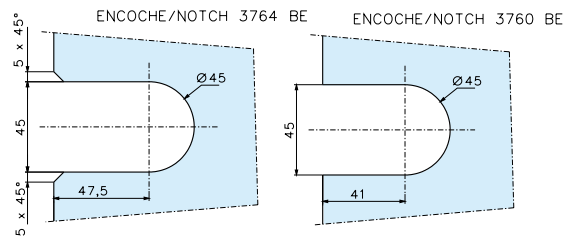
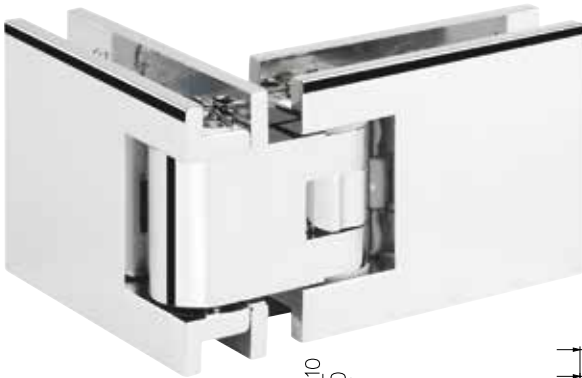

Chromé brillant
Bright chromium



Chromé mat
Matt chromium

Charnière double d'angle 90° réglable
Glass to glass adjustable shower hinge 90° blocking point

3764.30.ORSQ 3764.31.ORSQ

Charnières pour
pare douches
*Hinges for
shower screens*

Maréva

Caractéristiques techniques

- Platine avec trous oblongs pour un réglage en profondeur
- Vis et platine intégralement cachées pour une esthétique améliorée
- Systèmes brevetés
- Réglage précis de l'angle de la porte breveté
- Système anti-bruit breveté
- Pour porte jusqu'à 40kg
- Ouverture à 180°
- Point de rotation centré, va et vient possible
- Grande qualité de finitions
- Testé suivant la norme EN 1670 grade 5
- Garantie 5 ans
- Pour verre trempé de 6 et 8 mm
- Montage sur encoche 3160BE
- Livrée avec vis de fixation
- Unité de vente : Charnière simple, conditionnée par 2
Charnière double, conditionnée par 1

Technical features

- Plate with slotted holes allowing depth adjustment
- Screw and plate cover for improved aesthetic
- Patented system
- Patented precise adjustment of the door angle
- Patented anti-noise system
- For doors up to 40kg
- Opening through 180°
- Centered pivot-point, possible swing door
- High quality finishes
- Tested according to the standard EN 1670 grade 5
- 5 years warranty
- For 6 and 8 mm thick toughened glass
- For notch 3160BE
- Supplied with screws and spacers.
- Sales unit : Single hinge packaging : 2
Glass to glass hinge packaging : 1



LES + PRODUITS

The + product

Vis et platine
intégralement
cachées pour
une esthétique
améliorée

Réglage précis de
l'angle de la porte

Grande qualité
de finitions

Compact

Certifié TUV

Système anti-bruit

*Screw and plate
cover for improved
aesthetic*

*Precise adjustment
of the door angle*

High quality finishes

Compact

TUV certified

Anti-noise system



SYSTÈMES BREVETÉS PATENTED SYSTEM

- Système de réglage d'angle précis
- Système anti-bruit
- *Adjustment System of the door angle*
- *Anti-noise system*

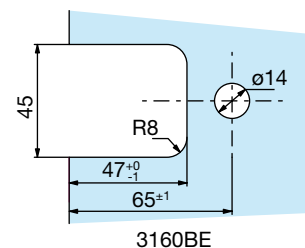

3160.**.ORCV

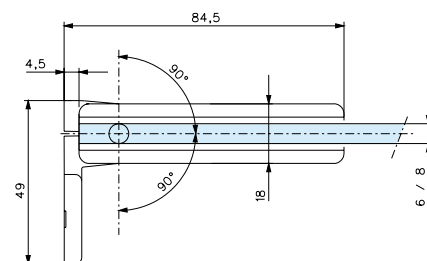
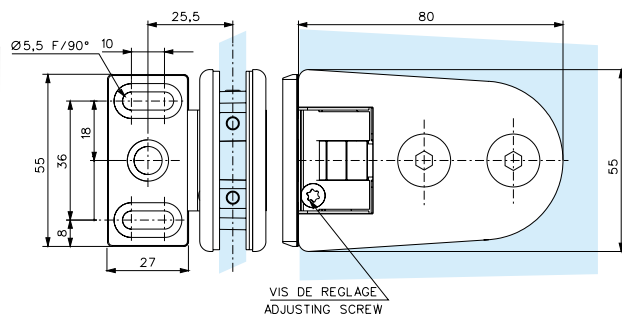

Références / References

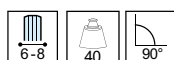

Laiton poli PVD
Polished brass PVD



Chromé brillant
Bright chromium



Chromé mat
Matt chromium



Effet Inox
Stainless steel effect



Laqué blanc 9010
Lacquered white RAL9010

Charnière simple réglable blocage à 90°, **3160.05.ORCV** **3160.30.ORCV** **3160.31.ORCV** **3160.35.ORCV** **3160.51.ORCV**
2 trous de fixation

*Single adjustable hinge 90° blocking
with 2 fixing points*

3161.**.0R

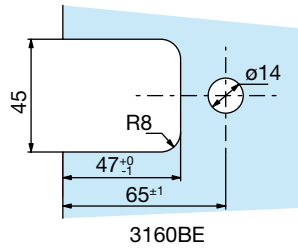

Charnières pour
pare douches
*Hinges for
shower screens*

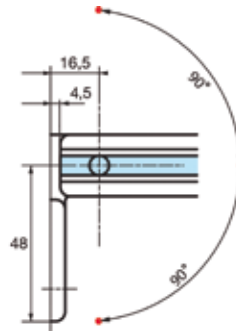
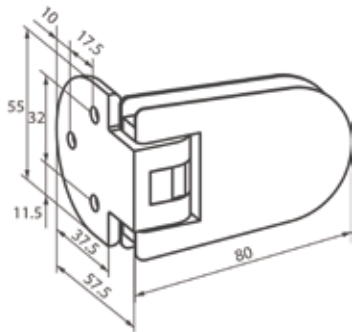

Références / References



- Laiton poli PVD
Polished brass PVD
- Chromé brillant
Bright chromium
- Chromé mat
Matt chromium
- Effet Inox
Stainless steel effect
- Laqué blanc 9010
Lacquered white RAL 9010

Charnière simple réglable blocage à 90° 3161.05.0R 3161.30.0R 3161.31.0R 3161.35.0R 3161.51.0R
3 trous de fixation
*Single adjustable hinge 90° blocking
with 3 fixing points*

3162.**.0R

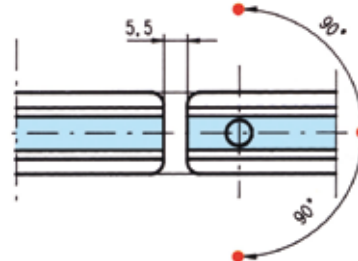
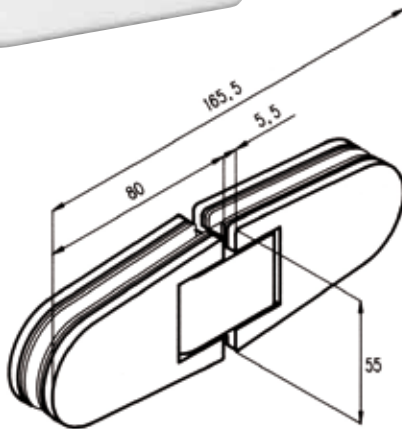
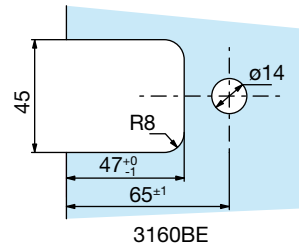

Références / References



- Laiton poli PVD
Polished brass PVD
- Chromé brillant
Bright chromium
- Chromé mat
Matt chromium
- Effet Inox
Stainless steel effect
- Laqué blanc 9010
Lacquered white RAL 9010

Charnière double verre/verre réglable blocage à 90° 3162.05.0R 3162.30.0R 3162.31.0R 3162.35.0R 3162.51.0R
*Glass to glass adjustable
shower hinge 90° blocking point*

Charnières pour
pare douches
Hinges for
shower screens

3162.**.2R

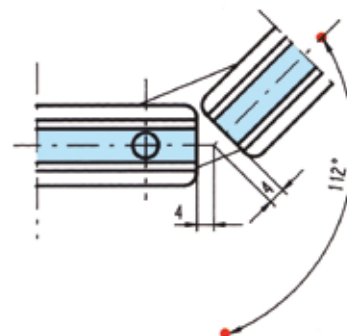
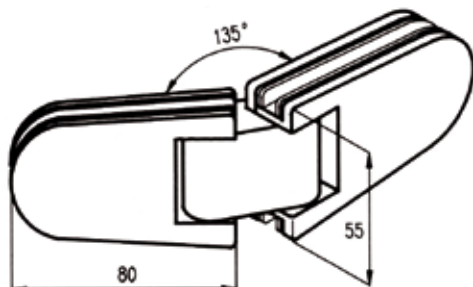
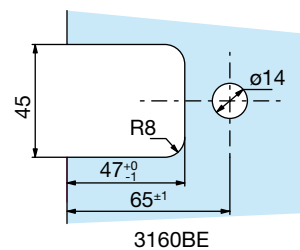

Références / References

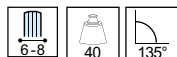

Laiton poli PVD
Polished brass PVD



Chromé brillant
Bright chromium



Chromé brillant
Bright chromium



Effet Inox
Stainless steel effect



Laqué blanc 9010
Lacquered white RAL 9010

Charnière double verre/verre réglable
blocage à 135°
Glass to glass adjustable shower
hinge 135° blocking point

3162.05.2R

3162.30.2R

3162.31.2R

3162.35.2R

3162.51.2R

3163.**.0R

Caractéristiques techniques

- Permet de replier le 2ème volume sur le 1er volume

Technical features

- Enables 2nd glass panel to be folded back over 1st panel

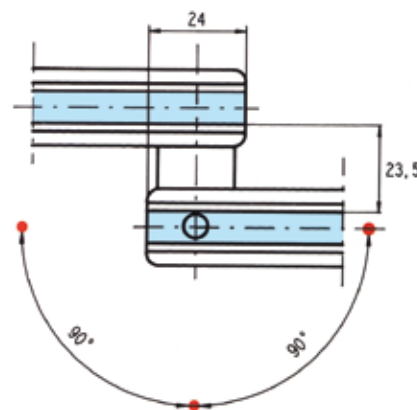
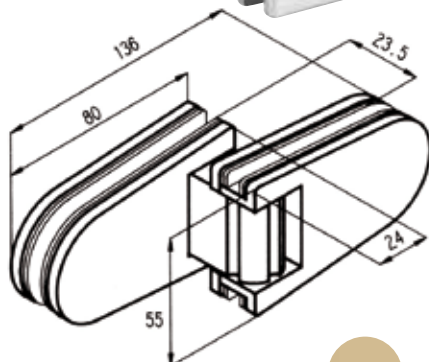
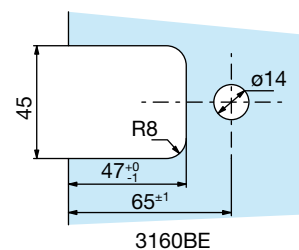

Références / References

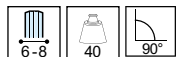

Laiton poli PVD
Polished brass PVD



Chromé brillant
Bright chromium



Chromé mat
Matt chromium



Effet Inox
Stainless steel effect



Laqué blanc 9010
Lacquered white RAL 9010

Charnière double verre/verre réglable,
à recouvrement
Overlapping glass to glass adjustable
shower hinge

3163.05.0R

3163.30.0R

3163.31.0R

3163.35.0R

3163.51.0R

3164.**.0R

Charnières pour pare douches *Hinges for shower screens*

Caractéristiques techniques

- Montage sur encoche 3164BE pour le volume mobile et 3160BE pour le volume fixe

Technical features

- For mobile panel on notch 3164BE, for fixed panel 3160BE

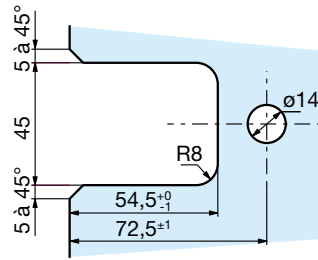
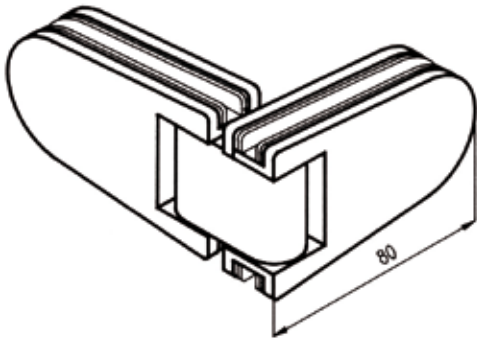

3164BE

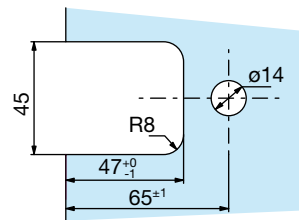
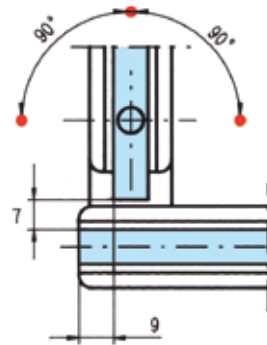

3160BE

Références / References



Laiton poli PVD
Polished brass PVD



Chromé brillant
Bright chromium



Chromé mat
Matt chromium



Effet Inox
Stainless steel effect



Laqué blanc 9010
Lacquered white RAL 9010

Charnière double verre/verre
réglable, à recouvrement
*Overlapping glass to glass adjustable
shower hinge*

3164.05.0R

3164.30.0R

3164.31.0R

3164.35.0R

3164.51.0R

Cales pour
charnières
Shims for hinges

Caractéristiques techniques

- Cas d'utilisation avec les joints translucides séries 1801, 1806 ou pour compenser l'épaisseur de la faïence en partie haute
- Unité de vente : 10 cales

Technical features

- Recommended in conjunction with translucent sealing strips 1801, 1806 or to compensate the thickness of tiles on top part of wall
- Sold by 10

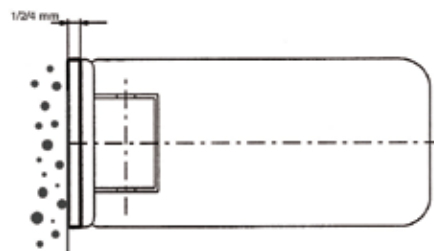
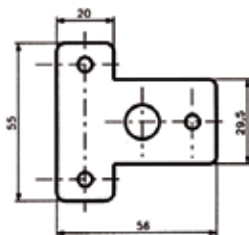

2814..1**

Références / References

10 cales épaisseur 4 mm pour charnière pour série 3261
10 shims, 4 mm thick for hinge series 3261



Chromé brillant
Bright chromium



Chromé mat
Matt chromium

2814.30.1

2814.31.1

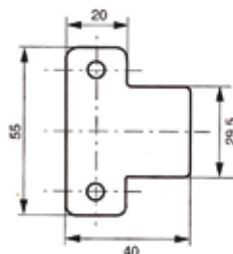

2814..2**

Références / References

10 cales épaisseur 4 mm pour charnière pour série 3660
10 shims, 4 mm thick for hinge series 3660



Chromé brillant
Bright chromium



Chromé mat
Matt chromium

2814.30.2

2814.31.2

2814.99.3

Références / References

10 cales épaisseur 1 mm pour charnières pour séries 3261
10 shims, 1 mm thick for hinge series 3261

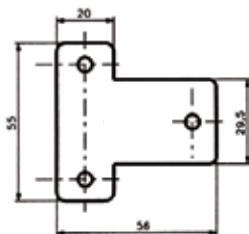

2814.99.4

Références / References

10 cales épaisseur 2 mm pour charnières pour séries 3261
10 shims, 2 mm thick for hinge series 3261

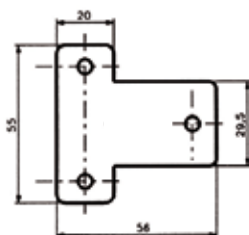



2814.**.7

Références / References

10 cales épaisseur 4 mm pour charnière pour série 3161
10 shims, 4 mm thick for hinge series 3161

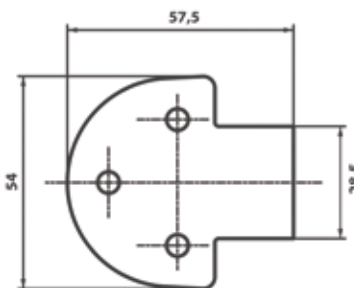

Chromé brillant
Bright chromium



Chromé mat
Matt chromium

2814.30.7

2814.31.7

2814.99.5

Références / References

10 cales épaisseur 1 mm pour charnières pour série 3161
10 shims, 1 mm thick for hinge series 3161

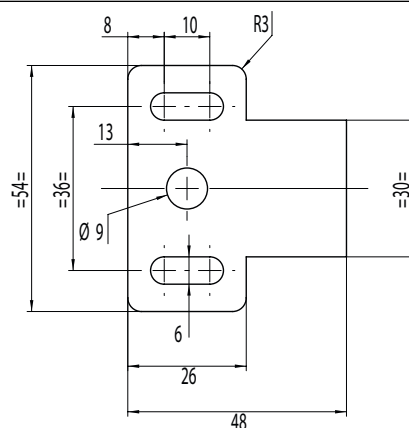
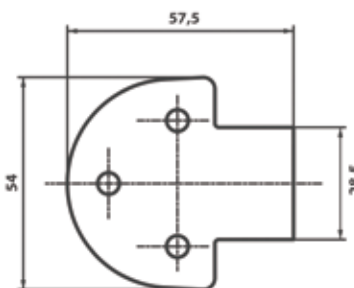

2814.99.3CV

Références / References

10 cales épaisseur 1 mm pour charnière série 3160CV - 3260CV et 3760CV
10 shims, 1 mm thick for hinge series 3160CV - 3260CV and 3760CV

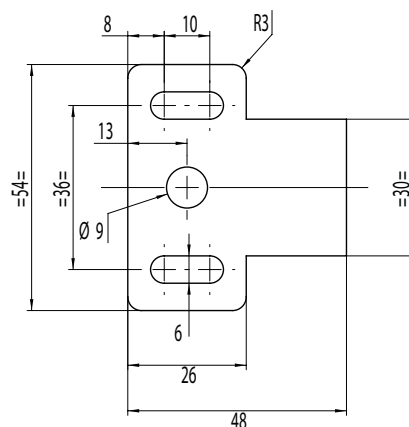

2814.99.4CV

Références / References

10 cales épaisseur 2 mm pour charnière série 3160CV - 3260CV et 3760CV
10 shims, 2 mm thick for hinge series 3160CV - 3260CV and 3760CV

Charnières pour
pare douches
*Hinges for
shower screens*

Coralia

Caractéristiques techniques générales

- Poids maxi par porte 25 kg
- Pour verre trempé de 6 et 8 mm
- Montage sur trous
- Ouverture à 90°
- Livrée avec vis de fixation et intercalaires
- Unité de vente : 1 charnière, conditionnée par 2

General technical features

- Maximum weight per door 25 kg
- For 6 and 8 mm thick toughened glass
- Assembled onto holes
- Opening through 90°
- Supplied with screws and spacers
- Sold per unit, packed in pairs

3060.**.0

Caractéristiques techniques

- Montage sur encoche 3060E
- Blocage du volume par joints magnétiques
- Ouverture possible jusqu'à 170°

Technical features

- For notch 3060E
- Glass door panel blocking by magnetic strips
- Opening through 170°

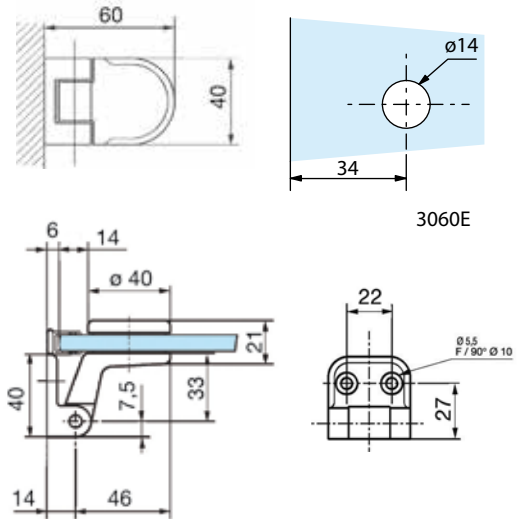

Références / References

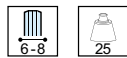

Charnière simple action à
2 trous de fixation
*Single hinge with 2 fixing points,
without blocking point*

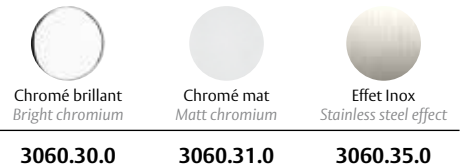

3060.30.0

3060.31.0

3060.35.0

LES + PRODUITS

The + product

Grande qualité
de finitions

3060 et 3063
compatible verre
bombée

Discret

Certifié TUV

High quality finishes

3060 and 3063
compatible with
curved glass

Discreet

TUV certified

3069.**.0

Caractéristiques techniques

- Montage sur encoche 3069E
- Utilisation avec joints bourrelets et joints magnétiques

Technical features

- For notch 3069E
- Used with compressible profile and magnetic sealing strips

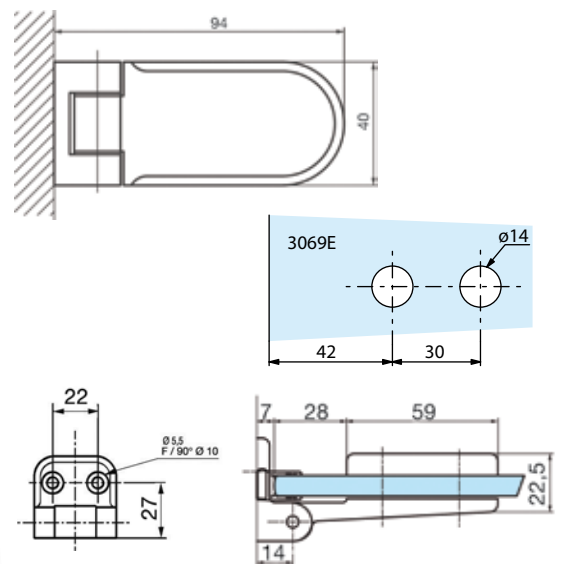

Références / References



Charnière simple action
à 2 trous de fixation
*Single hinge with 2 fixing points,
without blocking point*



3069.30.0

3069.31.0

3069.35.0

3062.**.0

Caractéristiques techniques

- Montage sur encoche 3062E180 pour 2 volumes à 180°
- Montage sur encoche 3062E135 pour 2 volumes à 135°
- Utilisation avec joints bourrelets et joints magnétiques

Technical features

- 180° blocking point 2 glass panels see notch 3062E180
- 135° blocking point 2 glass panels see notch 3062E135
- Used with compressible profile and magnetic sealing strips

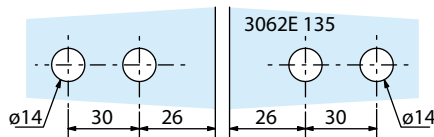
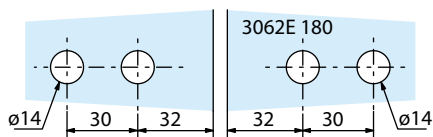
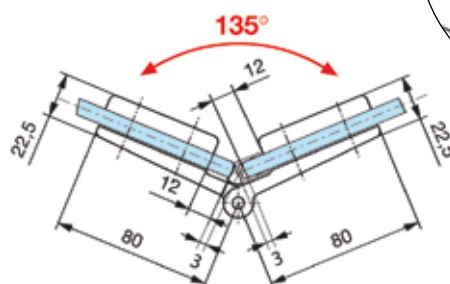
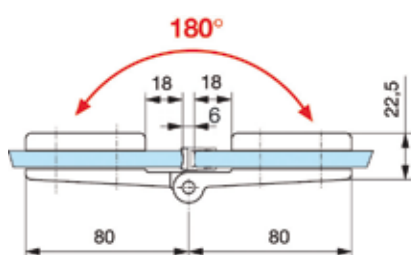
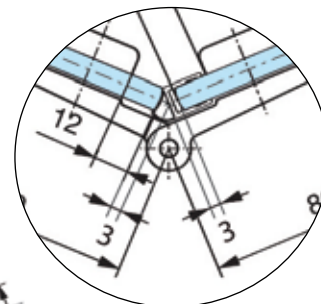
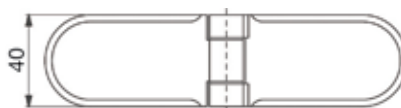

Références / References



Chromé brillant
Bright chromium



Chromé mat
Matt chromium



Effet Inox
Stainless steel effect

Charnière double,
simple action
Glass to glass shower hinge,
one way opening

3062.30.0

3062.31.0

3062.35.0

Charnières pour
pare douches
*Hinges for
shower screens*

Coralia SQ

Caractéristiques techniques

- Poids maxi par porte 25 kg
- Pour verre trempé de 6 et 8 mm (non fourni)
- Montage sur trous
- Ouverture à 90°
- Livrée avec vis de fixation et intercalaires
- Unité de vente : 1 charnière, conditionnée par 2

Technical features

- Maximum weight per door 25 kg
- For 6 and 8 mm thick toughened glass (not supplied)
- Assembled onto holes
- Opening through 90°
- Supplied with screws and spacers
- Sold per unit packed in pairs

3069.**.0SQ

Caractéristiques techniques

- Montage sur encoche 3069E
- Utilisation avec joints bourrelets et joints magnétiques

Technical features

- For notch 3069E
- Used with compressible profile and magnetic sealing strips

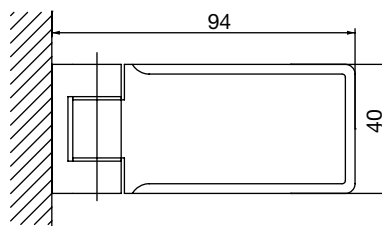

LES + PRODUITS

The + product

Design

Certifié TUV

Design

TUV certified

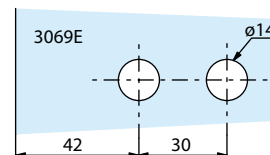
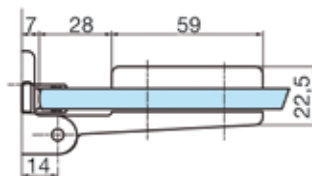
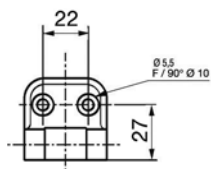

Références / References



Chromé brillant
Bright chromium



Effet Inox
Stainless steel effect

Charnière simple action à 2 trous de fixation
Single hinge with 2 fixing points, without blocking point

3069.30.0SQ

3069.35.0SQ

3062.**.0SQ

Caractéristiques techniques

- Montage sur encoche 3062E180 pour 2 volumes à 180°
- Montage sur encoche 3062E135 pour 2 volumes à 135°
- Utilisation avec joints bourrelets et joints magnétiques

Technical features

- 180° blocking point 2 glass panels see notch 3062E180
- 135° blocking point 2 glass panels see notch 3062E135
- Used with compressible profile and magnetic sealing strips

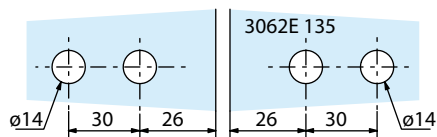
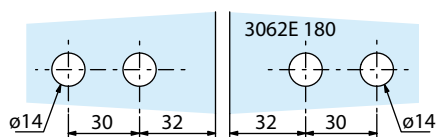
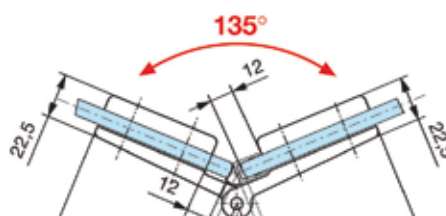
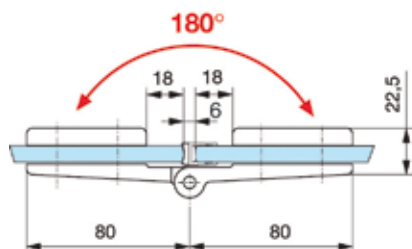
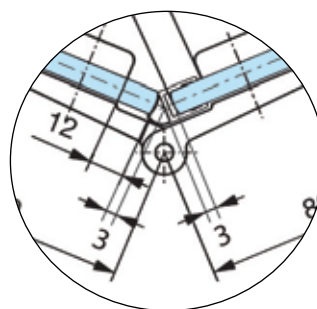
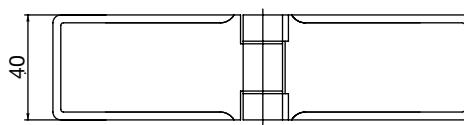

Références / References



Chromé brillant
Bright chromium



Effet Inox
Stainless steel effect

Charnière double, simple action
Glass to glass shower hinge, one way opening

3062.30.0SQ

3062.35.0SQ

Tableau
de synthèses pour
charnières
de douche
*Technical feature
table for shower
hinges*



Marine

Marine SQ

Carrée

Maréva

Mélora

Esthétique / Design

Forme rectangulaire horizontale <i>Rectangular horizontal shape</i>	●	●			
Forme arrondie horizontale <i>Rounded horizontal shape</i>				●	
Forme rectangulaire verticale <i>Rectangular vertical shape</i>					●
Formes carrée ou spécifique <i>Square or specific shapes</i>			●		
Cache vis et platine <i>Screw and plate cover</i>	●	●	●	●	
Accessoires assortis (boutons, pièces fixations) <i>Matching accessories (knobs, partition clips)</i>	●	●	●	●	●

Fonctions / Functions

Charnière simple <i>Glass to wall hinge</i>	●	●	●	●	●
Charnière double à 135° <i>Glass to glass hinge at 135°</i>	●			●	●
Charnière double à 180° <i>Glass to glass hinge at 180°</i>	●	●	●	●	●
Charnière double à recouvrement <i>Glass to glass hinge overlapping</i>				●	
Charnière double d'angle <i>Glass to glass hinge corner</i>	●		●	●	

Finitions / Finish

Chromé-Brillant / <i>Bright chromium</i>	●	●	●	●	●
Chromé-Mat / <i>Matt chromium</i>	●	●	●	●	●
Effet inox / <i>Stainless steel effect</i>	●			●	●
Laqué Blanc 9010 <i>Lacquered RAL 9010</i>	●			●	
PVD / <i>PVD</i>	●			●	●

Fonctionnalités / Features

Système d'indexage <i>Indexing system</i>	●	●	●	●	●
Système levant / <i>Rising system</i>					
Système anti bruit breveté <i>Anti noise patented system</i>	●	●	●	●	●
Réglage d'angle / <i>Angle adjustment</i>	●	●	●	●	●
Réglage platine de fixation <i>Fixing plate adjustment</i>	●	●	●	●	
Fonction va-et-vient / <i>Swing function</i>	●	●	●	●	●

Technique / Technical characteristic

Compatible joint sur hauteur de porte <i>Possibility to fit seal on the length of door</i>					
Poids maxi / volume verrier <i>Maximum weight / glass panel</i>	60 kg	60 kg	45 kg	40 kg	60 kg
Épaisseur verre / <i>Thickness of glass</i>	8-10 mm	8-10 mm	8-10 mm	6-8 mm	8-10-12 mm
Encoche à trous / <i>Hole shaped notches</i>					
Encoche ouvertes / <i>Open notches</i>	●	●	●	●	●

3560SQ



Mélora SQ

3470



Kubika

3060



Coralia

3069



Coralia SQ

Tableau
de synthèses pour
charnières
de douche
*Technical feature
table for shower
hinges*

			●
		●	
●	●		
	●		
●	●	●	●
●	●	●	●
●	●	●	●
		●	
●	●	●	●
●	●	●	●
●	●	●	●
●			
●	●		
●	●		
●	●		
●			
	●	●	●
60 kg	45 kg	25 kg	25 kg
8-10-12 mm	8-10 mm	6-8 mm	6-8 mm
	●	●	●
●			

Pièces de fixation pour volumes fixes de douches
Partition clips for fixed shower screens

3265.**.0

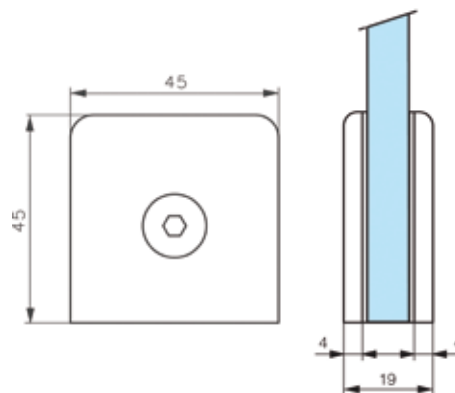
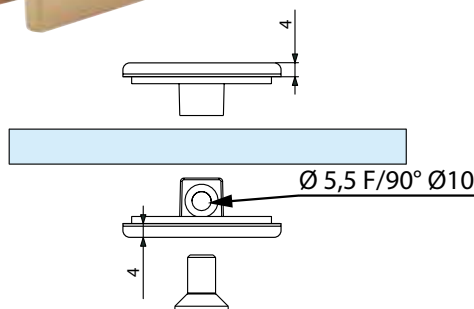
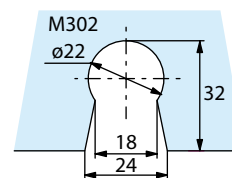

LES + PRODUITS

The + product

3565 :
 installation sur muret

3565 :
 For installation on low wall

Références / References



Laiton poli PVD
 Polished brass PVD



Chromé brillant
 Bright chromium



Chromé mat
 Matt chromium



Effet inox
 Stainless steel effect



Laqué Blanc 9010
 Lacquered white RAL9010

Pièce de fixation pour volume fixe
Partition clip for fixed panel

3265.05.0

3265.30.0

3265.31.0

3265.35.0

3265.51.0

3265.**.0SQ

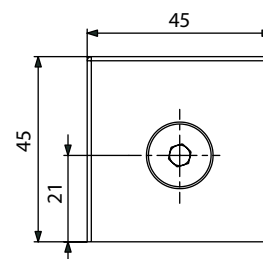
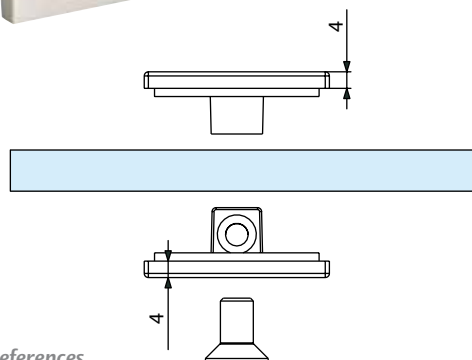
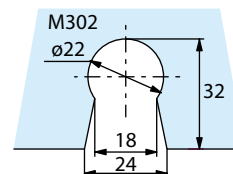

Références / References



Chromé brillant
 Bright chromium



Chromé mat
 Matt chromium



Effet inox
 Stainless steel effect

Pièce de fixation pour volume fixe
Partition clip for fixed panel

3265.30.0SQ

3265.31.0SQ

3265.35.0SQ

3465.**.0

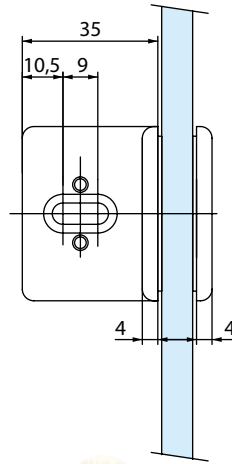
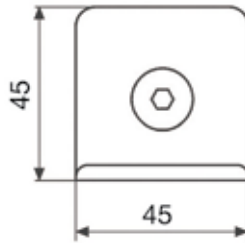
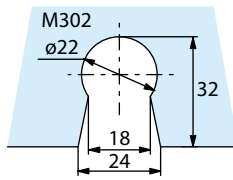

Pièces de fixation pour volumes fixes de douches
Partition clips for fixed shower screens

Références / References



Laiton poli PVD Polished brass PVD	Chromé brillant Bright chromium	Chromé mat Matt chromium	Effet inox Stainless steel effect	Laqué Blanc 9010 Lacquered white RAL 9010

Pièce de fixation avec équerre pour volume fixe
Partition clip for fixed panel

3465.05.0

3465.30.0

3465.31.0

3465.35.0

3465.51.0

3565.**.0

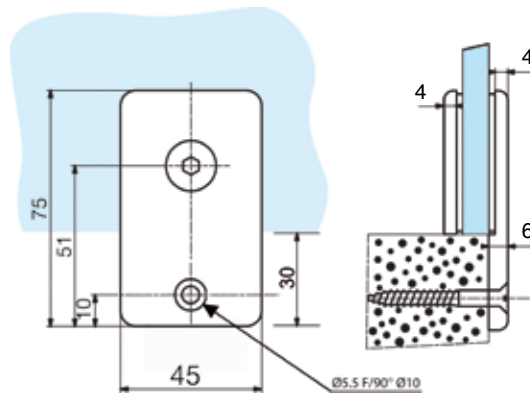
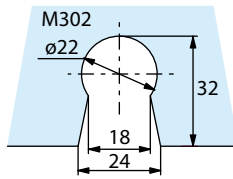

Références / References



Laiton poli PVD Polished brass PVD	Chromé brillant Bright chromium	Chromé mat Matt chromium	Effet inox Stainless steel effect	Laqué Blanc 9010 Lacquered white RAL 9010

Pièce de fixation pour volume fixe sur muret
Partition clip for fixed panel assembly onto low wall

3565.05.0

3565.30.0

3565.31.0

3565.35.0

3565.51.0

Pièces de fixation pour volumes fixes de douches
Partition clips for fixed shower screens

3165.**.0

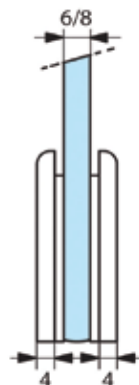
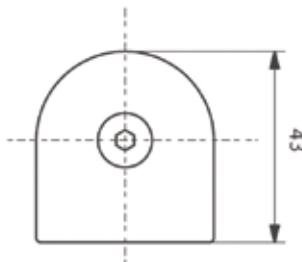
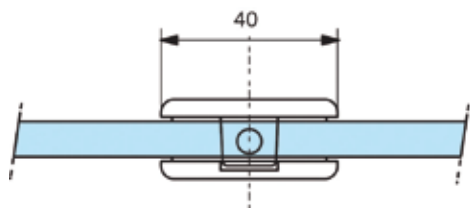
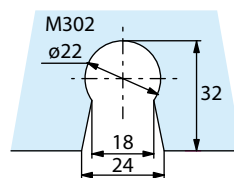

Références / References



Laiton poli PVD
 Polished brass PVD



Chromé brillant
 Bright chromium



Chromé mat
 Matt chromium



Effet inox
 Stainless steel effect



Laqué Blanc 9010
 Lacquered white RAL 9010

Pièce de fixation pour volume fixe
Partition clip for fixed panel

3165.05.0

3165.30.0

3165.31.0

3165.35.0

3165.51.0

3085.**.0

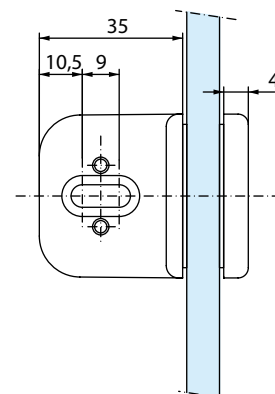
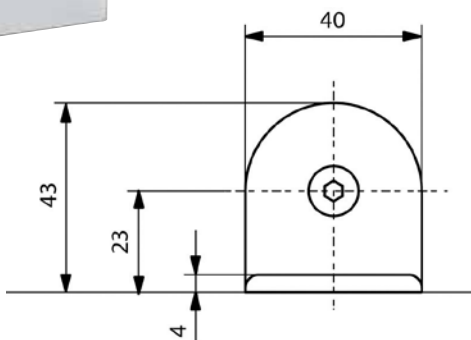
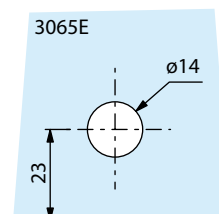
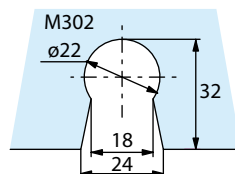

Références / References



Chromé brillant
 Bright chromium



Chromé mat
 Matt chromium



Effet inox
 Stainless steel effect

Pièce de fixation avec équerre pour volume fixe
Partition clip for fixed panel

3085.30.0

3085.31.0

3085.35.0

3065.**.0

Pièces de fixation pour volumes fixes de douches
Partition clips for fixed shower screens

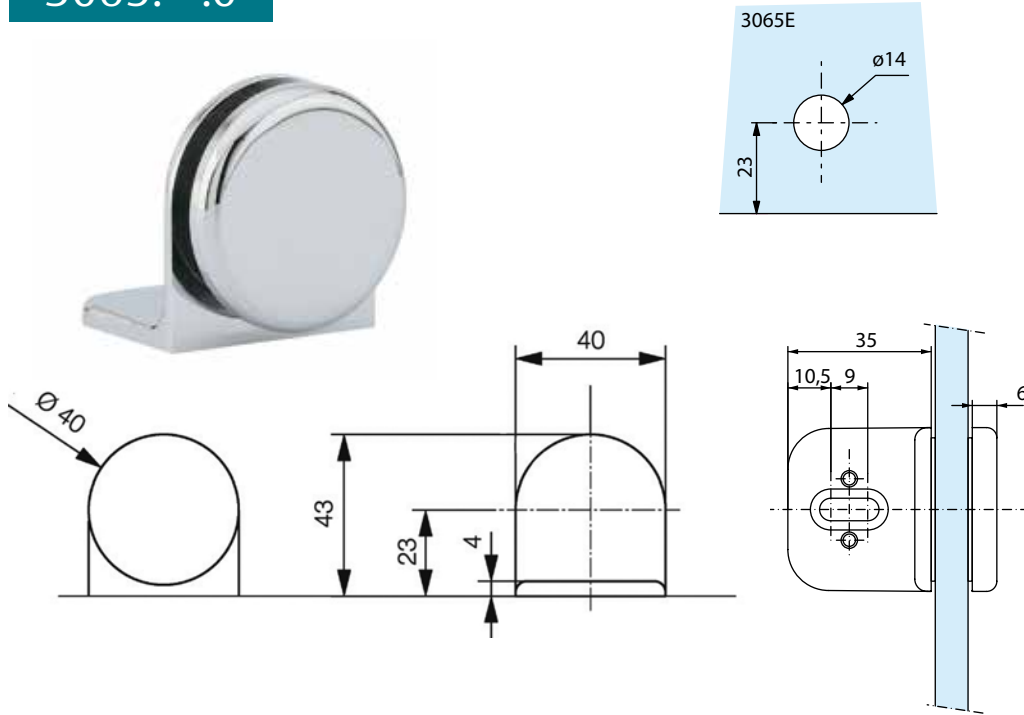

Références / References



Pièce de fixation avec équerre pour volume fixe
Partition clip for fixed panel

3065.30.0 3065.31.0 3065.35.0

3056.**.0

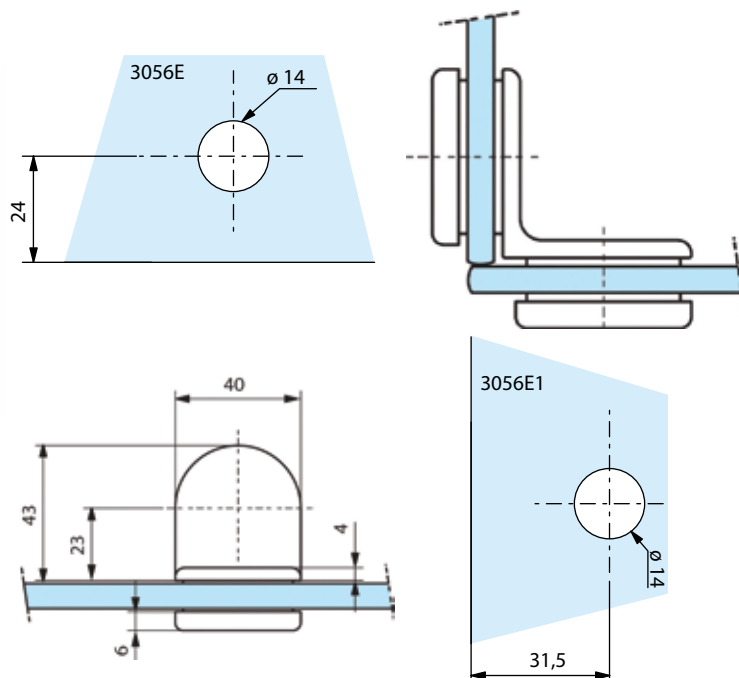

Références / References



Pièce de liaison d'angle pour 2 volumes fixes à 90°
Corner partition clip for fixed panels at 90°

3056.30.0 3056.31.0 3056.35.0

- Pose au milieu de volume
- Montage sur encoches 3056E et 3056E1

- Assembled in the middle of the panel
- To be assembled on notches 3056E and 3056E1

Pièces de fixation pour volumes fixes de douches
Partition clips for fixed shower screens

3255.**.0

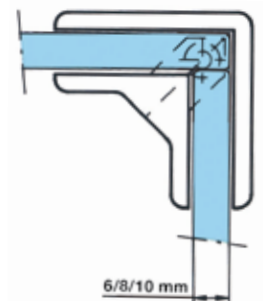
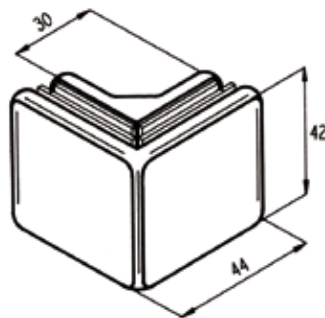
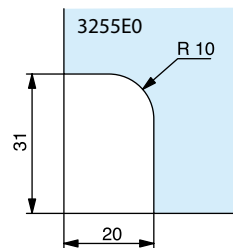

Références / References



Chromé brillant
Bright chromium



Chromé mat
Matt chromium

Pièce de fixation haute ou basse pour 2 volumes fixes à 90°
Corner partition clip for fixed panels at 90°

3255.30.0

3255.31.0

- Pose aux extrémités du volume
- Montage sur encoches 3255E0

- Assembled at the edge of the glass
- To be assembled on notches 3255E0

3256.**.0

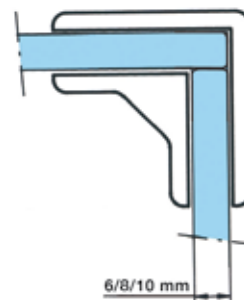
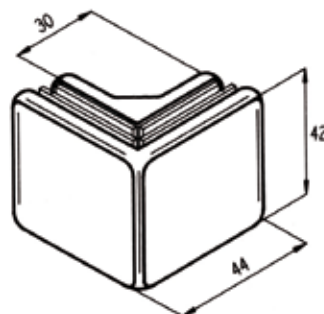
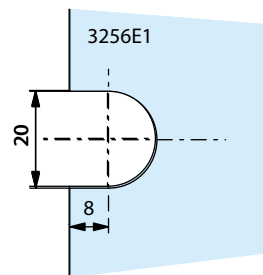

Références / References



Laiton poli PVD
Polished brass PVD



Chromé brillant
Bright chromium



Chromé mat
Matt chromium



Effet inox
Stainless steel effect



Laqué Blanc 9010
Lacquered white RAL 9010

Pièce de liaison d'angle pour 2 volumes fixes à 90°
Corner partition clip for fixed panels at 90°

3256.05.0

3256.30.0

3256.31.0

3256.35.0

3256.51.0

- Pose au milieu de volume
- Montage sur encoches 3256E1

- Assembled in the middle of the panel
- To be assembled on notches 3256E1

3257.**.0

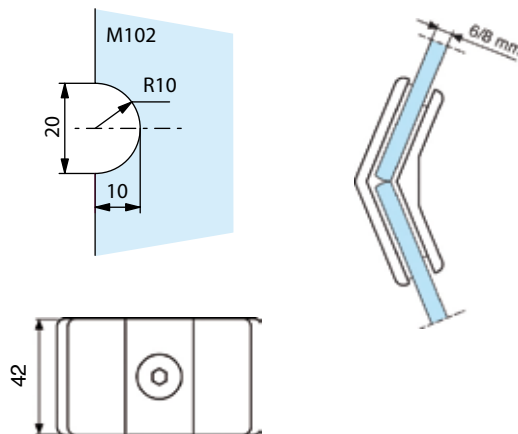

Pièces de fixation pour volumes fixes de douches
Partition clips for fixed shower screens

Références / References



Chromé brillant
Bright chromium



Chromé mat
Matt chromium



Effet inox
Stainless steel effect

Pièce de liaison d'angle pour 2 volumes fixes à 135°
Corner partition clip for fixed panels at 135°

3257.30.0

3257.31.0

3257.35.0

- Pose au milieu de volume
- Montage sur encoches M102

- Assembled in the middle of the panel
- To be assembled on notches M102

3258.**.0

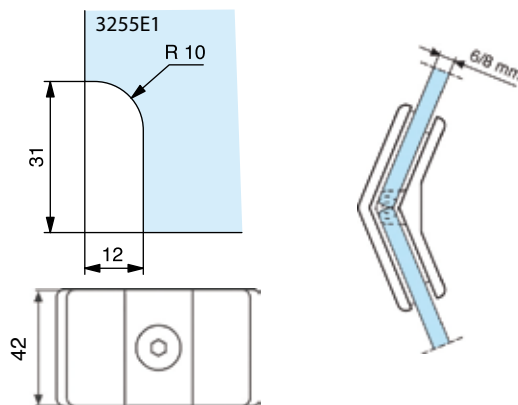

Références / References



Chromé brillant
Bright chromium



Chromé mat
Matt chromium

Pièce de fixation haute ou basse pour 2 volumes fixes à 135°
Corner partition clip for fixed panels at 135°

3258.30.0

3258.31.0

- Pose aux extrémités du volume
- Montage sur encoches 3255E1

- Assembled at the edge of the glass
- To be assembled on notches 3255E1

5506.**.4

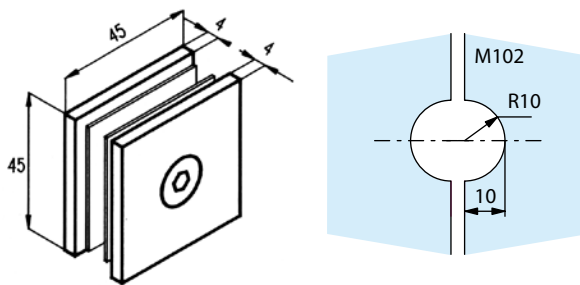

Références / References



Chromé brillant
Bright chromium



Chromé mat
Matt chromium

Pièce de liaison pour 2 volumes fixes
Partition clip for 2 fixed panels

5506.30.4

5506.31.4

- Montage avec encoche M102

- Fits notch M102

Profils de compensation Correcting profiles

Caractéristiques techniques générales

- Pour verre trempé de 6 ou 8 mm (suivant les références)
- Montage sans encoche
- Livrée avec joint pour les réf 2818 et 2817
- Unité de vente : 1 profil

General technical features

- For toughened glass doors 6 or 8 mm
- No notch required
- Supplied with spacers for series 2818 and 2817
- Sold per unit

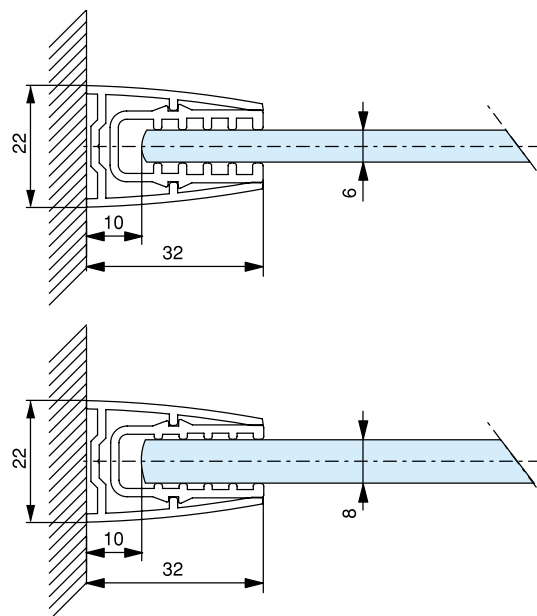

LES + PRODUITS

The + product

Pose facile

Possibilité de réglage

Étanchéité mur/verre

Easy installation

Possible adjustment

Improved waterproofing wall/glass

Références / References

Profil de compensation lg 2200 mm pour volume fixe
Vertical correcting profile length 2200 mm for fixed panel

Alu poli brillant
Polished aluminium

Chromé mat
Matt chromium



2818.13.2

2818.31.2



2818.13.3

2818.31.3

- Fixation du profil par vis TF Ø 4 mm (non fourni)
- Compatibilité avec profil pour receveur série 2819

- Profile assembled with screws TF Ø 4 mm (not supplied)
- Compatible with the profile for shower tray series 2819

2819.***

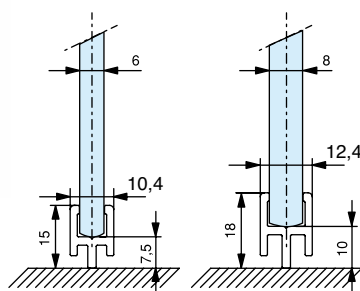

Profils
de compensation
Correcting
profiles

Références / References

Profil bas lg 2200 mm pour volume fixe
Bottom profile length 2200 mm for fixed panel



Alu poli brillant
Polished aluminium



Chromé mat
Matt chromium



2819.13.2

2819.31.2



2819.13.3

2819.31.3

- Profil à clipper sur le verre
- Fixation du profil sur le receveur par 2 joints silicone de chaque côté de la barrette centrale
- Compatible avec profil de compensation série 2818

- Profile clipped onto glass
- Profile fixed onto the tray by 2 silicone seals on each side of central rail
- Compatible with correcting profile series 2818

EM2819.**.3



Chromé brillant
Bright chromium



Chromé mat
Matt chromium

Références / References

10 Embouts de profil pour 2819.xx.3
10 covers for profile 2819.xx.3

EM2819.30.3

EM2819.31.3

- Pour profil bas 2819 épaisseur verre 8 mm uniquement
- For 2819 bottom profile 8 mm thick glass

Barres raidisseurs
pour volumes fixes
*Reinforcement bars
for fixed panels*

Profil raidisseur sol plafond pour paroi fixe

Floor to ceiling support for fixed shower screen

- Obturateur pour la rainure du tube entre le haut du verre et le plafond.
- Fixation au plafond et au sol par vis invisible.
- Montage du verre dans le tube avec joint PVC - Pour Verre trempé ép: 8mm
- Compatible avec le profil bas réf 2819.13.3
- Possibilité d'utilisation avec verre ép 6mm (Joint + silicone)
- Possibilité d'utilisation avec verre ép 10mm (Sans joint uniquement silicone)
- Disponible en Kit de fixation intégrale (réf 2816+2819+2818)

- *Shutter for the opening in the tube between ceiling and glass*
- *Invisible fixing point on the floor and ceiling*
- *Installation of the glass with PVC jointing strip for 8mm tempered glass.*
- *Compatible with bottom profile 2819.13.3*
- *Can be used with 6mm glass (plastic profile +silicone)*
- *Can be used with 10mm glass (only silicone no plastic profile)*
- *Available in full fixing kit (ref 2816+2819/2818)*

Caractéristiques techniques

- Pour verre de 8 mm
- Sans encoche
- Design tube Ø 34mm pour une meilleur rigidité
- Longueur 3000 mm ajustable par recoupe
- Recouvrement de la coupe pour une finition parfaite
- Fixation par 2 vis
- Pose sans silicone
- Hauteur maxi du verre = 2200mm

Technical features

- For 8mm thick toughened glass
- No notch needed
- Design round Ø34mm
- Length of the profile 3000mm can be shortened
- Fixing by 2 screws
- Installation with joint no silicone
- Covering of the cut for a perfect finish
- Max. height of the glass = 2200mm

LES + PRODUITS

The + product

Haute résistance
à la corrosion
(ISO 0227-2007)

Pour volume de
grande hauteur

Montage sans
encoche.

Solution esthétique
de fixation
de volume fixe.

Solution KIT de
fixation intégrale
WPROF02

*Without glass cut-
ting.*

High corrosion
resistance
(ISO 0227-2007)

For high glass panels

Aesthetic solution for
fixed panel.

Available in full fixing
kit WPROF02

2816.13.3

Références / References



Profil raidisseur sol plafond pour paroi fixe
Floor to ceiling support for fixed shower panels



Alu poli brillant
Polished aluminium

2816.13.3

Kits complets / Complete kits

Kit fixation intégrale comprenant 2816 + 2819+ 2818
Full fixing kit composed of 2816+2819+2818

WPROF02/03.13

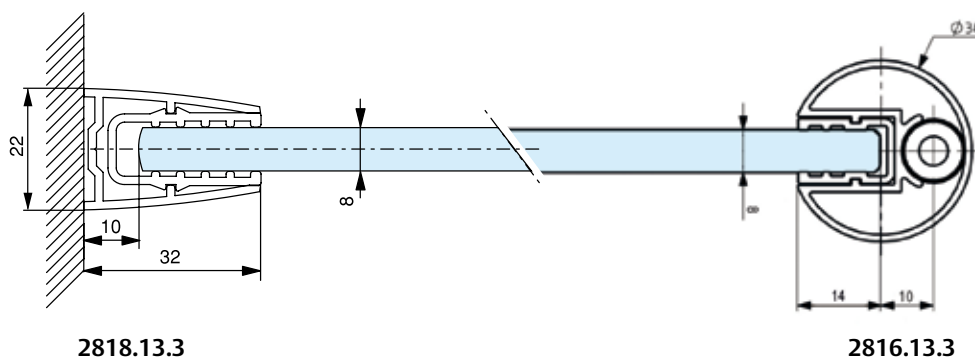

Barres raidisseurs
pour volumes fixes
*Reinforcement bars
for fixed panels*





LES + PRODUITS
The + product

Pas d'encoche

No notch

Profils U et L décor alu poli brillant
U and L profiles Polished aluminium finish



Alu poli brillant
Polished aluminium

Références / References

<p>Profil U 15x15x15x2 mm largeur intérieure 11 mm longueur de 3000 mm <i>U-profile 15x15x15x2 mm 11 mm inside width 3000 mm length</i></p>	U151515.13
<p>Profil U 20x12x20x1,5 mm largeur intérieure 9 mm longueur de 3000 mm <i>U-profile 20x12x20x1,5 mm 9 mm inside width 3000 mm length</i></p>	U201220.13
<p>Profil U 20x15x20x2 mm largeur intérieure 11 mm longueur de 3000 mm <i>U-profile 20x15x20x2 mm 11 mm inside width 3000 mm length</i></p>	U201520.13
<p>Profil U 20x17x20x2 mm largeur intérieure 13 mm longueur de 3000 mm <i>U-profile 20x17x20x2 mm 13 mm inside width 3000 mm length</i></p>	U201720.13
<p>Profil U 20x20x20x2 mm largeur intérieure 16 mm longueur de 3000 mm <i>U-profile 20x20x20x2 mm 16 mm inside width 3000 mm length</i></p>	U202020.13
<p>Profil U 30x20x30x2 mm largeur intérieure 16 mm longueur de 3000 mm <i>U-profile 30x20x30x2 mm 16 mm inside width 3000 mm length</i></p>	U302030.13
<p>Profil U 40x20x40x2 mm largeur intérieure 16 mm longueur de 3000 mm <i>U-profile 40x20x40x2 mm 16 mm inside width 3000 mm length</i></p>	U402040.13
<p>Profil L 15x15x2 mm longueur de 3000 mm <i>L-profile 15x15x2 mm 3000 mm length</i></p>	L1515.13
<p>Profil L 20x20x2 mm longueur de 3000 mm <i>L-profile 20x20x2 mm 3000 mm length</i></p>	L2020.13
<p>Profil L 25x25x2 mm longueur de 3000mm <i>L-profile 25x25x2 mm 3000 mm length</i></p>	L2525.13

Quantités minimum de commande par référence = 5 longueurs

Quantités de lots par référence = 5 longueurs

*Minimum quantity per order and per reference = 5 lengths
Sold in packs per reference = 5 lengths*

1651.**.0

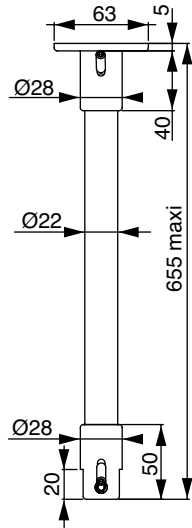
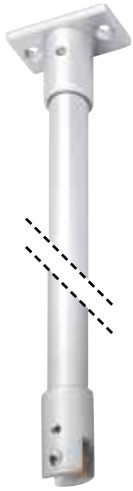

Barres raidisseurs pour volumes fixes
Reinforcement bars for fixed panels

Références / References



Barre raidisseur verre/plafond lg : 635 mm
Reinforcement bar for shower glass/ceiling
635 mm length



Chromé brillant
Bright chromium

1651.30.0



Chromé mat
Matt chromium

1651.31.0



Effet inox
Stainless steel effect

1651.35.0

- Maintien des volumes fixes par pinces et serrage par vis à embout
- Tube de longueur 600 mm ajustable par recoupe

- Fixed panel is held in place by a clip tightened by a plastic tipped screw
- 600 mm length tube modified by cutting down to required size

1657.**.0

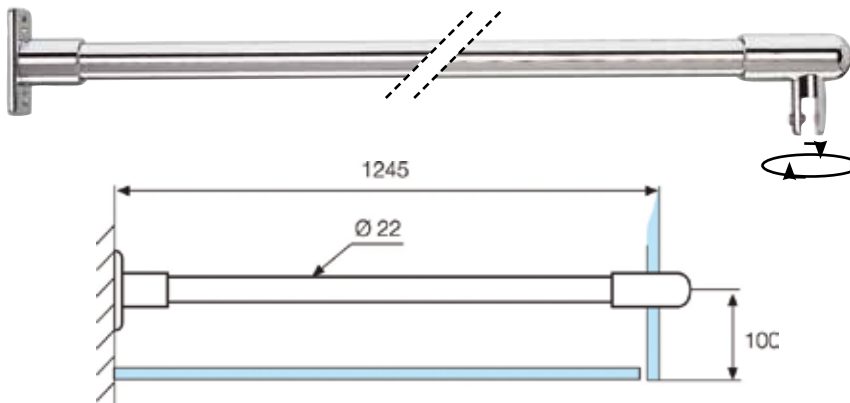

Références / References



Barre raidisseur mur/verre lg 1200 mm
Reinforcement bar for shower glass/wall
1200 mm length



Laiton poli PVD
Polished brass PVD

1657.05.0



Chromé brillant
Bright chromium

1657.30.0



Chromé mat
Matt chromium

1657.31.0



Effet inox
Stainless steel effect

1657.35.0



Laqué blanc 9010
Lacquered white RAL 9010

1657.51.0

- Maintien du volume fixe par pince orientable et serrage par vis à embout
- Tube de longueur 1200 mm ajustable par recoupe
- Montage possible sans la platine

- Fixed panel is held in place by an adjustable clip tightened by a plastic tipped screw
- 1200 mm length tube modified by cutting down to required size
- Possible installation without the plate

ASSA ABLOY

Barres raidisseurs pour volumes fixes
Reinforcement bars for fixed panels

1652.**.0

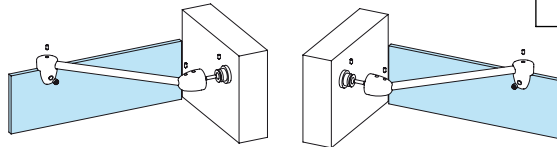
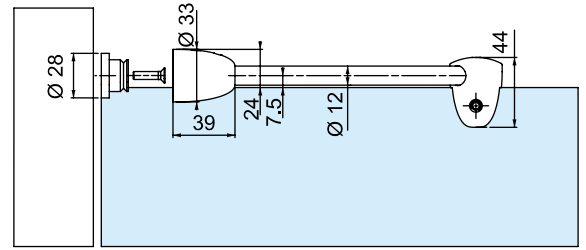
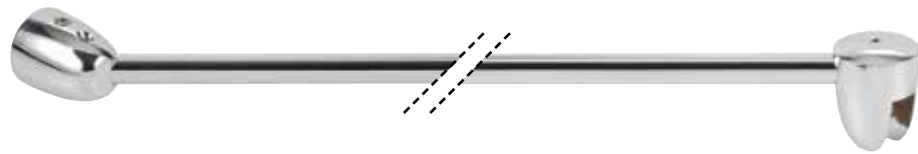

Références / References



Chromé brillant
Bright chromium



Chromé mat
Matt chromium

1652.30.0

1652.31.0

Kit 2 barres raidisseurs d'angle droite et gauche
Kit comprising 2 corner reinforcement bars left and right

- Maintien des volumes fixes par pinces et serrage par vis à embout
- Tube de longueur 500 mm ajustable par recoupe

- Fixed panel is held in place by a clip tightened by a plastic tipped screw
- 500 mm length tube modified by cutting down to required size

LES + PRODUITS

The + product

Ajustable facilement
Gamme complète

Easy adjustment
Complete range

1652.**.0G

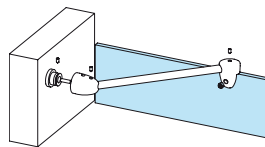

Références / References



Chromé brillant
Bright chromium



Chromé mat
Matt chromium



Effet inox
Stainless steel effect



Laqué blanc 9010
Lacquered white RAL 9010

1652.30.0G

1652.31.0G

1652.35.0G

1652.51.0G

Barre raidisseur d'angle gauche lg 1000 mm
Corner reinforcement bar left 1000 mm length

- Maintien des volumes fixes par pinces et serrage par vis à embout
- Tube de longueur 1000 mm ajustable par recoupe

- Fixed panel is held in place by a clip tightened by a plastic tipped screw
- 1000 mm length tube modified by cutting down to required size

1652.**.0D

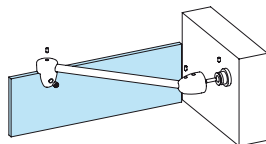

Références / References



Chromé brillant
Bright chromium



Chromé mat
Matt chromium



Effet inox
Stainless steel effect



Laqué blanc 9010
Lacquered white RAL 9010

1652.30.0D

1652.31.0D

1652.35.0D

1652.51.0D

Barre raidisseur d'angle droite lg 1000 mm
Corner reinforcement bar right 1000 mm length

- Maintien des volumes fixes par pinces et serrage par vis à embout
- Tube de longueur 1000 mm ajustable par recoupe

- Fixed panel is held in place by a clip tightened by a plastic tipped screw
- 1000 mm length tube modified by cutting down to required size

1657.**.1

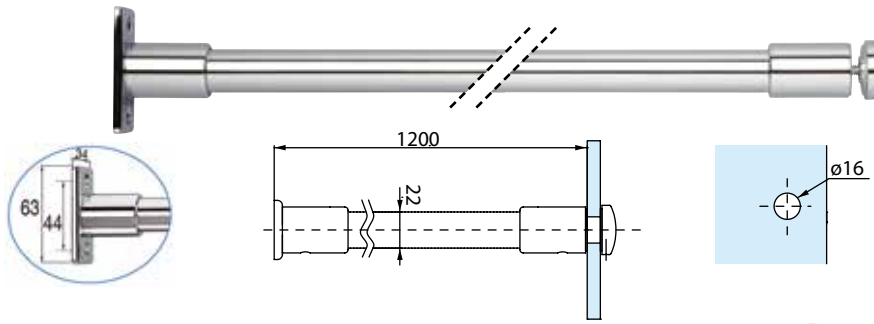

Barres raidisseurs pour volumes fixes
Reinforcement bars for fixed panels

Références / References



Barre raidisseur mur/verre lg 1200 mm
Reinforcement bar for shower glass/wall 1200 mm length

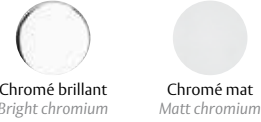

1657.30.1 1657.31.1

- Montage sur le verre trempé avec 1 trou Ø 16 MM
- Tube de longueur 1200 mm ajustable par recoupe
- Montage possible sans la platine
- Mounting hole Ø 16 mm
- 1200 mm length tube modified by cutting down to required size
- Possible installation without the plate

1657.**.2SQ

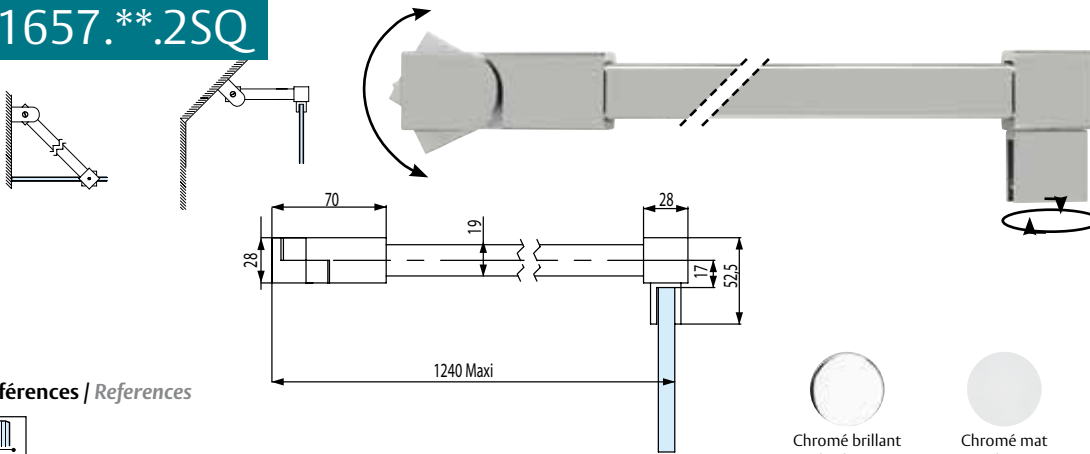

Références / References



Barre raidisseur carrée articulée mur/verre lg 1200 mm
Articulated square reinforcement bar for shower glass/wall 1200 mm length

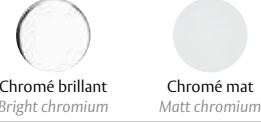

1657.30.2SQ 1657.31.2SQ

- Possibilité de montage en angle ou sous pente avec la platine de fixation orientable
- Maintien du volume fixe par pince orientable et serrage par vis à embout
- Tube de longueur 1200 mm ajustable par recoupe
- Possibility of assembling in a corner or on an incline with an adjustable fixing plate
- Fixed panel is held in place by an adjustable clip tightened by a plastic tipped screw
- 1200 mm length tube modified by cutting down to required size

1657.**.0D12

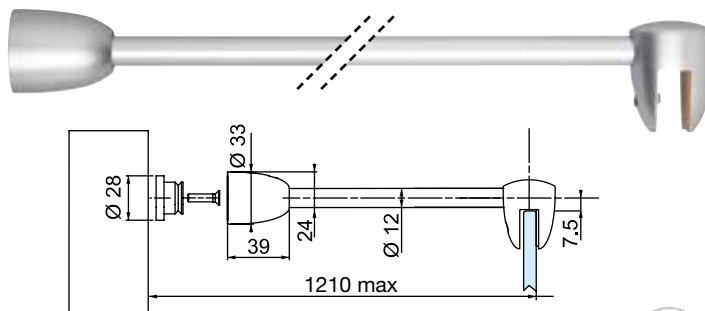

Références / References



Barre raidisseur mur/verre parallèle lg 1200 mm
Reinforcement bar for shower glass/wall 1200 mm length



1657.30.0D12 1657.31.0D12

- Maintien du volume fixe par pince et serrage par vis à embout
- Tube de longueur 1200 mm ajustable par recoupe
- Fixed panel is held in place by a clip tightened by a plastic tipped screw
- 1200 mm length tube modified by cutting down to required size

Barres raidisseurs
pour volumes fixes
Reinforcement bars
for fixed panel

1658.**.0

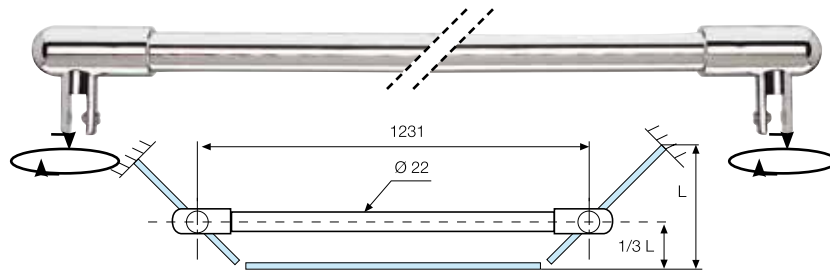

Références / References



Laiton poli PVD
Polished brass PVD



Chromé brillant
Bright chromium



Chromé mat
Matt chromium



Effet inox
Stainless steel effect



Laqué blanc 9010
Lacquered white RAL 9010

Barre raidisseur verre/verre lg 1200 mm
Reinforcement bar for shower glass/glass
1200 mm length

1658.05.0

1658.30.0

1658.31.0

1658.35.0

1658.51.0

- Maintien du volume fixe par pince orientable et serrage par vis à embout • Fixed panel is held in place by an adjustable clip tightened by a plastic tipped screw
- Tube de longueur 1200 mm ajustable par recoupe • 1200 mm length tube modified by cutting down to required size

1658.**.2SQ

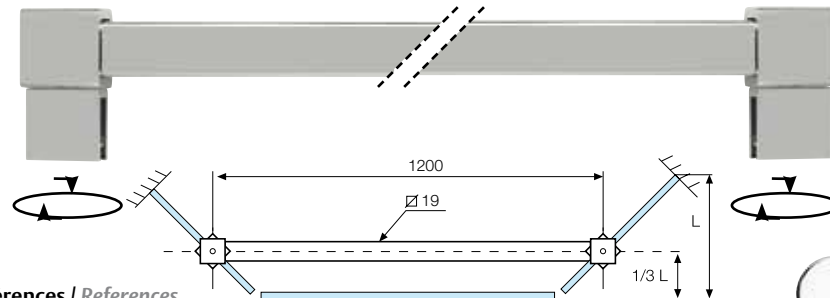

Références / References



Chromé brillant
Bright chromium



Chromé mat
Matt chromium

Barre raidisseur carrée verre/verre lg 1200 mm
Articulated square reinforcement bar for shower glass/glass 1200 mm length

1658.30.2SQ

1658.31.2SQ

- Maintien du volume fixe par pince orientable et serrage par vis à embout
- Tube de longueur 1200 mm ajustable par recoupe
- Fixed panel is held in place by an adjustable clip tightened by a plastic tipped screw
- 1200 mm length tube modified by cutting down to required size

1658.**.0D12

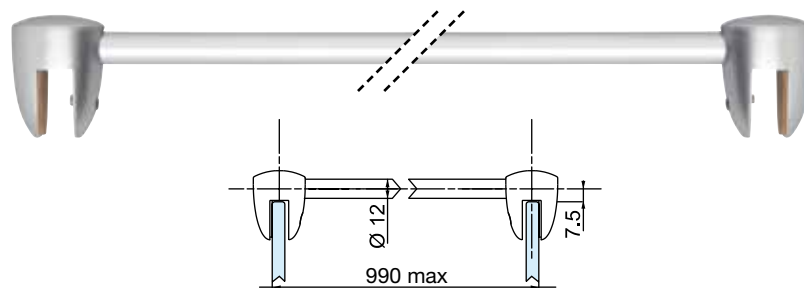

Références / References



Chromé brillant
Bright chromium



Chromé mat
Matt chromium

Barre raidisseur verre/verre parallèle lg 1000 mm
Reinforcement bar for shower glass/glass
1000 mm length

1658.30.0D12

1658.31.0D12

- Maintien du volume fixe par pince et serrage par vis à embout • Fixed panel is held in place by a clip tightened by a plastic tipped screw
- Tube de longueur 1000 mm ajustable par recoupe • 1000 mm length tube modified by cutting down to required size

1658.**.1D12

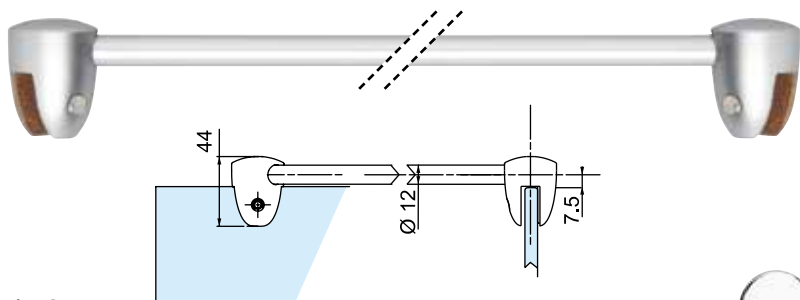

Références / References



Chromé brillant
Bright chromium



Chromé mat
Matt chromium

Barre raidisseur d'angle verre/verre lg 1000 mm
Corner reinforcement bar for shower glass/glass 1000 mm length

1658.30.1D12 1658.31.1D12

- Maintien du volume fixe par pince et serrage par vis à embout
- Tube de longueur 1000 mm ajustable par recoupe

- Fixed panel is held in place by a clip tightened by a plastic tipped screw
- 1200 mm length tube modified by cutting down to required size

1659.**.0

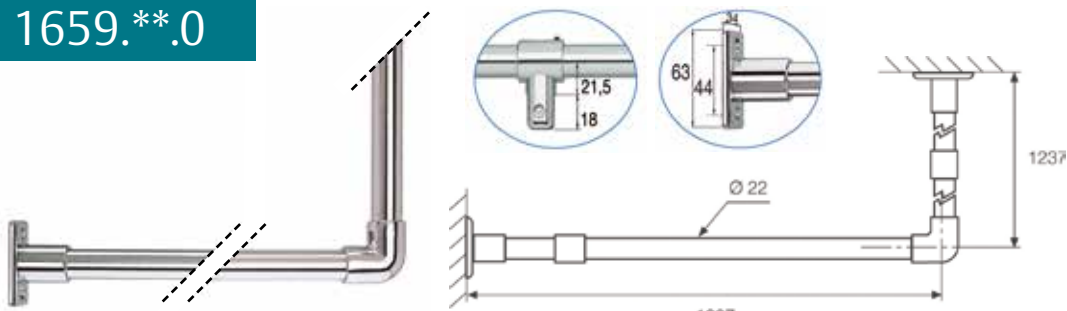

Références / References



Laiton poli PVD
Polished brass PVD



Chromé brillant
Bright chromium



Chromé mat
Matt chromium



Effet inox
Stainless steel effect

Barre raidisseur d'angle lg 1200 mm
Corner reinforcement bar 1200 mm length

1659.05.0 1659.30.0 1659.31.0 1659.35.0

- Maintien des volumes fixes par 2 pinces coulissantes et serrage par vis à embout
- 2 tubes de longueur 1200 mm ajustable par recoupe

- Fixed panel is held in place by 2 sliding clips tightened by a plastic tipped screw
- 2 tubes 1200 mm length modified by cutting down to required size

1668.**.0

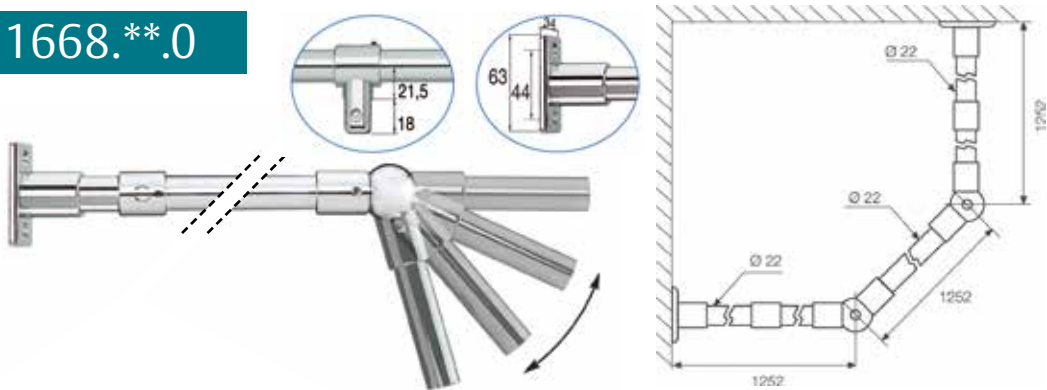

Références / References



Laiton poli PVD
Polished brass PVD



Chromé brillant
Bright chromium



Chromé mat
Matt chromium



Effet inox
Stainless steel effect

Barre raidisseur 3 volumes à angle réglable
Reinforcement bar 3 panels with adjustable angle

1668.05.0 1668.30.0 1668.31.0 1668.35.0

- Maintien des volumes fixes par 2 pinces coulissantes et serrage par vis à embout
- 3 tubes de longueur 1200 mm ajustable par recoupe

- Fixed panel is held in place by 2 sliding clips tightened by a plastic tipped screw
- 3 tubes 1200 mm length modified by cutting down to required size

Barres raidisseurs
pour volumes fixes
Reinforcement bars
for fixed panels

1669.**.0

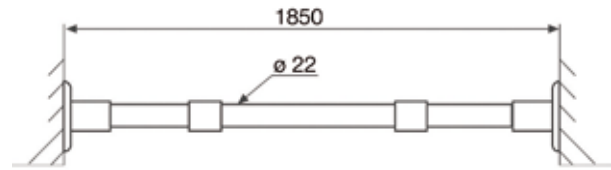
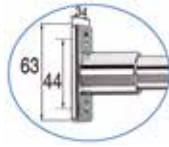

Références / References



Laiton poli PVD
Polished brass PVD



Chromé brillant
Bright chromium



Chromé mat
Matt chromium



Effet inox
Stainless steel effect

Barre raidisseur mur/mur
Reinforcement bar wall/wall

1669.05.0

1669.30.0

1669.31.0

1669.35.0

- Maintien des volumes fixes par 2 pinces coulissantes et serrage par vis à embout
- Tube de longueur 1800 mm ajustable par recoupe et 2400 mm en finition 05

- Fixed panel is held in place by 2 sliding clips tightened by a plastic tipped screw
- 1800 mm length tube modified by cutting down to required size and 2400 mm for finish 05

1669.**.2SQ

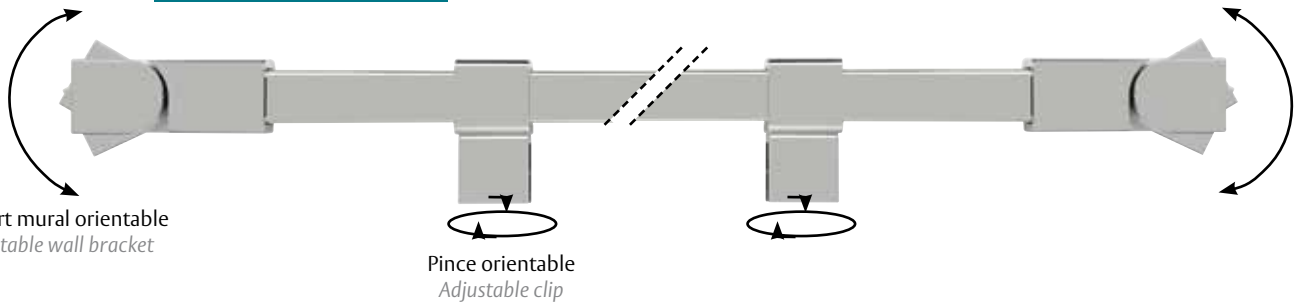

Support mural orientable
Adjustable wall bracket

Pince orientable
Adjustable clip

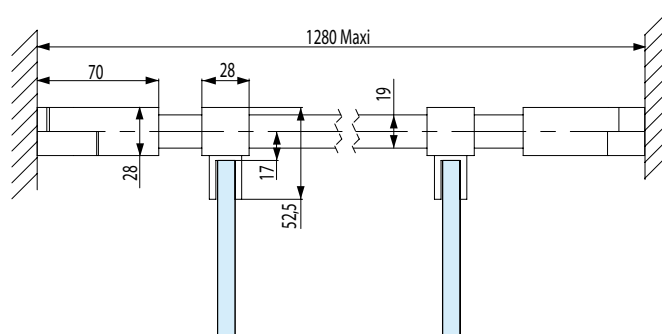

Références / References



Chromé brillant
Bright chromium



Chromé mat
Matt chromium

Barre raidisseur carrée mur/mur lg 1200 mm
Articulated square reinforcement bar for shower wall/wall 1200 mm length

1669.30.2SQ

1669.31.2SQ

- Possibilité de montage sous pente avec la platine de fixation orientable
- Maintien du volume fixe par pince orientable et serrage par vis à embout
- Tube de longueur 1200 mm ajustable par recoupe

- Possibility of assembling on an incline with an adjustable fixing plate
- Fixed panel is held in place by an adjustable clip tightened by a plastic tipped screw
- 1200 mm length tube modified by cutting down to required size

S110.**.0



Références / References



Chromé brillant
Bright chromium



Chromé mat
Matt chromium



Effet inox
Stainless steel effect

Taquet de fixation pour barre série 1651
Bracket for bar series 1651

S110.30.0

S110.31.0

S110.35.0

- Pour tube Ø 22 mm
- Maintien du volume fixe par pince orientable et serrage par vis à embout

- For Ø 22 mm tube
- Fixed panel is held in place by an adjustable clip tightened by a plastic tipped screw

S120.**.0



Laiton poli PVD
Polished brass PVD



Chromé brillant
Bright chromium



Chromé mat
Matt chromium



Effet inox
Stainless steel effect



Laqué blanc 9010
Lacquered white RAL 9010

Références / References

Pièce de fixation murale pour barres séries 1651/57/59/68/69
Wall fixing plate for bars series 1651/57/59/68/69

S120.05.0

S120.30.0

S120.31.0

S120.35.0

S120.51.0

- Pour tube Ø 22 mm
- For Ø 22 mm tube

S130.**.0



Références / References



Chromé brillant
Bright chromium



Chromé mat
Matt chromium



Effet inox
Stainless steel effect

Taquet avec coulisse pour barres séries 1659/68/69
Sliding bracket for bars series 1659/68/69

S130.30.0

S130.31.0

S130.35.0

- Pour tube Ø 22 mm
- Maintien du volume fixe par pince coulissante et serrage par vis à embout

- For Ø 22 mm tube
- Fixed panel is held in place by a sliding clip tightened by a plastic tipped screw

S140.**.0



Chromé brillant
Bright chromium



Chromé mat
Matt chromium



Effet inox
Stainless steel effect



Laqué blanc 9010
Lacquered white RAL 9010

Références / References



Embout avec taquet pour barre série 1657/1658
End cap for bars series 1657/58

S140.30.0

S140.31.0

S140.35.0

S140.51.0

- Pour tube Ø 22 mm
- Maintien du volume fixe par pince orientable et serrage par vis à embout

- For Ø 22 mm tube
- Fixed panel is held in place by an adjustable clip tightened by a plastic tipped screw

Accessoires pour
barre raidisseur
Ø 22 mm
Accessories for
reinforcement bar
Ø 22 mm

Accessoires pour
barre raidisseur
ø 22 mm
Accessories for
reinforcement bar
ø 22 mm

S150.**.0



Références / References

Coude réglable pour TUBE Ø 22 mm
Adjustable bend for Ø 22 mm tube



Chromé brillant
Bright chromium

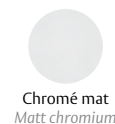

Chromé mat
Matt chromium

S150.30.0

S150.31.0

S151.**.0



Références / References

Pièce de raccord pour tube ø 22 mm
Connector for ø 22 mm tube



Chromé brillant
Bright chromium

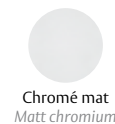

Chromé mat
Matt chromium

S151.30.0

S151.31.0

• Maintien du volume fixe par pince orientable et serrage par vis à embout • Fixed panel is held in place by an adjustable clip tightened by a plastic tipped screw

S152.**.0



Références / References

Raccordement en T
T-Connector for reinforcement bars



Chromé brillant
Bright chromium



Chromé mat
Matt chromium



Effet inox
Stainless steel effect

S152.30.0

S152.31.0

S152.35.0

• Pour tube Ø 22 mm • For Ø 22 mm tube

S154.**.0



Références / References

Pièce de liaison pour 2 tubes
Connector for 2 tubes



Laiton poli PVD
Polished brass PVD



Chromé brillant
Bright chromium

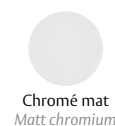

Chromé mat
Matt chromium

S154.05.0

S154.30.0

S154.31.0

• Pour tube Ø 22 mm • For Ø 22 mm tube

Tubes



Références / References

T120.**.0

Tube Ø 22 mm lg 1200 mm
Tube Ø 22 mm 1200 mm length



Chromé brillant
Bright chromium



Chromé mat
Matt chromium



Effet inox
Stainless steel effect

T120.30.0

T120.31.0

T120.35.0

T180.**.0

Tube Ø 22 mm lg 1800 mm
Tube Ø 22 mm 1800 mm length

T180.30.0

T180.31.0

T180.35.0

1660.**.0

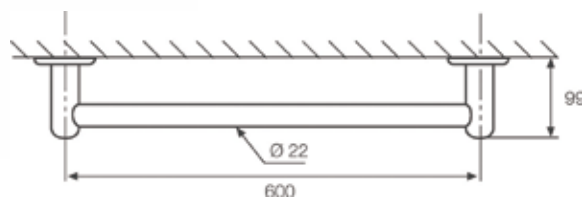

Chromé brillant
Bright chromium



Chromé mat
Matt chromium

Références / References

Porte serviette simple fixation murale
Single towel rail for wall

1660.30.0

1660.31.0

- Fixation sur le mur par platine (visserie fournie)
- Longueur standard du tube 600 mm
- Tube de longueur 600 mm recoupable pour mise à longueur

- Fixed on the wall by plate (screws provided)
- Standard length of tube 600 mm
- Tube 600 mm modified by cutting down lengthwise

Porte serviettes et
porte tablettes
Towel rail and
shelf supports



1661.**.0

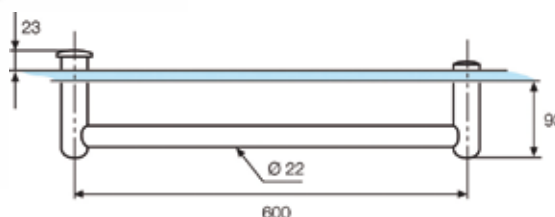

Chromé brillant
Bright chromium



Chromé mat
Matt chromium



Effet inox
Stainless steel effect

Références / References



Porte serviette simple fixation verre
Single towel rail for glass

1661.30.0

1661.31.0

1661.35.0

- Bouton de manoeuvre intérieur (livré avec 2^{ème} écrou de fixation pour utilisation sans bouton intérieur)
- Montage sur trous Ø 16 mm
- Longueur standard du tube 600 mm, entr'axe des trous à 600 mm
- Tube de longueur 600 mm recoupable pour mise à longueur, l'entr'axe des trous de fixation est égal à la longueur du tube

- Knob for manoeuvring on inside (supplied with a second fixing nut to use instead of inside knob)
- To be assembled on 16 mm Ø hole
- Standard length of tube 600 mm, central distance between hole cut-outs 600 mm
- Tube 600 mm modified by cutting down lengthwise, the central distance is equal to the length of the tube

LES + PRODUITS
The + product

Double fonction :
tirage et support ser-
viette

Esthétique
compatible avec
les barres raidisseurs

Double fonction :
Pulling handle and
towel rail

Attractive match
with reinforcement
bars

1662.**.0

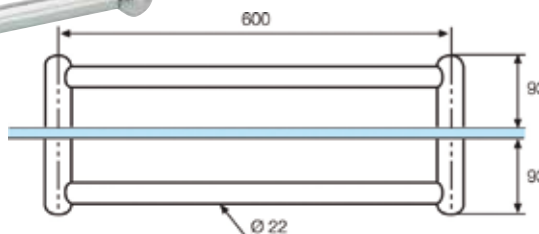

Chromé brillant
Bright chromium



Chromé mat
Matt chromium

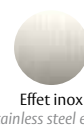

Effet inox
Stainless steel effect



Porte serviette double fixation verre
Double towel rail for glass

Références / References

1662.30.0

1662.31.0

1662.35.0

- Barre de manoeuvre intérieure
- Montage sur trous Ø 16 mm
- Longueur standard du tube 600 mm, entr'axe des trous à 600 mm
- Tube de longueur 600 mm recoupable pour mise à longueur, l'entr'axe des trous de fixation est égal à la longueur du tube

- Bar for manoeuvring on inside
- To be assembled on 16 mm Ø hole
- Standard length of tube 600 mm, central distance between hole cut-outs 600 mm
- Tube 600 mm modified by cutting down lengthwise, the central distance is equal to the length of the tube

Porte serviettes et
porte tablettes
Towel rail and
shelf supports

1664.**.0

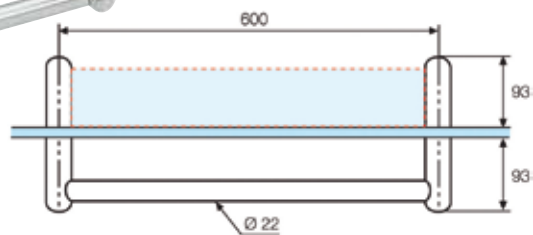

Références / References



Porte serviette avec porte tablette intérieur
Towel rail with interior shelf



Chromé brillant
Bright chromium



Chromé mat
Matt chromium

1664.30.0

1664.31.0

- Porte serviette extérieur
- Porte tablette verre intérieur
- Montage sur trous Ø 16 mm
- Longueur standard du tube porte serviette 600 mm, entr'axe des trous à 600 mm
- Tube recoupable pour mise à longueur, l'entr'axe des trous est égal à la longueur du tube
- Pour tablette en verre épaisseur 6 mm largeur 80 mm (non fournie)
- La longueur de la tablette est égale à l'entr'axe de fixation des supports -16 mm

- Exterior towel rail
- Interior glass shelf support
- Assembling on holes dia 16 mm
- Standard length of towel rail tube 600 mm, central distances between hole cut-outs 600 mm
- Tube modified by cutting down lengthwise, the central distance is equal to the length of tube
- For 6 mm glass shelf 80 mm wide (not supplied)
- The length of the shelf is equal to the support's fixing point -16 mm

Attention : Le verre de la tablette n'est pas fourni

Attention : The glass shelf is not supplied

1665.**.0

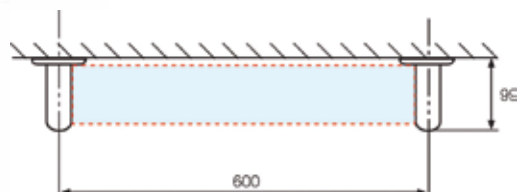

Références / References

Porte tablette fixation murale
Shelf support for assembling on wall



Chromé brillant
Bright chromium



Chromé mat
Matt chromium

1665.30.0

1665.31.0

- Fixation sur le mur par platine (visserie fournie)
- Pour tablette en verre épaisseur 6 mm largeur 80 mm
- La longueur de la tablette est égale à l'entr'axe de fixation des supports -16 mm

- Fixed onto the wall by a plate (screws supplied)
- For 6 mm glass shelf 80 mm wide
- The length of the shelf is equal to the central distance of the support's fixing point -16 mm

Attention : Le verre de la tablette n'est pas fourni

Attention : The glass shelf is not supplied

Porte serviettes et
porte tablettes
*Towel rail and
shelf supports*



Joint pour portes
et pare douches
*Sealing strips for
shower doors and
screens*

1801.66.*

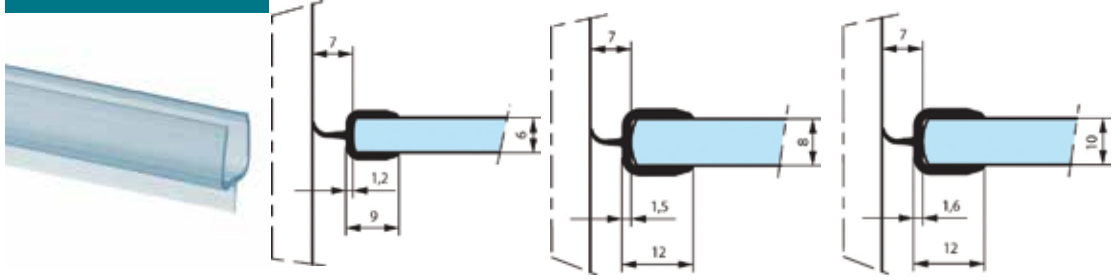

Références / References



Joint translucide à lèvre centrale
Translucent sealing strip with central lip

1801.66.2

1801.66.3

1801.66.4

- Longueur 2200 mm
- Unité de vente : 1 joint, conditionné par 5

- Length 2200 mm
- Sold in units, packed by 5

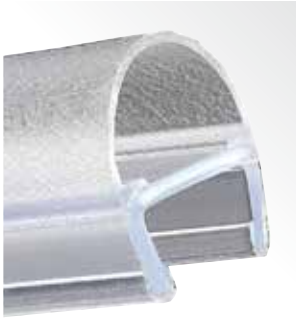

LES + PRODUITS
The + product

Améliore
l'étanchéité
Gamme complète

*Improved
waterproofing
Complete range*

1806.66.*



1806.66.0

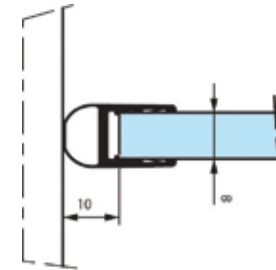
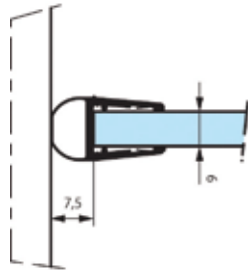

1806.66.4

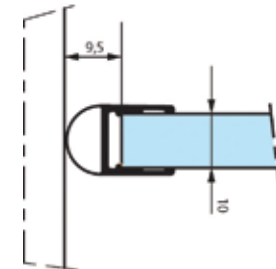
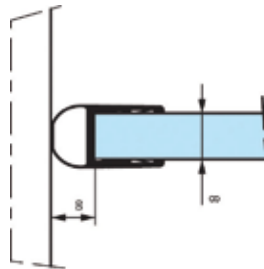

Références / References



Joint translucide bourrelet
Translucent sealing strip with compressor

1806.66.0

1806.66.4

- Longueur 2200 mm
- Unité de vente : 1 joint, conditionné par 5

- Length 2200 mm
- Sold in units, packed by 5

1800.66.*

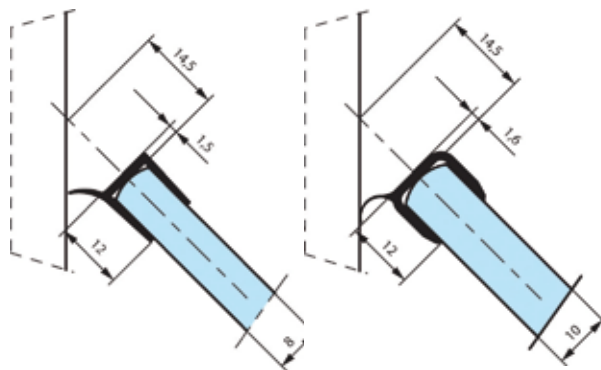

Joints pour portes
et pare douches
Sealing strips for
shower doors and
screens

Références / References

Joint translucide à lèvres déportée
Translucent sealing strip with off-set lip



1800.66.3



1800.66.4

- Longueur 2200 mm
- Unité de vente : 1 joint, conditionné par 1

- Length 2200 mm
- Sold in units, packed by 1

1806.66.* MR



1806.66.3MR



1806.66.4MR

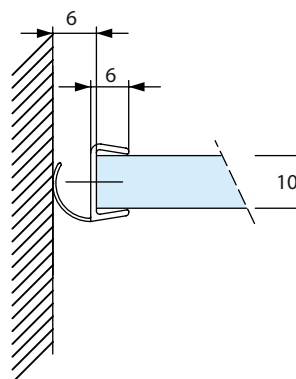
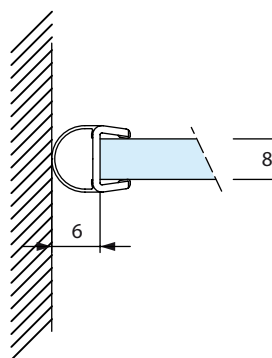

Références / References

Joint translucide bourrelet masse réduite
Translucent super slim seal with lip compressor



1806.66.3MR



1806.66.4MR

- Longueur 2200 mm
- Unité de vente : 1 joint, conditionné par 1

- Length 2200 mm
- Sold in units, packed by 1

Jointes pour portes
et pare douches
*Sealing strips for
shower doors and
screens*

1802.66.*

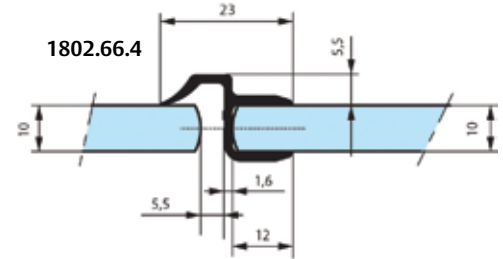
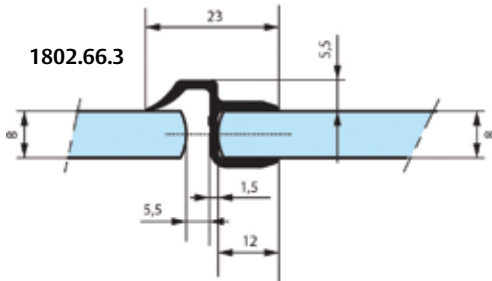
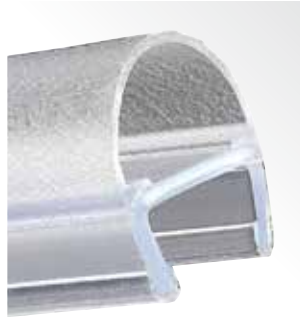
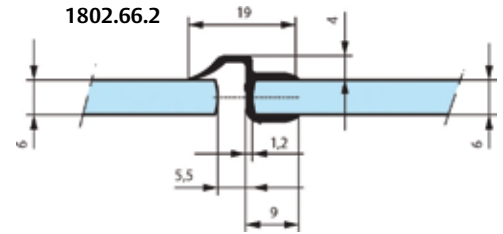

Références / References

Jointe translucide à lèvres déportées
Translucent sealing strip with off-set lip



1802.66.2

1802.66.3

1802.66.4

- Préconisé pour une utilisation entre un volume fixe et un volume mobile à 180°
- Longueur 2200 mm
- Unité de vente : 1 joint, conditionné par 5

- Recommended to prevent water escaping between a fixed and moving panel at 180°
- Length 2200 mm
- Sold in units, packed by 5

1803.66.*

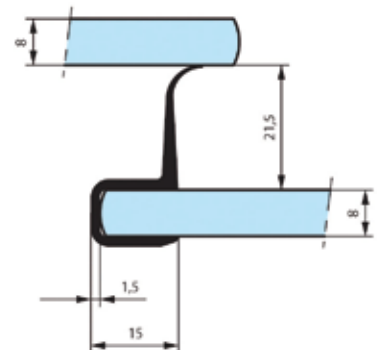
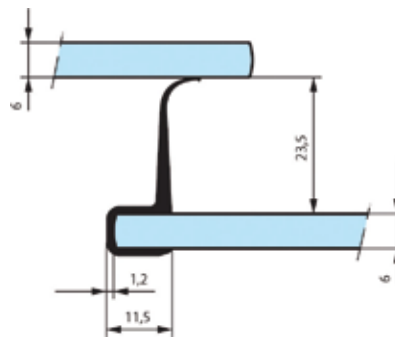

Références / References

Jointe translucide à lèvres latérales
Translucent sealing strip with lateral lip

1803.66.2

1803.66.3

- Pour charnières à recouvrement 3163
- Longueur 2200 mm
- Unité de vente : 1 joint, conditionné par 1

- For overlapping shower hinges 3163
- Length 2200 mm
- Sold in units, packed by 1

1803.66.3MR

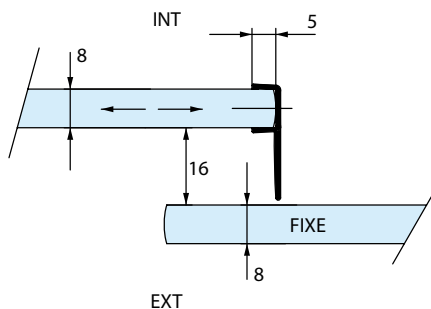

Références / References

Joint translucide à lèvres latérales masse réduite
Translucent super slim seal with lateral lip

1803.66.3MR

- Longueur 2010 mm
- Unité de vente : 1 joint, conditionné par 1

- Length 2010 mm
- Sold in units, packed by 1

1804.66.3

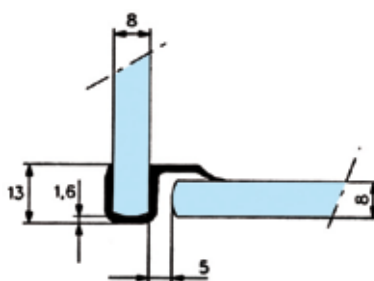

Références / References

Joint translucide à lèvres avec butée
Translucent sealing strip with lip and stop

1804.66.3

- Préconisé pour une utilisation entre un volume fixe et un volume mobile à 90°
- Longueur 2200 mm
- Unité de vente : 1 joint, conditionné par 1

- Recommended to prevent water escaping between a fixed and moving panel at 90°
- Length 2200 mm
- Sold in units, packed by 1

Jointes pour portes
et pare-douches
*Sealing strips for
shower doors and
screens*

Joint pour portes
et pare douches
Sealing strips for
shower doors and
screens

1805.66.*

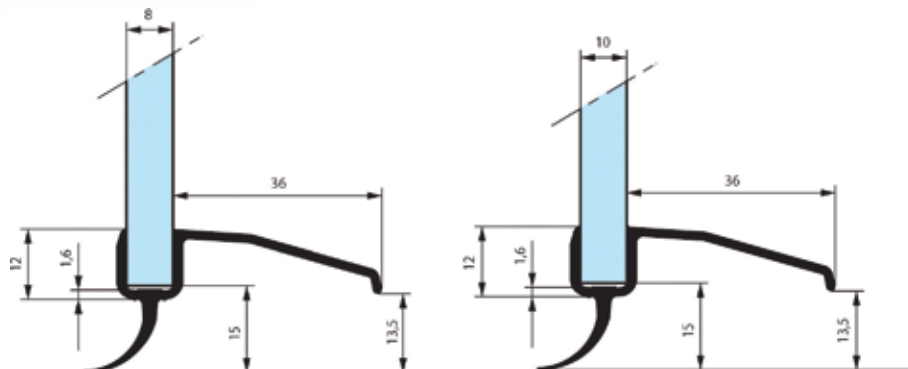
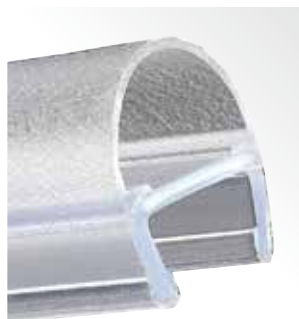

Références / References

Joint translucide bas de porte
Translucent sealing strip for bottom of door

1805.66.3

1805.66.4

- Longueur 2200 mm
- Unité de vente : 1 joint, conditionné par 1

- Length 2200 mm
- Sold in units, packed by 1

1809.66.0

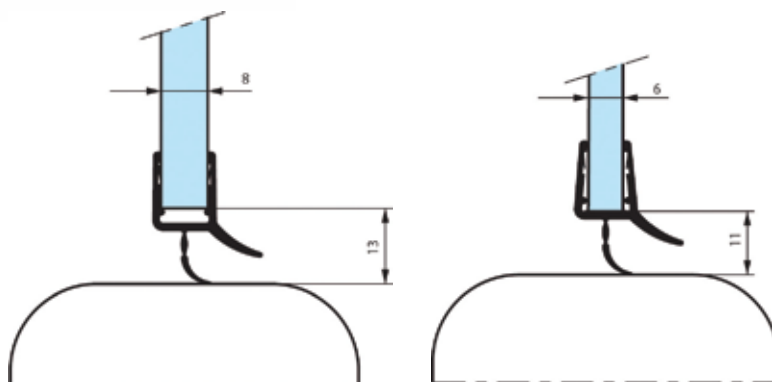

Références / References

Joint translucide bas de porte
Translucent sealing strip for bottom of door

1809.66.0

- Longueur 2000 mm
- Unité de vente : 1 joint, conditionné par 5

- Length 2000 mm
- Sold in units, packed by 5

Jointes pour portes
et pare douches
*Sealing strips for
shower doors and
screens*



Jointes pour portes
et pare douches
*Sealing strips for
shower doors and
screens*

2900.66.*



LES + PRODUITS

The + product

Double fonction :
blocage et optimisation
de l'étanchéité

*Double function :
blocking and
improved waterproofing*

2900.66.3

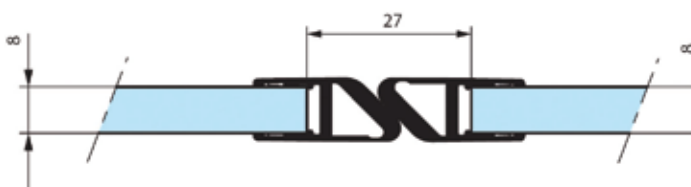
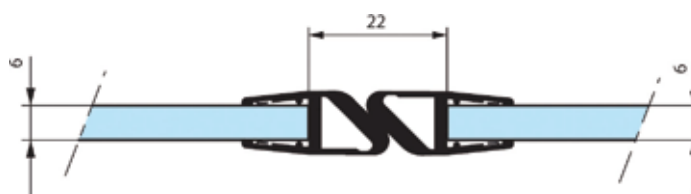

2900.66.4

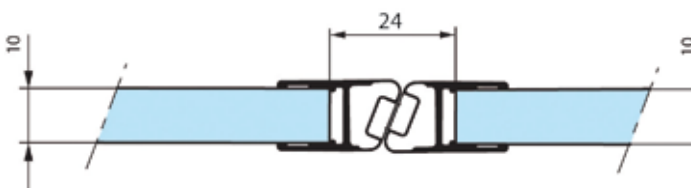
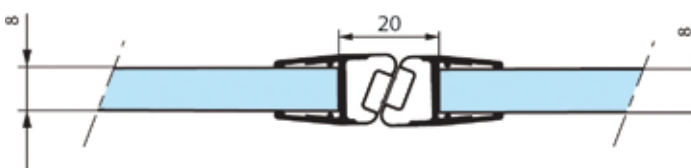

Références / References



Jointes magnétiques translucides
Magnetic translucent sealing strip

2900.66.3

2900.66.4

- Préconisé pour assurer la fermeture entre 2 volumes à 180°
- Longueur 2200 mm
- Unité de vente : 1 joint, conditionné par 1

- Recommended for 2 panels at 180°
- Length 2200 mm
- Sold in units, packed by 1

2901.66.*



Joints pour portes
 et pare douches
*Sealing strips for
 shower doors and
 screens*

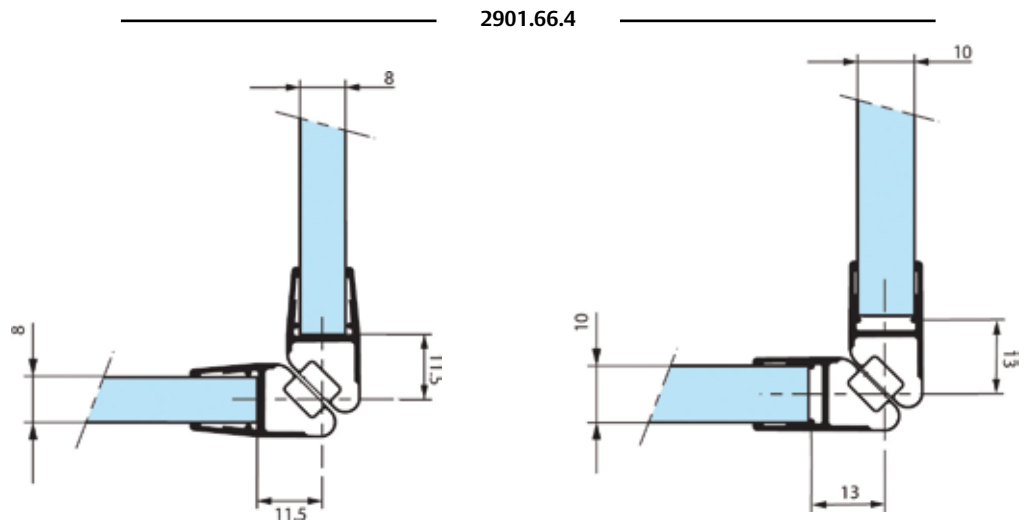
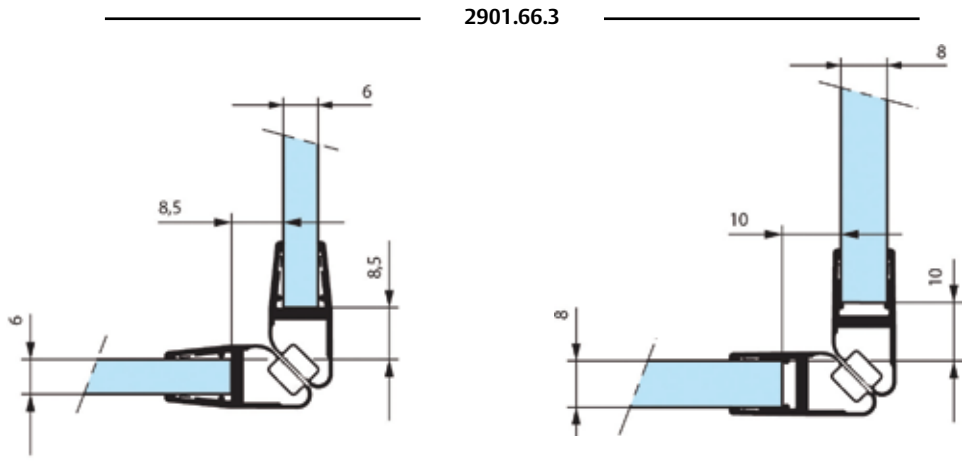

Références / References

Joints magnétiques translucides
Magnetic translucent sealing strip

- Préconisé pour assurer la fermeture entre 2 volumes à 90°
- Longueur 2200 mm
- Unité de vente : 1 joint, conditionné par 1

- Recommended for 2 panels at 90°
- Length 2200 mm
- Sold in units, packed by 1



2901.66.3



2901.66.4

Jointes pour portes
et pare douches
Sealing strips for
shower doors and
screens

2902.66.*



2902.66.3

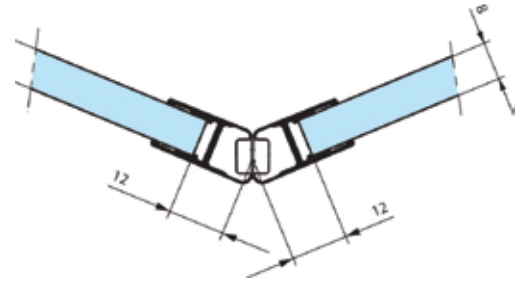
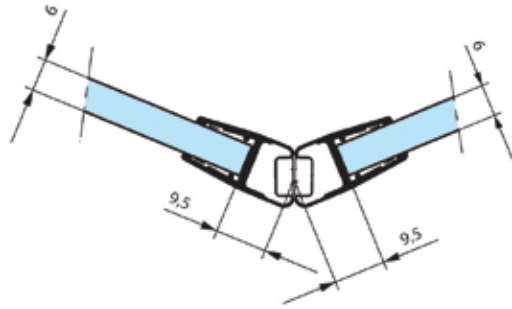

2902.66.4

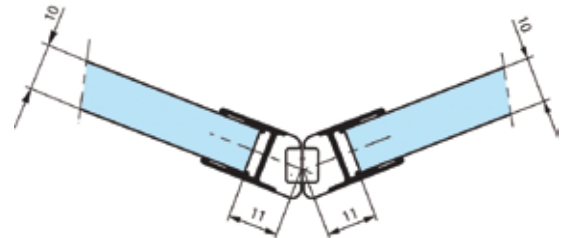
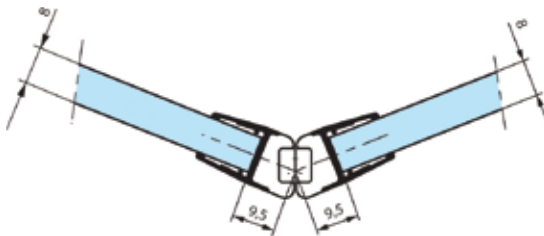

Références / References



Jointes magnétiques translucides
Magnetic translucent sealing strip

2902.66.3

2902.66.4

- Préconisé pour assurer la fermeture entre 2 volumes à 135°
- Longueur 2200 mm
- Unité de vente : 1 joint, conditionné par 1

- Recommended for 2 panels at 135°
- Length 2200 mm
- Sold in units, packed by 1

2903.66.3

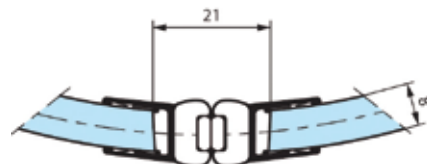
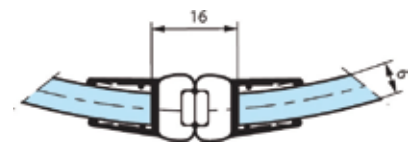

Références / References



Jointes magnétiques translucides
Magnetic translucent sealing strip

2903.66.3

- Préconisé pour assurer la fermeture entre 2 volumes bombés
- Longueur 2200 mm
- Unité de vente : 1 joint, conditionné par 1

- Recommended for 2 curved glass panels
- Length 2200 mm
- Sold in units, packed by 1



Film antibuée
pour miroir
*Demisting film
for mirror*



LES + PRODUITS
The + product

Installation facile

Easy installation

5870.99.*

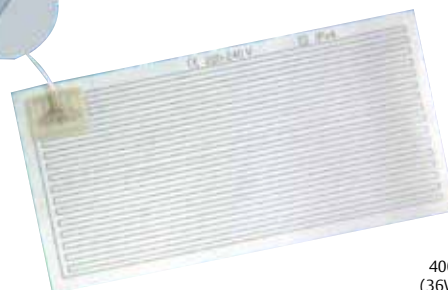

Références / References

Film antibuée pour miroir
Demisting film for mirrors

400 x 500 mm
(36W 220-240V)

550 x 800 mm
(78W 220-240V)

5870.99.0

5870.99.1

- Evite la formation de buée sur les miroirs due à la condensation
- Pose facile par adhésif acrylique, sans dommage pour le miroir
- Assure la fonction de film anti-éclat en cas de bris de miroir
- Désembuage efficace, temps de chauffe inférieur à 1 minute
- Aucun risque de brûlure, système autorégulant à 38°
- Conforme aux normes européennes, homologation EN 60 33561 (12.96)
- Certificat de conformité du laboratoire LCIE N° 1107
- Unité de vente : 1 film antibuée

- To help prevent the build up of mist on mirrors due to condensation
- Easy fitting with acrylic adhesive, without damage to the mirror
- Ensures the operation of anti-shatter film in the event of the mirror breaking
- Effective demisting, heating time in under 1 minute
- No burn risk, self adjusting heating system set at 38°
- Complies with European Standards, approved under EN 60 33561 (12.96)
- Certificate of laboratory compliance LCIE N° 1107
- Sold per unit

Serrures de vitrine
pour porte
à battant
*Showcase lock
for swing doors*

1470.**.0

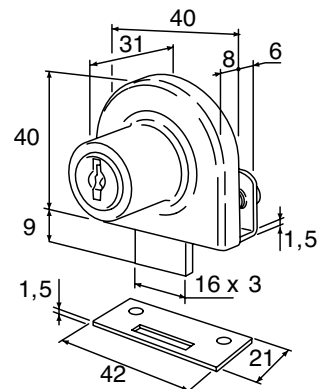

Références / References



Chromé brillant
Bright chromium

Serrure de vitrine sans encoche
Showcase lock without notch

1470.30.0

LES + PRODUITS

The + product

Sans encoche

No notch

- Retrait de la clé en position ouverte ou fermée
- Possibilité de serrures sur même numéro
- Combinaison de clé possible avec les serrures de vitrines 1471
- Serrage par 2 vis à embout
- Livrée avec 2 clés, une gâche plate

- The key can be removed in locked and unlocked position
- Locks may be supplied on same number
- May be combined with showcase locks series 1471
- Tightened with 2 tipped screws
- Supplied with 2 keys and 1 flat keep

1479.**.0

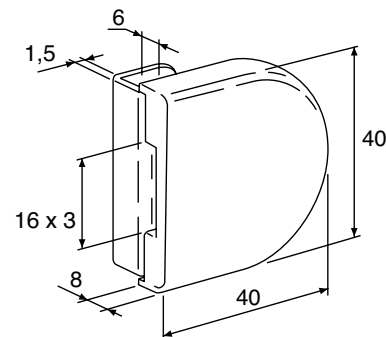

Références / References



Chromé brillant
Bright chromium

Boîtier gâche sans encoche pour serrure de vitrine 1470
Patch keep without notch for 1470 lock

1479.30.0

- Serrage par 2 vis à embout

- Tightened with 2 tipped screws

1471.**.0

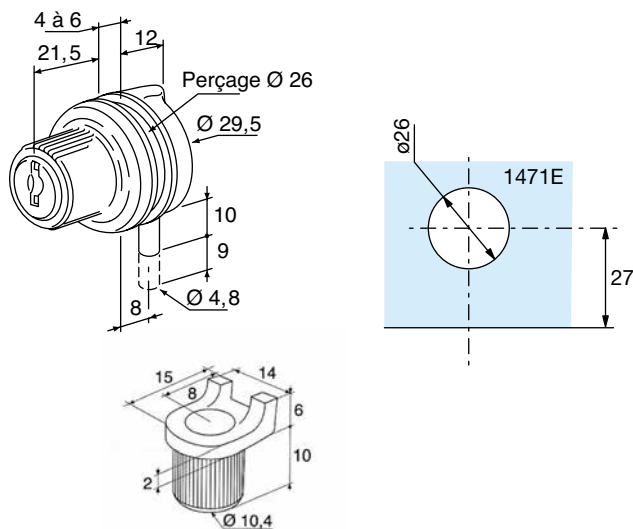

Serrures de vitrine
pour porte
à battant
*Showcase lock
for swing doors*

Références / References



Chromé brillant
Bright chromium

Serrure pour porte battante
Lock for swing door

1471.30.0

- Montage sur encoche 1471E
- Retrait de la clé en position ouverte ou fermée
- Possibilité de serrures sur même numéro
- Combinaison de clé possible avec les serrures de vitrines 1470
- Livrée avec 2 clés, une butée gâche

- For notch 1471E
- The key can be removed in locked and unlocked position
- Locks may be supplied on same number
- May be combined with showcase locks series 1470
- Supplied with 2 keys and 1 keep

1456.**.0

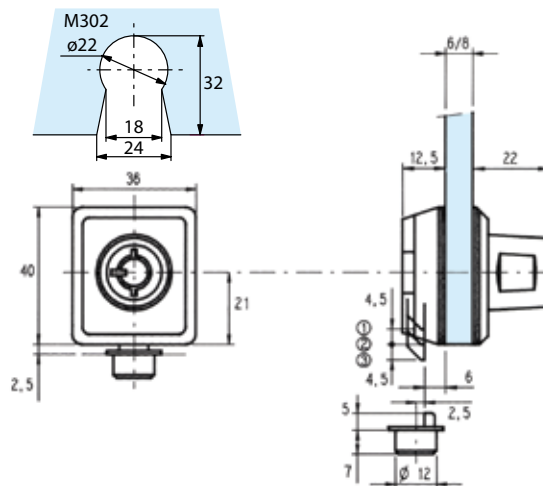
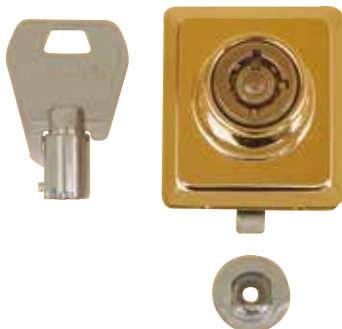

Références / References



Chromé brillant
Bright chromium



Chromé mat
Matt chromium



Doré
Gold plated

Serrure de vitrine
Showcase lock

1456.30.0

1456.31.0

1456.40.0

- Montage sur encoche M302 ou trou Ø 22 mm
- 3 positions de clé
 - 1 – Pêne complètement rétracté
 - 2 – Pêne auto-rétractable en position intermédiaire
 - 3 – Pêne bloqué en position de fermeture
- Cylindre à pistons radiaux, 10 000 combinaisons différentes
- Possibilité de serrures sur même numéro
- Possibilité de clé sur même numéro avec la serrure 1457
- Retrait de la clé à chaque position
- Livrée avec 2 clés et 1 gâche cylindrique à butée

- For notch M302 or 22 mm Ø hole
- 3 key positions
 - 1 – Completely retracted bolt
 - 2 – Self retracting bolt in intermediary position
 - 3 – Bolt blocked in locked position
- 10 000 combinations radial pin cylinder
- Locks may be supplied on same key number
- Key may be supplied with number corresponding to lock 1457
- Key can be withdrawn at all positions
- Supplied with 2 keys and a cylindrical keep stop

Serrures de vitrine
pour porte
à battant
*Showcase lock
for swing doors*

1450.**.0

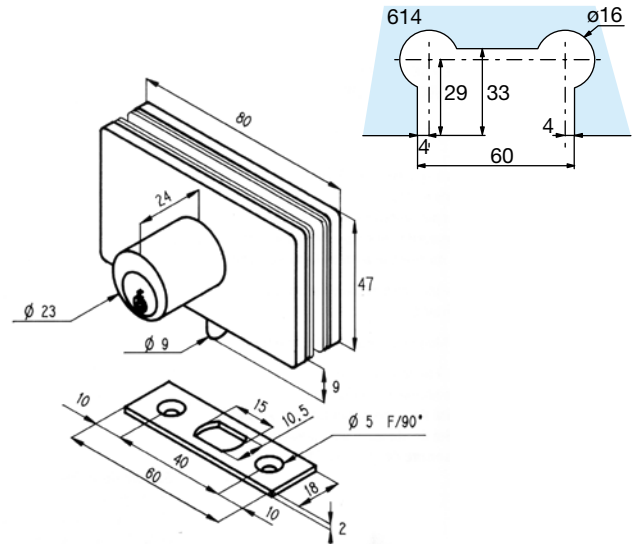

Références / References



Chromé brillant
Bright chromium



Chromé mat
Matt chromium



Doré
Gold plated

Serrure de vitrine
Showcase lock

1450.30.0

1450.31.0

1450.40.0

- Serrure équipée d'un pêne demi-tour biseauté
- Montage sur encoche 614
- Clé prisonnière
- Fermeture de la porte par simple poussée, sans utilisation de la clé, pêne auto rétractable (Pas de blocage de pêne).
- Possibilité d'installation sur organigramme et même numéro
- Livrée 3 clés, 1 gâche plate

- Lock fitted with beveled spring bolt
- For notch 614
- Lock with captive key
- Door locks when pushed shut without use of key, self retracting bolt
- May be fitted in accordance with key chart and on same number
- Supplied with 3 keys and a flat keep

1452.**.0

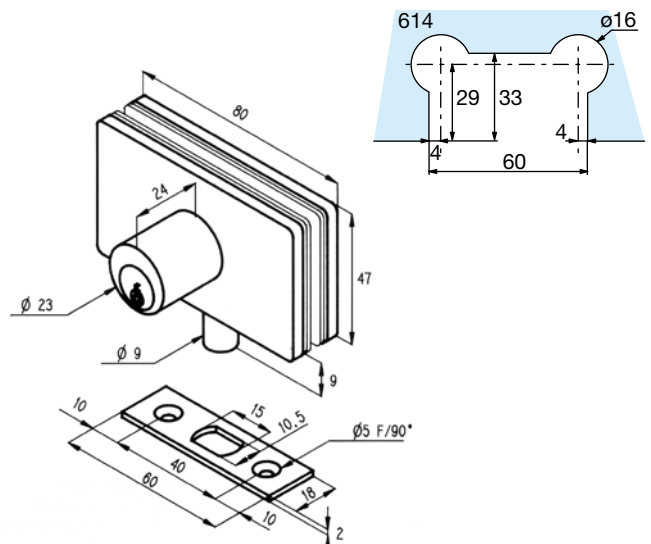

Références / References



Chromé brillant
Bright chromium



Chromé mat
Matt chromium



Doré
Gold plated

Serrure de vitrine
Showcase lock

1452.30.0

1452.31.0

1452.40.0

- Serrure équipée d'un pêne dormant rond
- Montage sur encoche 614
- Clé prisonnière
- Fermeture de la porte avec la clé
- Possibilité d'installation sur organigramme et même numéro
- Livrée avec 3 clés, 1 gâche plate

- Lock with round spring bolt
- For notch 614
- Lock with captive key
- Door locks with key
- May be fitted in accordance with key chart and on same number
- Supplied with 3 keys and a flat keep

Serrures de vitrine
pour porte
à battant
*Showcase lock
for swing doors*



Serrures de vitrine
à came batteuse
Cam showcase
locks

1455.**.0

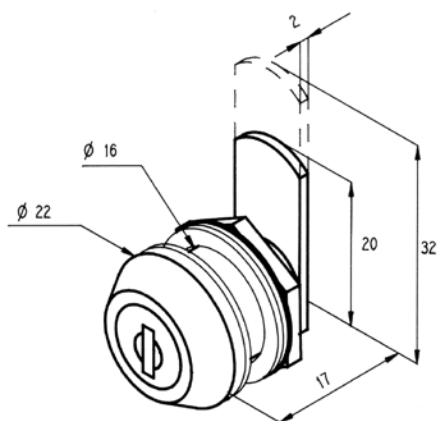

Chromé brillant
Bright chromium

Références / References



Serrure de vitrine à came batteuse
Cam showcase locks

1455.30.0



- Montage sur trou Ø 17 mm
- Ouverture et fermeture à la clé
- Retrait de la clé en position ouverte ou fermée
- Cylindre à paillettes 200 combinaisons différentes
- Possibilité de serrures sur même numéro
- Combinaison de clé possible avec la serrure série 1454
- Livrée avec 2 clés et 2 cames lg 20 et 32 mm (L'axe du cylindre).
- Position de l'axe du trou par rapport au bord du verre =
Longueur de la came – jeu entre la bas de la porte et
le socle – longueur de pénétration de la came dans le socle

- Fixes onto 17 mm Ø hole
- Locks and unlocks with key
- Key removed in locked or unlocked position
- Equipped with 200 combination pin-tumbler cylinder
- Locks may be supplied on same number
- May be combined with showcase lock series 1454
- Supplied with 2 keys and a 20 mm and 32 mm long cam (cylinder axis)
- Position of hole's axis from the edge of the glass =
Cam length – space between the end of the door and the showcase
frame – length of cam's entry into the frame

1457.**.0

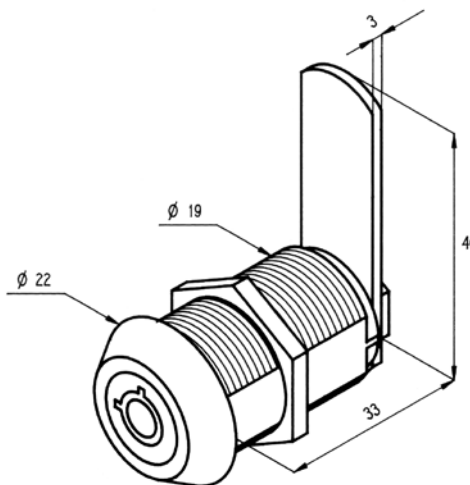

Chromé brillant
Bright chromium

Références / References

Serrure pour tiroir à came batteuse
Cam showcase locks

1457.30.0

- Pour tiroir épaisseur 22 mm maximum
- Montage sur trou Ø 19 mm
- Ouverture et fermeture à la clé
- Retrait de la clé en position ouverte ou fermée
- Cylindre à pistons radiaux, 10 000 combinaisons différentes
- Possibilité de serrures sur même numéro
- Combinaison de clé possible avec les serrures série 1456
- Livrée avec 2 clés et 1 came lg 40 mm (L'axe du cylindre).

- For drawer 22 mm thick maximum
- Fixes onto 19 mm Ø hole
- Locks and unlocks with key
- Key may be removed in locked and or unlocked position
- 10 000 combination radial piston cylinder
- Locks may be supplied on same number
- May be combined with showcase lock series 1456
- Supplied with 2 keys and a 40 mm long cam (from cylinder axis)

1454.**.0

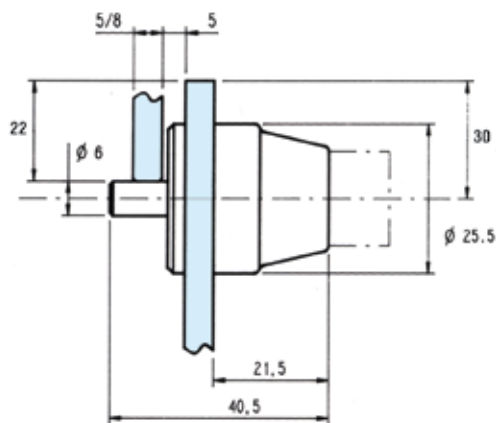

Chromé brillant
Bright chromium

Références / References



Serrure de vitrine à poussoir
Push button lock

1454.30.0

- Montage sur trou Ø 22 mm à 30 mm minimum du bord du verre
- Recouvrement des verres de 22 mm
- Jeu entre les verres 5 mm
- Ouverture avec la clé par décondamnation du bouton poussoir
- Fermeture par simple pression sur le bouton poussoir
- Possibilité de serrures sur même numéro
- Combinaison de clé possible avec la serrure série 1455
- Livrée avec 2 clés

- Fixes onto 22 mm Ø hole to 30 mm minimum from edge of glass
- Overlap on glass 22 mm
- 5 mm play between panels
- Unlocks with key in push button keyhole
- Locks by simple pressure on push button
- Locks may be supplied on same number
- May be combined with showcase lock series 1455
- Supplied with 2 keys

1459.**.0

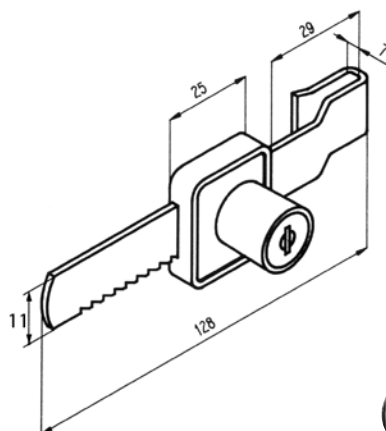

Chromé brillant
Bright chromium

Références / References



Serrure à crémaillère
Ratchet

1459.30.0

- Pour verre épaisseur 4 à 8 mm maxi
- Montage sans encoche
- Recouvrement des glaces de 30 mm minimum
- Jeu entre glaces à partir de 3,5 mm
- Serrure amovible à crémaillère pour 2 portes coulissantes
- Fermeture par coulissement du bloc serrure sur la crémaillère
- Crémaillère équipée d'une vis de serrage
- Ouverture par clé
- Barillet à paillettes 100 combinaisons différentes
- Possibilité de serrures sur même numéro
- Livrée avec 2 clés
- Unité de vente : 1 serrure

- For 4 to 8 mm thick glass
- Fitted without notch
- 30 mm minimum overlap on panels
- Play between panels from 3,5 mm
- Removable lock for two sliding doors
- Locks by sliding lock body on the ratchet
- Ratchet fitted with a tightening screw
- Unlock with key
- 100 combination pin tumbler cylinder
- Locks may be supplied on same number
- Supplied with two keys
- Sold per unit

Serrures de vitrine pour porte coulissante
Showcase locks for sliding doors

Serrures de sécurité pour porte ou tiroir en bois
Security showcase lock for wooden door or drawer

1460.**.0

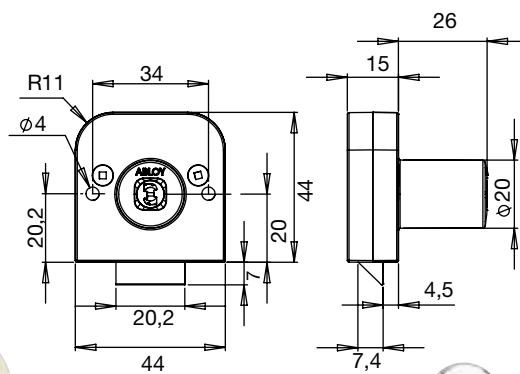

Chromé brillant
Bright chromium

Références / References



Serrure de sécurité à pêne biseauté
Security lock with spring bolt beveled

1460.30.0

- Pour bois ou mélaminé de 20 mm d'épaisseur maxi
- Montage sur trou Ø 23 mm
- Fonction clé prisonnière paramétrable
- Clé réversible
- Cylindre de sécurité à disques rotatifs
- Possibilité de serrures : - sur même numéro
- sur organigramme
- nombre de clés à définir à la commande
- Combinaison de clé avec les serrures
1461, 1462, 1463, 1464, 1465, 1466, 1467, 1468
- Livrée avec 1 gâche, 1 rosace, 2 clés en version variée

- For wood or particle board, max 20 mm thick
- Fits onto Ø 23 mm hole
- Function with or without captive key
- Reversible key
- Security cylinder with rotary disc
- Locks may be supplied : - on same number
- on key chart
- number of keys to be indicated when ordering
- May be combined with locks series
1461, 1462, 1463, 1464, 1465, 1466, 1467, 1468
- Supplied with 1 flat keep, 1 rosace, 2 keys

LES + PRODUITS
The + product

Cylindre de sécurité
Gamme complète, pour vitrine, tiroir et meuble

Security cylinder
Complete range for showcase, drawer and furniture

1462.**.0

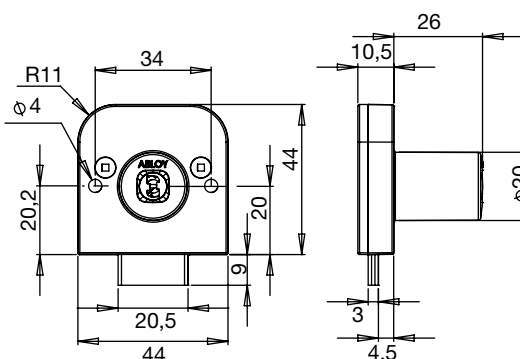

Chromé brillant
Bright chromium

Références / References



Serrure de sécurité à pêne dormant
Security lock with dead bolt

1462.30.0

- Pour bois ou mélaminé de 25 mm d'épaisseur maxi
- Montage sur trou Ø 23 mm
- Fonction clé prisonnière paramétrable
- Clé réversible
- Cylindre de sécurité à disques rotatifs
- Possibilité de serrures : - sur même numéro
- sur organigramme
- nombre de clés à définir à la commande
- Combinaison de clé avec les serrures
1460, 1461, 1463, 1464, 1465, 1466, 1467, 1468
- Livrée avec 1 gâche, 1 rosace, 2 clés en version variée

- For wood or particle board, max 20 mm thick
- Fits onto Ø 23 mm hole
- Function with or without captive key
- Reversible key
- Security cylinder with rotary disc
- Locks may be supplied : - on same number
- on key chart
- number of keys to be indicated when ordering
- May be combined with locks series
1461, 1462, 1463, 1464, 1465, 1466, 1467, 1468
- Supplied with 1 flat keep, 1 rosace, 2 keys

1462.**.0C

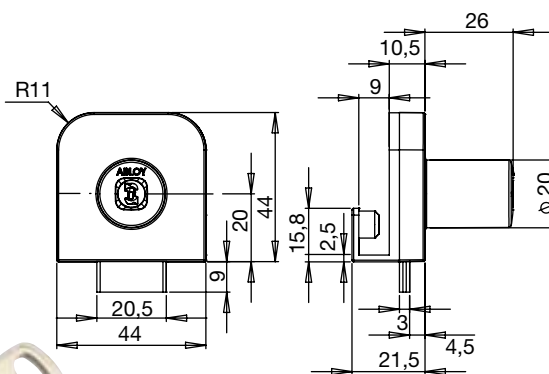

Chromé brillant
Bright chromium

Références / References



Serrure de sécurité à pêne dormant
Security lock with dead bolt

1462.30.0C

- Montage sans encoche
- Fonction clé prisonnière paramétrable
- Clé réversible
- Cylindre de sécurité à disques rotatifs
- Possibilité de serrures : - sur même numéro
- sur organigramme
- nombre de clés à définir à la commande
- Combinaison de clé avec les serrures
1460, 1461, 1463, 1464, 1465, 1466, 1467, 1468
- Livrée avec 1 gâche, 2 clés en version variée

- No notch required
- Function with or without captive key
- Reversible key
- Security cylinder with rotary disc
- Locks may be supplied : - on same number
- on key chart
- number of keys to be indicated
when ordering
- May be combined with locks series
1460, 1461, 1463, 1464, 1465, 1466, 1467, 1468
- Supplied with 1 flat keep, 2 keys

Serrures
de sécurité pour
porte en verre
Security showcase
lock for glass door

Serrures
de sécurité pour
porte coulissante
Security showcase
lock for sliding door

1464.**.0

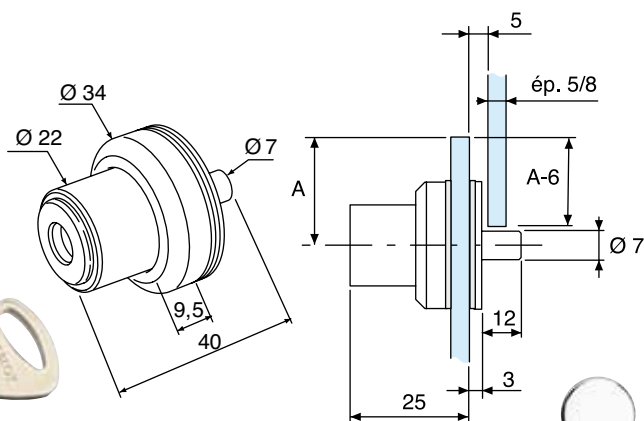

Références / References



Chromé brillant
Bright chromium

Serrure de sécurité à poussoir
Security push button lock

1464.30.0

- Montage sur trou Ø 30 mm (axe du trou à 25 mm du bord du verre)
- Ouverture à la clé par décondamnation du bouton poussoir
- Clé réversible
- Fermeture par simple pression sur le bouton poussoir
- Recouvrement des portes de A - 6 mm
- Jeu entre les portes 5 mm
- A = Position du trou par rapport au bord du verre
- Cylindre de sécurité à disques rotatifs
- Possibilité de serrures : - sur même numéro
- sur organigramme
- Nombre de clés à définir à la commande
- Combinaison de clé avec les serrures
1460, 1461, 1462, 1463, 1465, 1466, 1467, 1468
- Livrée avec 2 clés en version variée

- Fits onto Ø 30 mm hole (hole axis at 25 mm from the edge)
- Unlocking with the key
- Reversible key
- Locking with the push button
- Doors overlap A - 6 mm
- Space between the doors 5 mm
- A = Position of the hole from the edge of the glass
- Security cylinder with rotary disc
- Locks may be supplied : - on same number
- on key chart
- Number of keys to be indicated when ordering
- May be combined with locks series
1460, 1461, 1462, 1463, 1465, 1466, 1467, 1468
- Supplied with 2 keys

1466.**.0

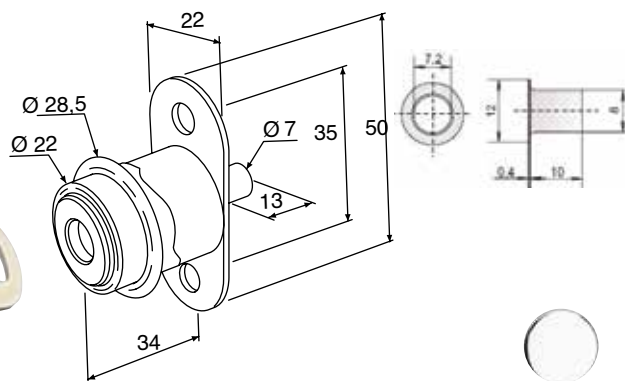

Références / References



Chromé brillant
Bright chromium

Serrure de sécurité à poussoir
Security push button lock

1466.30.0

- Pour bois ou mélaminé de 33 mm d'épaisseur maxi
- Montage sur trou Ø 23 mm
- Ouverture à la clé par décondamnation du bouton poussoir
- Clé réversible
- Fermeture par simple pression sur le bouton poussoir
- Cylindre de sécurité à disques rotatifs
- Possibilité de serrures : - sur même numéro
- sur organigramme
- Nombre de clés à définir à la commande
- Combinaison de clé avec les serrures
1460, 1461, 1462, 1463, 1464, 1465, 1467, 1468
- Livrée avec 1 gâche pour pêne axial, 2 clés en version variée

- For wood or particle board, max 33 mm thick
- Fits onto Ø 23 mm hole
- Unlocking with the key
- Reversible key
- Locking by pressing push button
- Security cylinder with rotary disc
- Locks may be supplied : - on same number
- on key chart
- Number of keys to be indicated when ordering
- May be combined with locks series
1460, 1461, 1462, 1463, 1464, 1465, 1467, 1468
- Supplied with 1 keep, 2 keys

1465.**.0

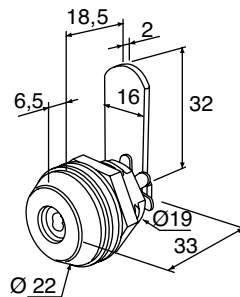

Chromé brillant
Bright chromium

Références / References



Serrure de sécurité à came batteuse
Security cam lock

1465.30.0

- Montage sur trou Ø 20 mm
- Clé prisonnière
- Clé réversible
- Cylindre de sécurité à disques rotatifs
- Possibilité de serrures : - sur même numéro
- sur organigramme
- Nombre de clés à définir à la commande
- Combinaison de clé avec les serrures
1460, 1461, 1462, 1463, 1464, 1466, 1467, 1468
- Livrée avec 2 clés en version variée, 1 came lg 32 mm
(à l'axe de cylindre)

- Fits onto Ø 20 mm hole
- Lock with captive key
- Reversible key
- Security cylinder with rotary disc
- Locks may be supplied : - on same number
- on key chart
- Number of keys to be indicated when ordering
- May be combined with locks series
1460, 1461, 1462, 1463, 1464, 1466, 1467, 1468
- Supplied with 2 keys, 1 cam 32 mm long (from the cylinder axis).

1467.**.0

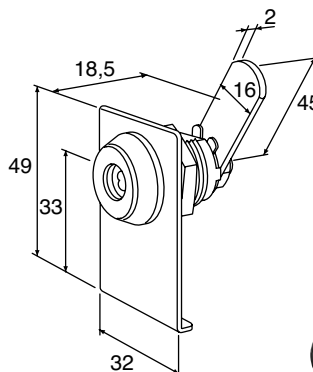

Chromé brillant
Bright chromium

Références / References



Serrure de sécurité à came batteuse
Security cam lock

1467.30.0

- Montage sur trou Ø 20 mm
- Clé prisonnière
- Clé réversible
- Cylindre de sécurité à disques rotatifs
- Possibilité de serrures : - sur même numéro
- sur organigramme
- Nombre de clés à définir à la commande
- Combinaison de clé avec les serrures
1460, 1461, 1462, 1463, 1464, 1465, 1466, 1468
- Livrée avec 2 clés en version variée, 1 came lg 45 mm
(à l'axe de cylindre)
- Saillie de la came 12 mm

- Fits onto Ø 20 mm hole
- Lock with captive key
- Reversible key
- Security cylinder with rotary disc
- Locks may be supplied : - on same number
- on key chart
- Number of keys to be indicated when ordering
- May be combined with locks series
1460, 1461, 1462, 1463, 1464, 1465, 1466, 1468
- Supplied with 2 keys, 1 cam 45 mm long (from the cylinder axis)
- Projection of the cam 12 mm

Serrures
de sécurité à came
batteuse pour
porte en verre
Security showcase
cam locks for glass
door

1461.**.0

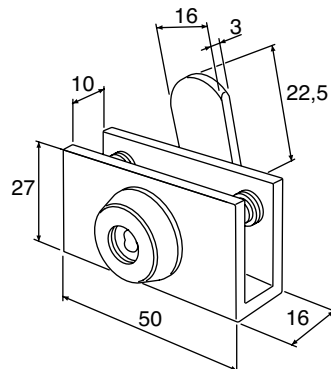
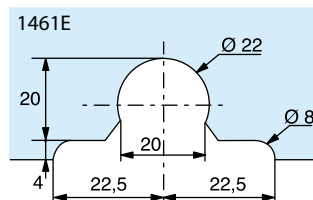

Chromé brillant
Bright chromium

Références / References



Serrure de sécurité à came batteuse
Security cam lock

1461.30.0

- Montage sur encoche 1461E
- Clé prisonnière
- Clé réversible
- Cylindre de sécurité à disques rotatifs
- Possibilité de serrures : - sur même numéro
- sur organigramme
- Nombre de clés à définir à la commande
- Combinaison de clé avec les serrures
1460, 1461, 1462, 1463, 1464, 1465, 1466, 1468
- Livrée avec 2 clés en version variée, 1 came lg 22.5 mm
(à l'axe de cylindre),
- Saillie de la came 9 mm

- For notch 1461E
- Lock with captive key
- Reversible key
- Security cylinder with rotary disc
- Locks may be supplied : - on same number
- on key chart
- Number of keys to be indicated when ordering
- May be combined with locks series
1460, 1461, 1462, 1463, 1464, 1465, 1466, 1467, 1468
- Supplied with 2 keys, 1 cam 22.5 mm long (from the cylinder axis),
- Projection of the cam 9 mm

1468.**.0

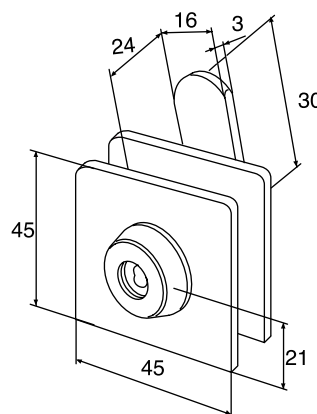
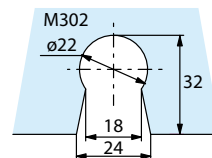

Chromé brillant
Bright chromium

Références / References



Serrure de sécurité à came batteuse
Security cam lock

1468.30.0

- Montage sur encoche M302
- Clé prisonnière
- Clé réversible
- Cylindre de sécurité à disques rotatifs
- Possibilité de serrures : - sur même numéro
- sur organigramme
- Nombre de clés à définir à la commande
- Combinaison de clé avec les serrures
1460, 1461, 1462, 1463, 1464, 1465, 1466, 1467
- Livrée avec 2 clés en version variée, 1 came lg 30 mm
(à l'axe de cylindre),
- Saillie de la came 9 mm

- For notch M302
- Lock with captive key
- Reversible key
- Security cylinder with rotary disc
- Locks may be supplied : - on same number
- on key chart
- Number of keys to be indicated when ordering
- May be combined with locks series
1460, 1461, 1462, 1463, 1464, 1465, 1466, 1467
- Supplied with 2 keys, 1 cam 30 mm long (from the cylinder axis),
- Projection of the cam 9 mm

Serrures
de sécurité à came
batteuse pour
porte en verre
*Security showcase
cam locks for glass
door*



Image d'illustration

Pentures et pivots
de vitrine
*Showcase hinges
and pivot clips*

3269.**.0

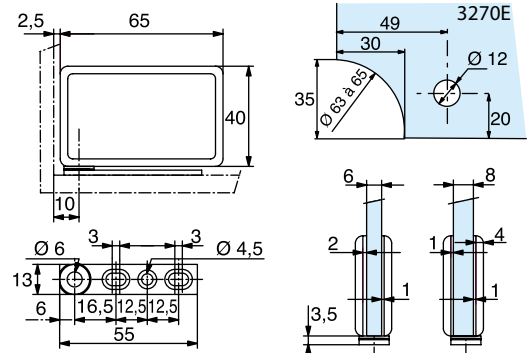

Références / References



Chromé brillant
Bright chromium



Chromé mat
Matt chromium



Doré
Gold plated

Penture de vitrine haute et basse
Top and bottom showcase hinges

3269.30.0

3269.31.0

3269.40.0

- Montage sur encoche 3270E
- Serrage par contreplaqué
- Montage sur platine en applique

- For notch 3270E
- Tightened by plate
- Mounted on surface mounted wall plate

LES + PRODUITS
The + product

Qualité de finition
Esthétique

High quality finishes
Aesthetic

3270.**.0

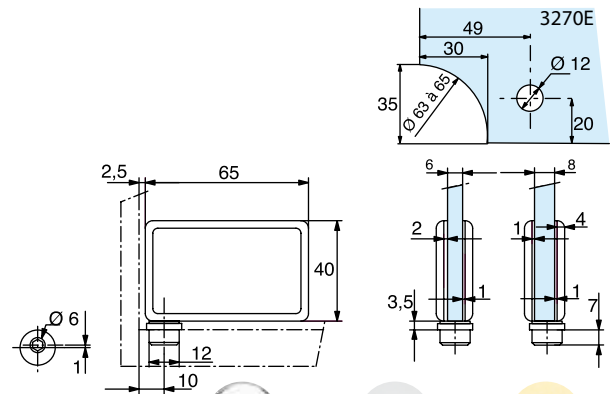

Références / References



Chromé brillant
Bright chromium



Chromé mat
Matt chromium



Doré
Gold plated

Penture de vitrine haute et basse
Top and bottom showcase hinges

3270.30.0

3270.31.0

3270.40.0

- Montage sur encoche 3270E
- Serrage par contreplaqué
- Penture équipée d'un axe rétractable facilitant la pose
- Pivot encastrable à perçage décentré pour parfaire l'ajustement

- For notch 3270E
- Tightened by plate
- With retractable pin for easier assembly
- Mortised pivot with off centre hole for better fit

5630.**.0

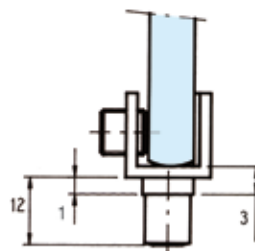
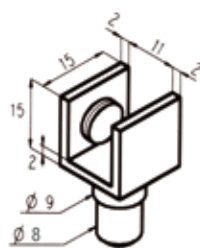

Références / References



Chromé brillant
Bright chromium



Chromé mat
Matt chromium

Pince à pivot 15 x 15 mm ouverture de 11 mm
Pivot clip 15 x 15 mm 11 mm opening

5630.30.0

5630.31.0

- Montage sans encoche
- Utilisation en haut et en bas du volume
- Profil laiton
- Serrage par 1 vis à embout
- Unité de vente : 10 pinces

- No notch required
- Used at top and bottom of panel
- Brass profile
- Tightened with one screw
- Sold in pack of 10

5630.**.1

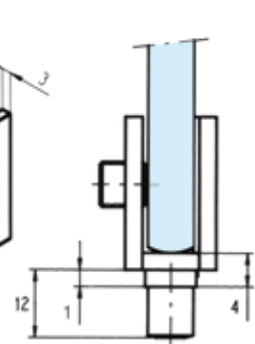
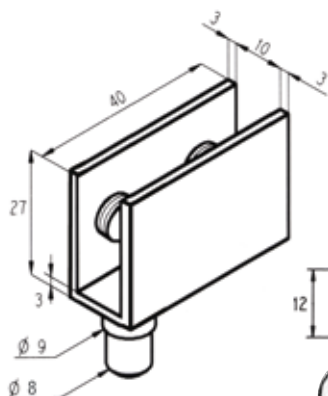

Références / References



Chromé brillant
Bright chromium



Chromé mat
Matt chromium

Pince à pivot 27 x 40 mm ouverture de 10 mm
Pivot clip 27 x 40 mm 10 mm opening

5630.30.1

5630.31.1

- Montage sans encoche
- Utilisation en haut et en bas du volume
- Profil laiton
- Serrage par 2 vis à embout
- Unité de vente : 1 pince haute et 1 pince basse

- No notch required
- Used at top and bottom of panel
- Brass profile
- Tightened with 2 screws
- Sold in pairs : 1 top and bottom clip

5630.**.8

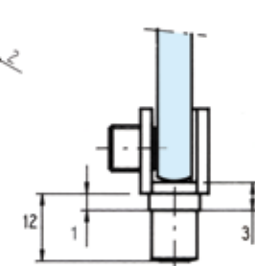
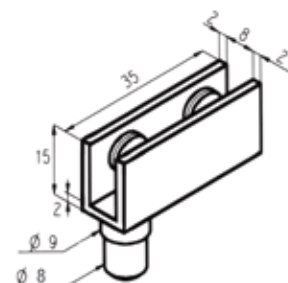

Références / References



Chromé brillant
Bright chromium



Chromé mat
Matt chromium

Pince à pivot 15 x 35 mm ouverture de 8 mm
Pivot clip 15 x 35 mm 8 mm opening

5630.30.8

5630.31.8

- Montage sans encoche
- Utilisation en haut et en bas du volume
- Profil laiton
- Serrage par 2 vis à embout
- Unité de vente : 1 pince haute et 1 pince basse

- No notch required
- Used at top and bottom of panel
- Brass profile
- Tightened with 2 screws
- Sold in pairs : 1 top and bottom clip

Pentures et pivots
de vitrine
Showcase hinges
and pivot clips

Pinces charnières
et charnières
à contreplaques
pour vitrine
Clip hinges and
wall plate hinges
for showcases

5500.**.2

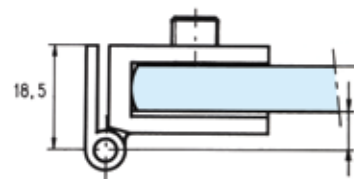
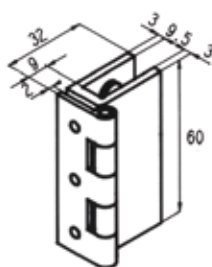

Références / References

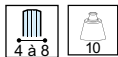

Pince charnière simple 60 x 32 mm
60 x 32 mm single clip hinge



Chromé brillant
Bright chromium

5500.30.2

- Montage sans encoche
- Dimensions maximum des volumes 130 x 45 cm
- Profil laiton, axe inox moleté
- Serrage par 3 vis à embout
- Unité de vente : 2 pinces charnières simples

- No notch required
- Maximum panel size 130 x 45 cm
- Brass profile and milled stainless steel pin
- Tightened with 3 round end screws
- Sold in pack of 2

LES + PRODUITS
The + product

Gamme complète

Complete range

5500.**.3

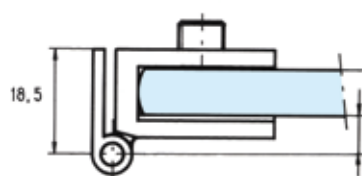
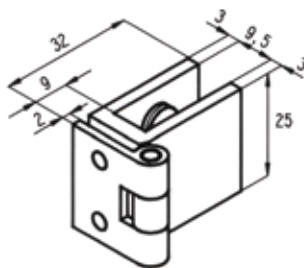

Références / References



Pince charnière simple 25 x 32 mm
25 x 32 mm single clip hinge



Chromé brillant
Bright chromium

5500.30.3

- Montage sans encoche
- Dimensions maximum des volumes 60 x 40 cm
- Profil laiton, axe inox moleté
- Serrage par 2 vis à embout
- Unité de vente : 2 pinces charnières simples

- No notch required
- Maximum panel size 60 x 40 cm
- Brass profile and milled stainless steel pin
- Tightened with 2 round end screws
- Sold in pack of 2

5500.**.4

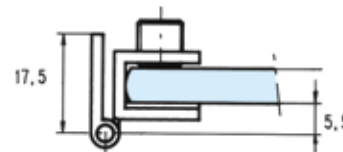
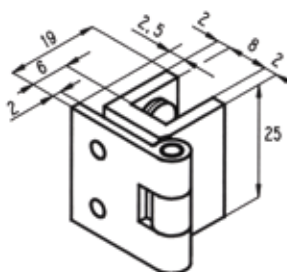

Références / References



Pince charnière simple 25 x 19 mm
25 x 19 mm single clip hinge



Chromé brillant
Bright chromium

5500.30.4

- Montage sans encoche
- Dimensions maximum des volumes 40 x 30 cm
- Profil laiton, axe inox moleté
- Serrage par 2 vis à embout
- Unité de vente : 2 pinces charnières simples

- No notch required
- Maximum panel size 40 x 30 cm
- Brass profile and milled stainless steel pin
- Tightened with 2 round end screws
- Sold in pack of 2

5500.**.0

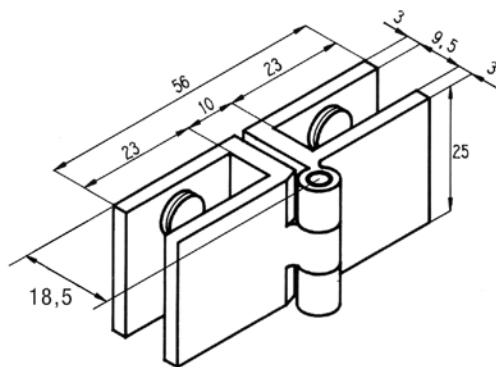

Références / References



Pince charnière double 25 x 56 mm
25 x 56 mm double clip hinge



Chromé brillant
Bright chromium

5500.30.0

- Montage sans encoche
- Dimensions maximum des volumes 80 x 40 cm
- Profil laiton, axe inox moleté
- Serrage par 2 vis à embout coté opposé au nœud d'articulation
- Unité de vente : 4 pinces charnières doubles

- No notch required
- Maximum panel size 80 x 40 cm
- Brass profile and milled stainless steel pin
- Tightened by 2 round end screws on opposite side to hinge pin
- Sold in pack of 4

5500.**.1

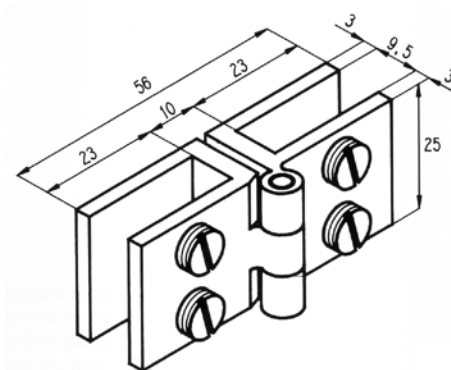

Références / References



Pince charnière double 25 x 56 mm
25 x 56 mm double clip hinge



Chromé brillant
Bright chromium

5500.30.1

- Montage sans encoche
- Dimensions maximum des volumes 80 x 40 cm
- Profil laiton, axe inox moleté
- Serrage par 2 vis à embout coté nœud d'articulation
- Unité de vente : 4 pinces charnières doubles

- No notch required
- Maximum panel size 80 x 40 cm
- Brass profile and milled stainless steel pin
- Tightened by 2 round end screws on same side as hinge pin
- Sold in pack of 4

Pinces charnières
et charnières
à contreplaques
pour vitrine
Clip hinges and
wall plate hinges
for showcases

Pinces charnières
et charnières
à contreplaques
pour vitrine
Clip hinges and
wall plate hinges
for showcases

5500.**.8

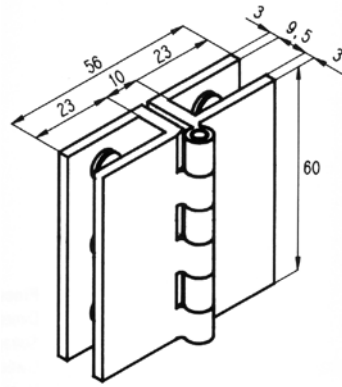

Références / References



Pince charnière double 60 x 56 mm
60 x 56 mm double clip hinge



Chromé brillant
Bright chromium

5500.30.8

- Montage sans encoche
- Dimensions maximum des volumes 130 x 45 cm
- Profil laiton, axe inox moleté
- Serrage par 3 vis à embout coté opposé au nœud d'articulation
- Unité de vente : 1 pince charnière double

- No notch required
- Maximum panel size 130 x 45 cm
- Brass profile and milled stainless steel pin
- Tightened by 2 round end screws on opposite side to hinge pin
- Sold per unit

5500.**.6

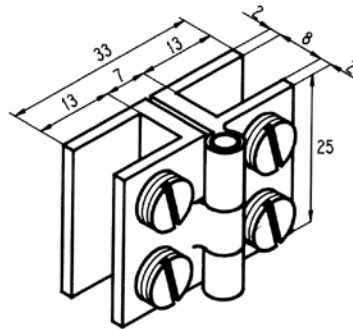

Références / References



Pince charnière double 25 x 33 mm
25 x 33 mm double clip hinge



Chromé brillant
Bright chromium

5500.30.6

- Montage sans encoche
- Dimensions maximum des volumes 40 x 30 cm
- Profil laiton, axe inox moleté
- Serrage par 2 vis à embout coté nœud d'articulation
- Unité de vente : 4 pinces charnières doubles

- No notch required
- Maximum panel size 40 x 30 cm
- Brass profile and milled stainless steel pin
- Tightened by 2 round end screws on same side as hinge pin
- Sold in pack of 4

5500.**.7

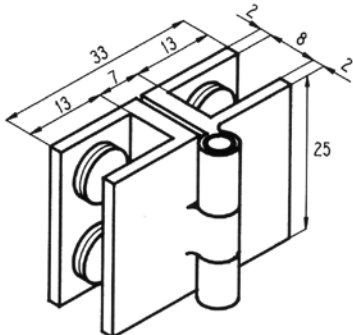

Références / References



Pince charnière double 25 x 33 mm
25 x 33 mm double clip hinge



Chromé brillant
Bright chromium

5500.30.7

- Montage sans encoche
- Dimensions maximum des volumes 40 x 30 cm
- Profil laiton, axe inox moleté
- Serrage par 2 vis à embout coté opposé au nœud d'articulation
- Unité de vente : 4 pinces charnières doubles

- No notch required
- Maximum panel size 40 x 30 cm
- Brass profile and milled stainless steel pin
- Tightened by 2 round end screws on opposite side to hinge pin
- Sold in pack of 4

5501.**.0

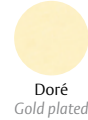
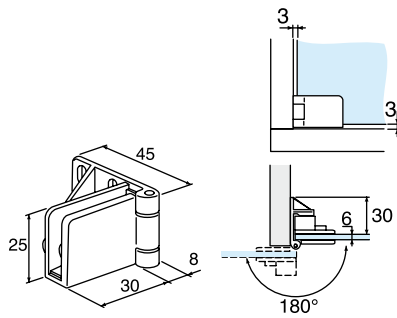

Références / References



Pince charnière simple avec blocage
Single clip hinge with blocking

5501.30.0

5501.40.0

- Montage sans encoche
- Blocage en position fermée
- Ouverture à 180°
- Dimensions maximum des volumes 50 x 30 cm
- Serrage par 1 vis à embout
- Unité de vente : 1 charnière haute et 1 charnière basse

- No notch required
- Blocking in closed position
- Opening through 180°
- Maximum panel size 50 x 30 cm
- Tightened by 1 round end screw
- Sold per pairs (top and bottom hinge).

5503.**.1

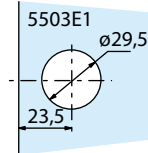
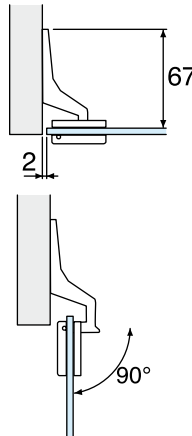
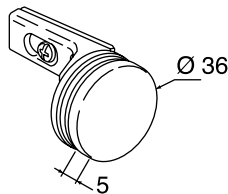

Références / References

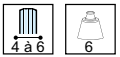

Charnière simple avec blocage
Round single hinge with blocking

5503.30.1

- Montage avec encoche 5503E1
- Blocage en position fermée
- Ouverture à 90°
- Unité de vente : 2 charnières

- For notch 5503E1
- Blocking in closed position
- Opening through 90°
- Sold in pairs

5503.**.2

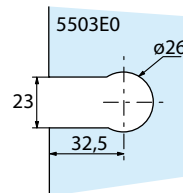
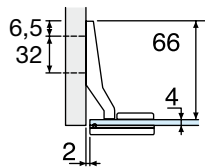
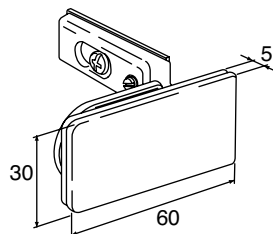

Références / References



Charnière simple rectangulaire avec blocage pour porte encastrée
Rectangular hinge with blocking point for inserted panel

5503.30.2

5503.40.2

- Montage avec encoche 5503E0
- Blocage en position fermée
- Ouverture à 130°
- Unité de vente : 2 charnières

- For notch 5503E0
- Blocking in closed position
- Opening through 130°
- Sold per pairs

Pinces charnières
et charnières
à contreplaques
pour vitrine
Clip hinges and
wall plate hinges
for showcases

Pinces charnières
et charnières
à contreplaques
pour vitrine
Clip hinges and
wall plate hinges
for showcases

5503.**.4

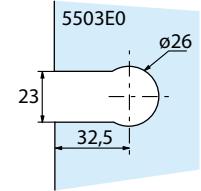
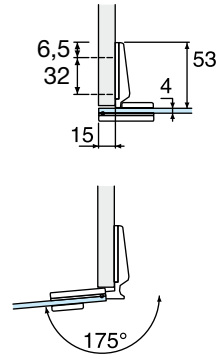
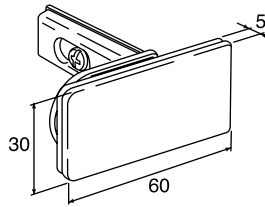

Références / References

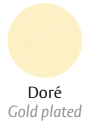

Charnière simple rectangulaire avec blocage pour porte à recouvrement
Rectangular hinge with blocking point for overlapping door

5503.30.4

5503.40.4

- Montage avec encoche 5503E0
- Recouvrement de 15 mm
- Blocage en position fermée
- Ouverture à 175°
- Unité de vente : 2 charnières

- For notch 5503E0
- 15 mm overlap
- Blocking in closed position
- Opening through 175°
- Sold in pairs



5502.**.0

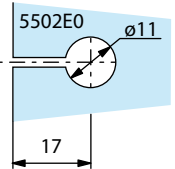
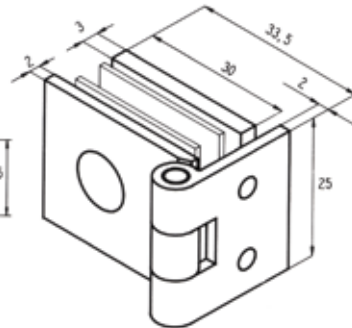
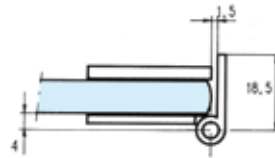

Références / References



Charnière 25 x 33.5 mm à contreplaqué
Wall plate hinge 25 x 33.5 mm

5502.30.0

5502.31.0

- Montage avec encoche 5502E0
- Profil laiton, axe inox moleté
- Serrage par 1 vis à douille réversible
- Unité de vente : 2 charnières simples

- For notch 5502E0
- Brass profile and milled stainless steel pin
- Tightened with 1 reversible tipped screw
- Sold in pack of 2

5502.**.0SQ

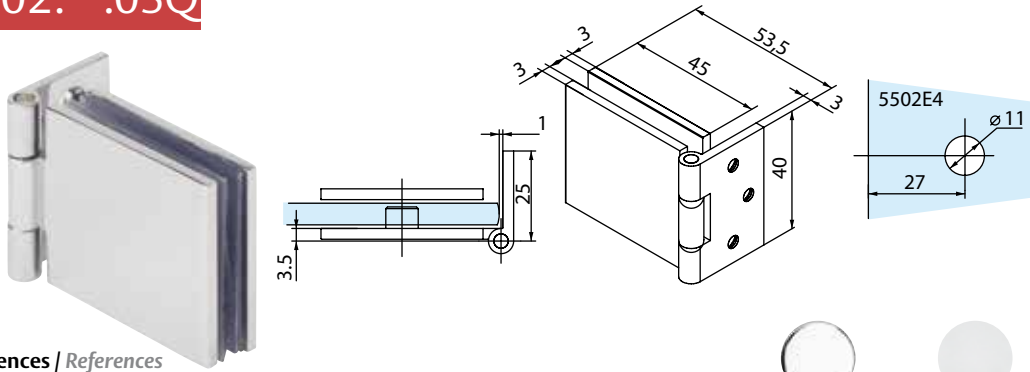

Références / References



Charnière simple carré 40 x 54 mm
Square hinge 40 x 54 mm

Chromé brillant
Bright chromium

Chromé mat
Matt chromium

5502.30.0SQ

5502.31.0SQ

- Montage avec encoche 5502E4
- Profil laiton, axe inox moleté
- Unité de vente : 2 charnières simples

- For notch 5502E4
- Brass profile and milled stainless steel pin
- Sold in pack of 2

5502.**.0AR

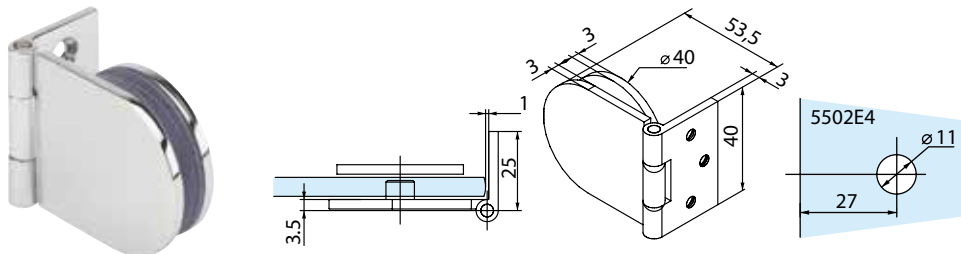

Références / References



Charnière simple arrondie 40 x 54 mm
Single hinge rounded 40 x 54 mm

Chromé brillant
Bright chromium

Chromé mat
Matt chromium

5502.30.0AR

5502.31.0AR

- Montage avec encoche 5502E4
- Profil laiton, axe inox moleté
- Unité de vente : 2 charnières simples

- For notch 5502E4
- Brass profile and milled stainless steel pin
- Sold in pack of 2

Pincas charnières
et charnières
à contreplaques
pour vitrine
Clip hinges and
wall plate hinges
for showcases

Pinces charnières
et charnières
à contreplaques
pour vitrine
Clip hinges and
wall plate hinges
for showcases

5502.**.2

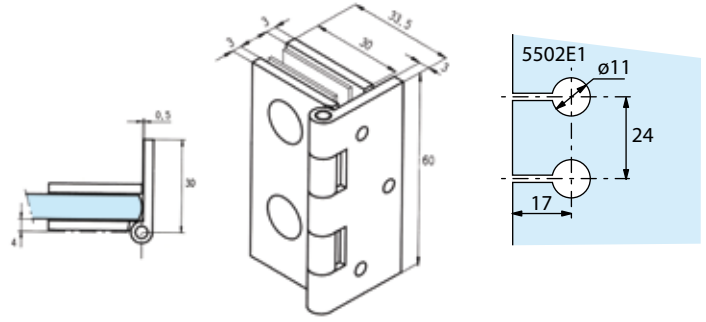

Références / References



Charnière 60 x 33.5 mm à contreplaque
Wall plate hinge 60 x 33.5 mm

5502.30.2

5502.31.2

- Montage avec encoche 5502E1
- Profil laiton, axe inox moleté
- Serrage par 2 vis à douille réversible
- Unité de vente : 2 charnières simples

- For notch 5502E1
- Brass profile and milled stainless steel pin
- Tightened with 2 reversible tipped screws
- Sold in pack of 2

5502.**.1

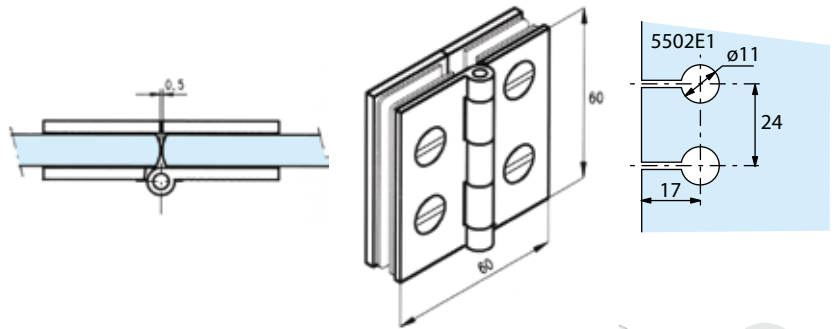

Références / References



Charnière double à contreplaque 60 x 60 mm
Glass to glass hinge 60 x 60 mm

5502.30.1

5502.31.1

- Montage avec encoche 5502E1
- Profil laiton, axe inox moleté
- Serrage par 2 vis à douille réversible
- Unité de vente : 2 charnières doubles

- For notch 5502E1
- Brass profile and milled stainless steel pin
- Tightened with 2 reversible tipped screws
- Sold in pack of 2

5502.**.3

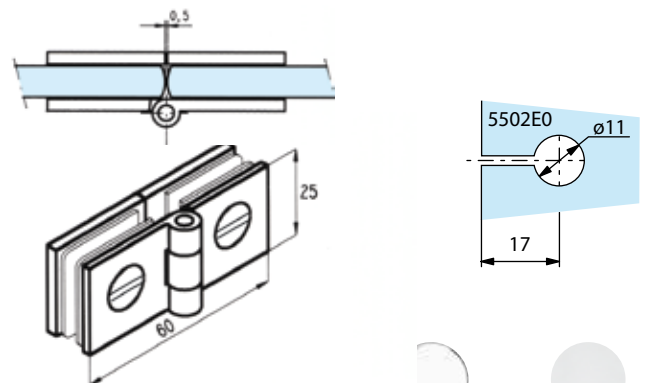

Références / References

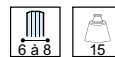

Charnière double à contreplaque 25 x 60 mm
Glass to glass hinge 25 x 60 mm

5502.30.3

5502.31.3

- Montage avec encoche 5502E0
- Profil laiton, axe inox moleté
- Serrage par 1 vis à douille réversible
- Unité de vente : 2 charnières doubles

- For notch 5502E0
- Brass profile and milled stainless steel pin
- Tightened with 1 reversible tipped screw
- Sold in pack of 2

5502.**.4

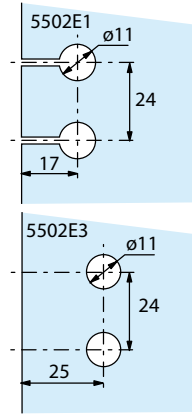
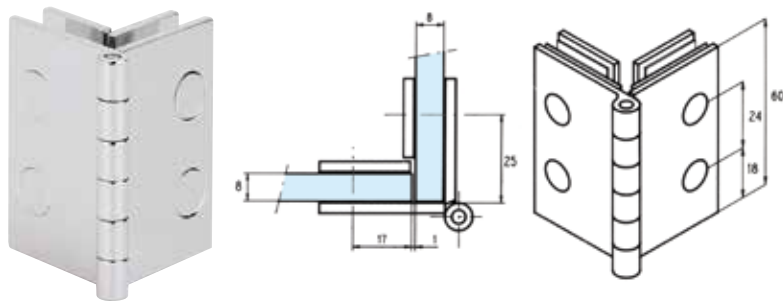

Pinces charnières
et charnières
à contreplaques
pour vitrine
Clip hinges and
wall plate hinges
for showcases

Références / References



Chromé brillant
Bright chromium



Chromé mat
Matt chromium

Charnière double d'angle à contreplaque 60 x 44 mm
Corner hinge 60 x 44 mm

5502.30.4

5502.31.4

- Montage avec encoche 5502E3 pour le volume fixe et 5502E1 pour le volume mobile
- Profil laiton, axe inox moleté
- Serrage par 2 vis à douille réversible
- Unité de vente : 1 charnière d'angle

- For notch 5502E3 for fixed panel and 5502E1 for mobile panel
- Brass profile and milled stainless steel pin
- Tightened with 2 reversible tipped screws
- Sold per unit

5502.**.5

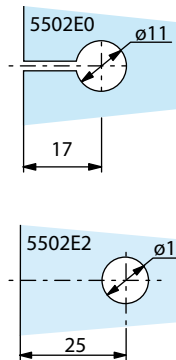
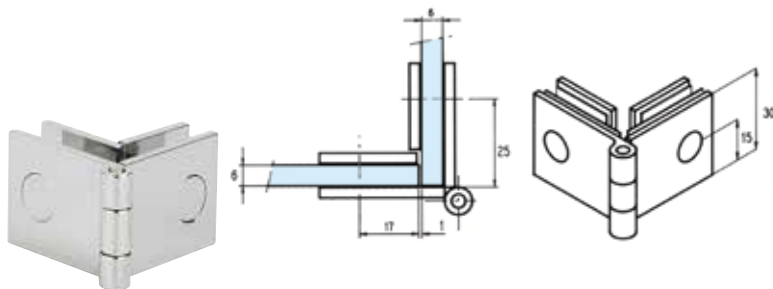

Références / References



Chromé brillant
Bright chromium



Chromé mat
Matt chromium

Charnière double d'angle à contreplaque 30x 44 mm
Corner hinge 30 x 44 mm

5502.30.5

5502.31.5

- Montage avec encoche 5502E2 pour le volume fixe et 5502E0 pour le volume mobile
- Profil laiton, axe inox moleté
- Serrage par 1 vis à douille réversible
- Unité de vente : 2 charnières d'angles

- For notch 5502E2 for fixed panel and 5502E0 for mobile panel
- Brass profile and milled stainless steel pin
- Tightened with 1 reversible tipped screws
- Sold in pack of 2

Pinces fixes
pour vitrine
Fixed clips for
showcase

5630.**.2

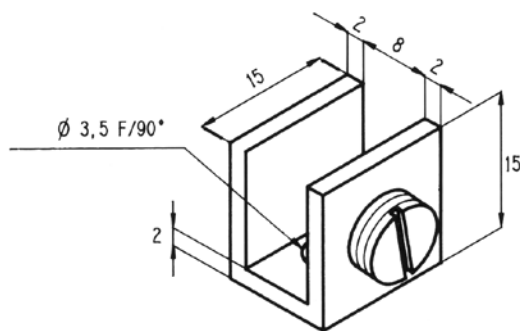

Chromé brillant
Bright chromium



Chromé mat
Matt chromium

Références / References



10 pinces fixes à visser 15 x 15 mm ouverture de 8 mm
10 fixed screw on clips 15 x 15 mm 8 mm opening

5630.30.2

5630.31.2

- Montage sans encoche
- Profil laiton
- Serrage par vis à embout

- No notch required
- Brass profile
- Tightened by round end screw



5630.**.3

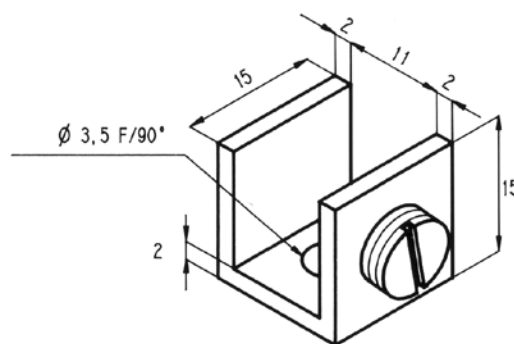

Chromé brillant
Bright chromium



Chromé mat
Matt chromium

Références / References



10 pinces fixes à visser 15 x 15 mm ouverture de 11 mm
10 fixed screw on clips 15 x 15 mm 11 mm opening.

5630.30.3

5630.31.3

- Montage sans encoche
- Profil laiton
- Serrage par vis à embout
- 5 kg pour 4 pièces

- No notch required
- Brass profile
- Tightened by round end screw

5630.**.4

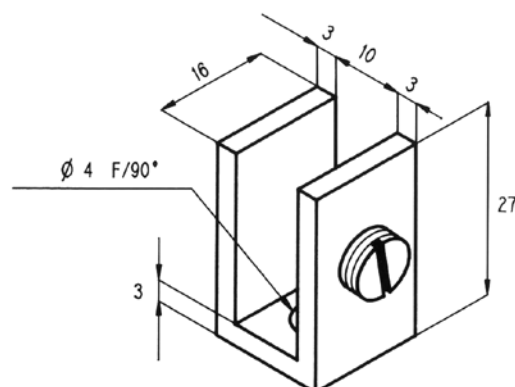

Chromé brillant
Bright chromium



Chromé mat
Matt chromium

Références / References



10 pinces fixes à visser 27 x 16 mm ouverture de 10 mm
10 fixed screw on clips 27 x 16 mm 10 mm opening

5630.30.4

5630.31.4

- Montage sans encoche
- Profil laiton
- Serrage par vis à embout
- 8 kg pour 4 pièces

- No notch required
- Brass profile
- Tightened by round end screw

5630.**.5

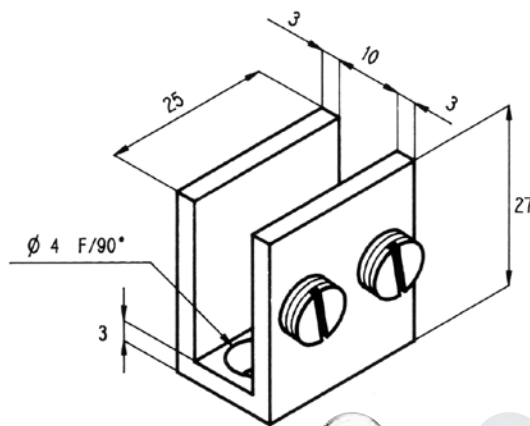

Pinces fixes
pour vitrine
Fixed clips for
showcase

Références / References



Chromé brillant
Bright chromium



Chromé mat
Matt chromium

4 pinces fixes à visser 27 x 25 mm ouverture de 10 mm
4 fixed screw on clips 27 x 25 mm 10 mm opening

5630.30.5

5630.31.5

- Montage sans encoche
- Profil laiton
- Serrage par vis à embout
- 12 kg pour 4 pièces

- No notch required
- Brass profile
- Tightened by round end screw

5630.**.6

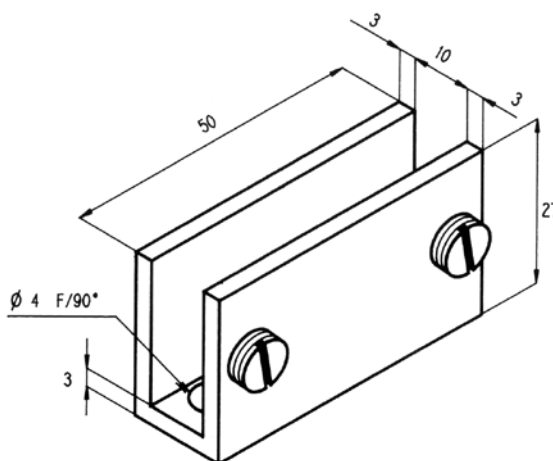

Références / References



Chromé brillant
Bright chromium



Chromé mat
Matt chromium

2 pinces fixes à visser 27 x 50 mm ouverture de 10 mm
2 fixed screw on clips 27 x 50 mm 10 mm opening

5630.30.6

5630.31.6

- Montage sans encoche
- Profil laiton
- Serrage par vis à embout
- 15 kg pour 4 pièces

- No notch required
- Brass profile
- Tightened by round end screw

Taquets simples
de vitrine
Single showcases
brackets

3277.**.0

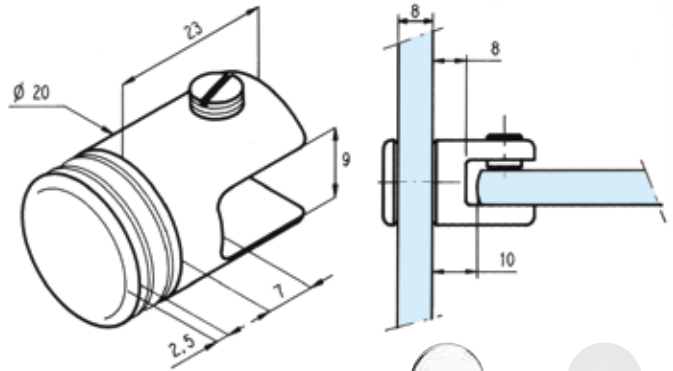

Références / References



4 taquets simples Ø 20 mm
4 single brackets 20mm Ø

3277.30.0

3277.31.0



3276.**.0

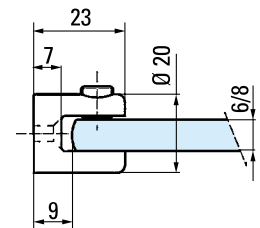
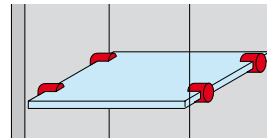

Références / References



4 taquets simples Ø 20 mm
4 single brackets 20mm Ø

3276.30.0

3276.31.0

• Livré avec vis de fixation et cheville

• Supplied with fastening screw and plug

3278.**.0

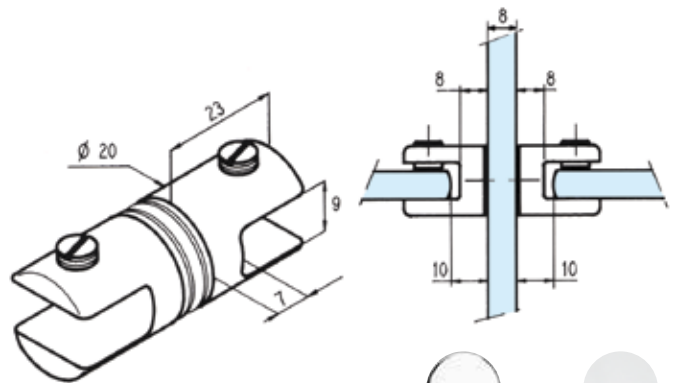

Références / References



2 taquets doubles Ø 20 mm
2 double brackets 20mm Ø

3278.30.0

3278.31.0

5660.**.0

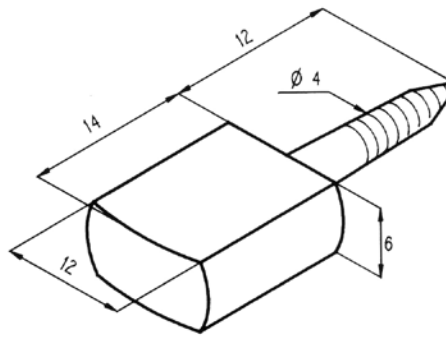

Références / References



10 taquets à visser 14 x 12 mm
10 bookshelf brackets 14 x 12 mm



Chromé brillant
Bright chromium

5660.30.0

5660.**.5

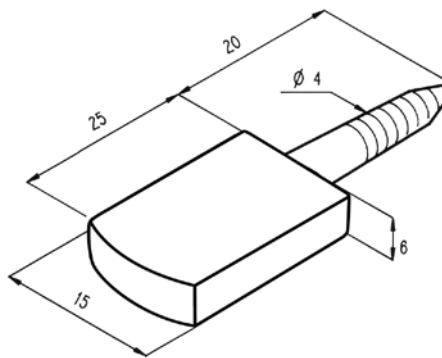

Références / References



10 taquets à visser 25 x 15 mm
10 bookshelf brackets 25 x 15 mm



Chromé brillant
Bright chromium

5660.30.5

5660.**.6

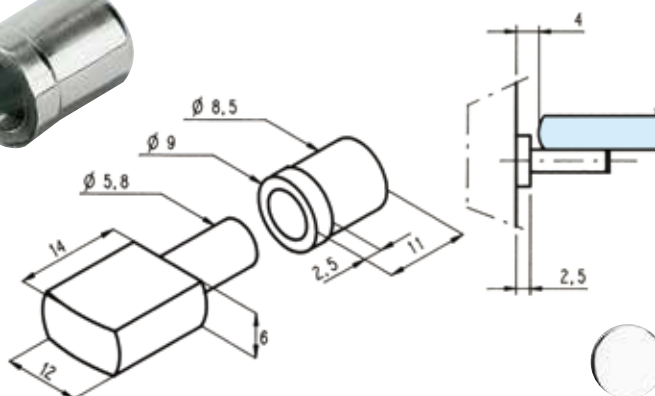
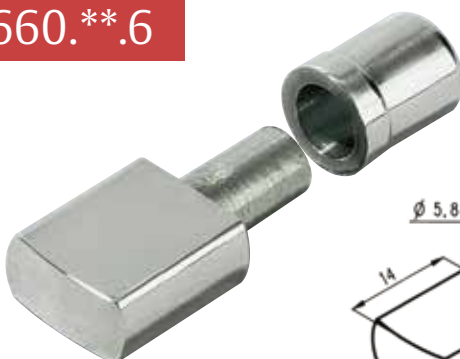

Références / References



10 taquets à douille 14 x 12 mm
10 bookshelf brackets 14 x 12 mm with tipped



Chromé brillant
Bright chromium

5660.30.6

Taquets
de bibliothèque
Bookshelf brackets

Pinces de fixation
et pieds à platine
*Partition clips and
plate stands*

5504.**.0BR

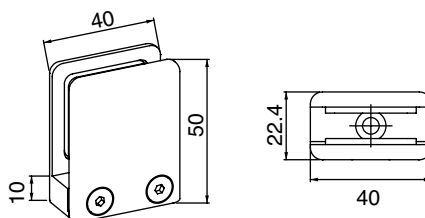

Références / References



Pince de milieu 40 x 50 mm
Centre clip 40 x 50 mm



Chromé brillant
Bright chromium



Chromé mat
Matt chromium

5504.30.0BR

5504.31.0BR

- Montage sans encoche
- Talon percé et fraisé pour vis de Ø 5 mm
- Adaptation possible sur les pieds à platine réf 5505

- No notch required
- Drilled and countersunk heel for 5 mm Ø screws
- Can be fitted on plate stand ref.5505

5504.**.3BR

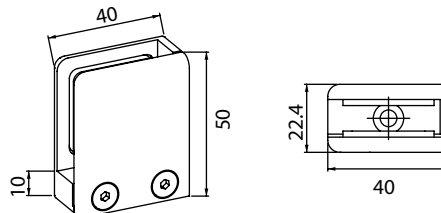

Références / References



Pince à talon droit 40 x 50 mm
Right heel clip 40 x 50 mm



Chromé brillant
Bright chromium



Chromé mat
Matt chromium

5504.30.3BR

5504.31.3BR

- Montage sans encoche
- Talon percé et fraisé pour vis de Ø 5 mm
- Adaptation possible sur les pieds à platine réf 5505

- No notch required
- Drilled and countersunk heel for 5 mm Ø screws
- Can be fitted on plate stand ref.5505

5504.**.4BR

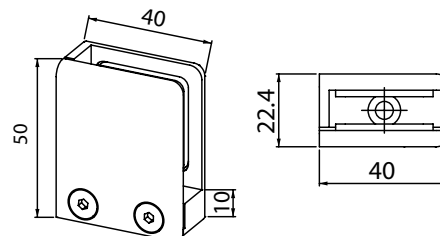

Références / References



Pince à talon gauche 40 x 50 mm
Left heel clip 40 x 50 mm



Chromé brillant
Bright chromium



Chromé mat
Matt chromium

5504.30.4BR

5504.31.4BR

- Montage sans encoche
- Talon percé et fraisé pour vis de Ø 5 mm
- Adaptation possible sur les pieds à platine réf 5505

- No notch required
- Drilled and countersunk heel for 5 mm Ø screws
- Can be fitted on plate stand ref.5505

5505.**.*

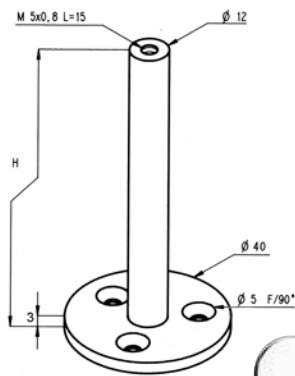

Références / References

Pied à platine
Plate stands

H = 80 mm	5505.30.1	5505.31.1
H = 100 mm	5505.30.2	5505.31.2
H = 120 mm	5505.30.3	5505.31.3

- Compatible avec les pinces 5504 et 5604
- Livré avec 3 vis de fixation

- Compatible with the clips series 5504 and 5604
- Supplied with 3 fastening screws

5506.**.*.4

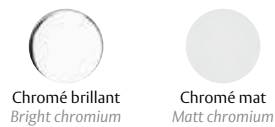
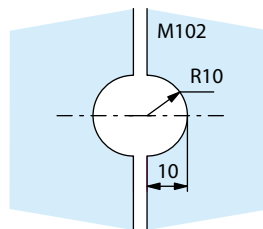
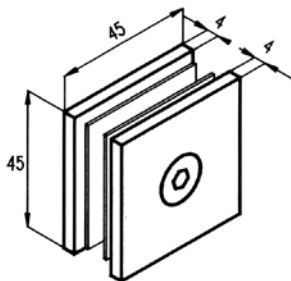

Références / References



Pièce de liaison pour 2 volumes fixes
Partition clip for 2 fixed panels

5506.30.4	5506.31.4
-----------	-----------

- Montage avec encoche M102

- Fits notch M102

Pinces de fixation
et pieds à platine
Partition clips and
plate stands

Pinces de fixation
et pieds à platine
Partition clips and
plate stands

5704.**.2

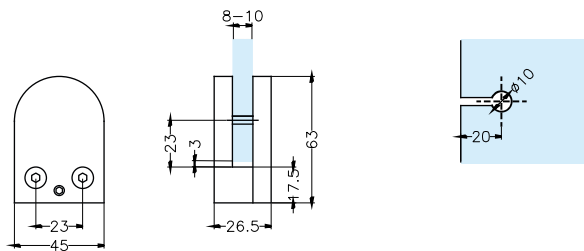

Références / References



Pince 44 x 62 mm
Partition clip 44 x 62 mm



5704.15.2

5704.16.2

LES + PRODUITS
The + product

PINCES INOX 304
MASSIF

304 Stainless steel
partition clip

5704.**.2R30

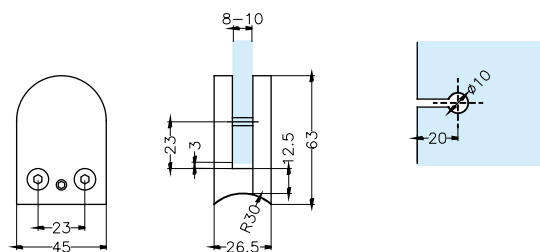

Références / References



Pince 44 x 62 mm pour tube Ø 60 mm
Partition clip 44 x 62 mm for mm Ø 60 tube



5704.15.2R30

5704.16.2R30

5704.**.3



Références / References



Pince 54 x 55 mm
Partition clip 54 x 55 mm



5704.15.3

5704.16.3

5704.**.3R30

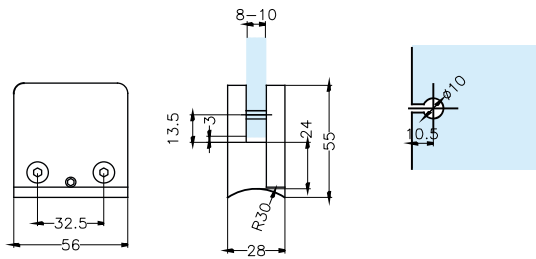

Références / References



Pince 54 x 55 mm pour tube Ø 60 mm
Partition clip 54 x 55 mm for mm Ø 60 tube



5704.15.3R30 5704.16.3R30

Pinces de fixation
et pieds à platine
Partition clips and
plate stands

5704.**.5

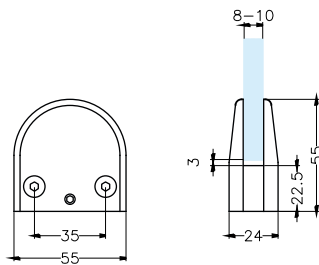

Références / References



Pince 55 x 55 mm
Partition clip 55 x 55 mm



5704.15.5 5704.16.5

5704.**.5R22

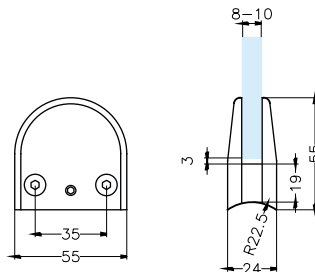

Références / References



Pince 55 x 55 mm pour tube Ø 45 ou 50 mm
Partition clip 55 x 55 mm for mm Ø 45 or 50 tube



5704.15.5R22 5704.16.5R22

Pattes à glaces, ro-
saces
Mirror clips, ro-
settes

5508.**.1

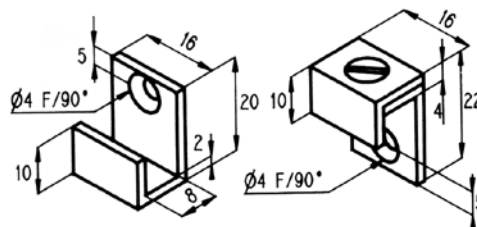
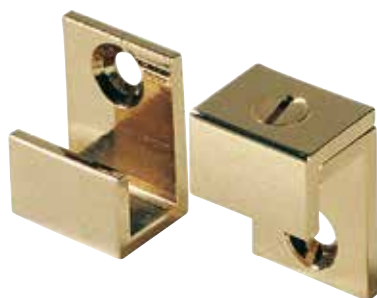

Références / References



Laiton poli
Polished brass



Chromé brillant
Bright chromium

4 pattes à glaces
4 mirror clips

5508.00.1

5508.30.1

- Livré avec vis de fixation et cheville
- Poids du miroir 18 kg maximum

• Supplied with fastening screw and plug

5508.**.2

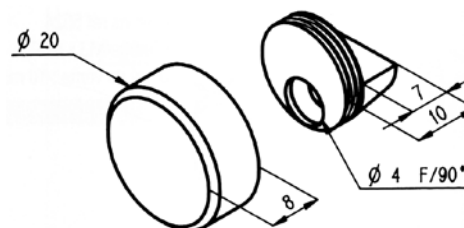

Références / References



Laiton poli
Polished brass



Chromé brillant
Bright chromium



Chromé mat
Matt chromium

4 pattes à glaces ronde Ø 20 mm
4 Mirror clips 20 mm Ø

5508.00.2

5508.30.2

5508.31.2

- Livré avec vis de fixation et cheville

• Supplied with fastening screw and plug

5516.**.3

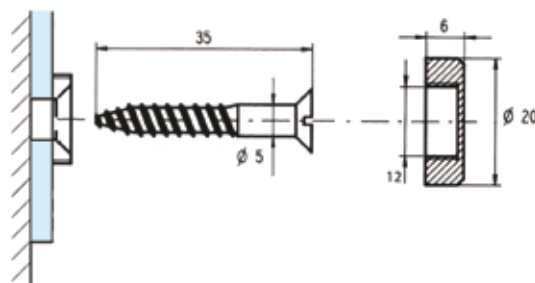

Références / References



Chromé brillant
Bright chromium



Chromé mat
Matt chromium

10 rosaces marbrier cylindrique
10 cylindrical marbled rosette

5516.30.3

5516.31.3

- Livré avec vis à bois 5 x 35

• Supplied with 5 x 35 woodscrew

5652.**.0

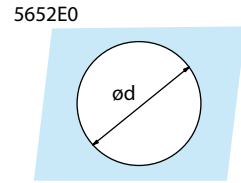
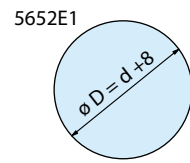
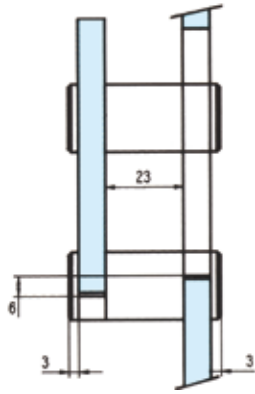
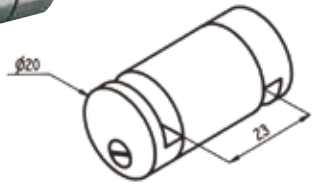

Chromé brillant
Bright chromium

Pinces entretoises
et supports
de tablette
Clips and
shelf supports

Références / References



Pince entretoise pour disque en verre
Spacer clip for glass disk speak holes

5652.30.0

• Montage sur encoches 5652E0 et 5652E1

• For notches 5652E0 et 5652E1

5631.**.0

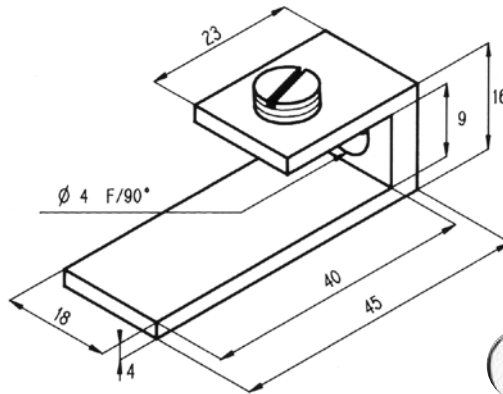

Chromé brillant
Bright chromium

Références / References



2 pinces fixes à ailes inégales
2 fixed clips with unequal wings

5631.30.0

• Livré avec vis de fixation et cheville

• Supplied with fastening screw and plug

5540.**.0

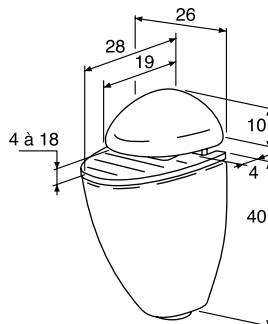

Chromé brillant
Bright chromium

Références / References



2 supports réglables pour tablette en verre
2 glass shelf supports with adjustable opening

5540.30.0

• Charge maxi 15 kg pour une tablette de 400 x 100 mm
• Livré avec vis de fixation et chevilles

• Maximum load 15 kg for a 400 x 100 mm shelf
• Supplied with screws and plugs

5541.**.0

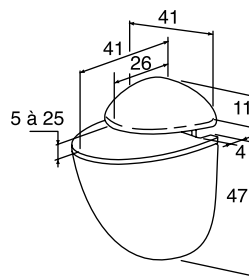

Références / References

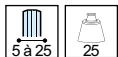

2 supports réglables pour tablette en verre
2 glass shelf supports with adjustable opening



Chromé brillant
Bright chromium

5541.30.0

- Charge maxi 25 kg pour une tablette de 800 x 150 mm
- Livré avec vis de fixation et chevilles

- *Maximum load 25 kg for a 800 x 150 mm shelf*
- *Supplied with screws and plugs*

5542.**.0

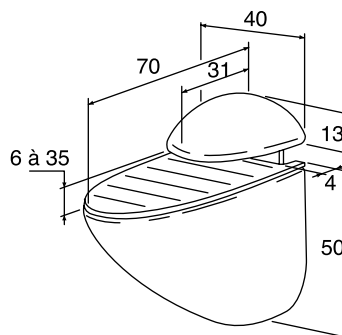

Références / References



2 supports réglables pour tablette en verre
2 glass shelf supports with adjustable opening



Chromé brillant
Bright chromium

5542.30.0

- Charge maxi 30 kg pour une tablette de 1000 x 200 mm
- Livré avec vis de fixation et chevilles

- *Maximum load 30 kg for a 1000 x 200 mm shelf*
- *Supplied with screws and plugs*

5543.**.0

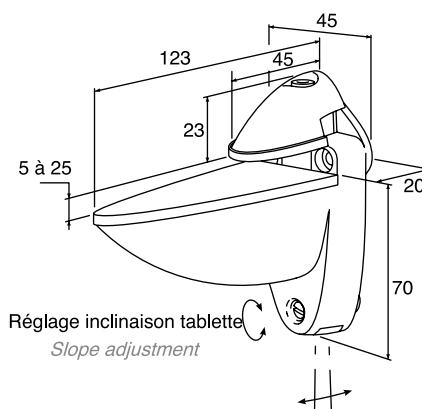

Références / References



2 supports réglables pour tablette en verre
2 glass shelf supports with adjustable opening



Argent
Silver

5543.10.0

- Charge maxi 35 kg pour une tablette de 1000 x 300 mm
- Livré avec vis de fixation et chevilles
- Vis de réglage d'inclinaison de tablette

- *Maximum load 35 kg for a 1000 x 300 mm shelf*
- *Supplied with screws and plugs*
- *Slope adjustment screw*

5545.**.0

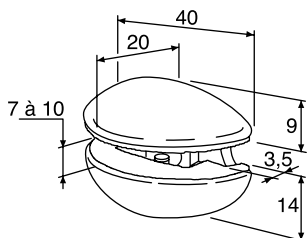

Références / References

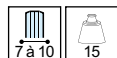

Chromé brillant
Bright chromium

2 supports réglables pour tablette en verre
2 glass shelf supports with adjustable opening

5545.30.0

- Charge maxi 15 kg pour une tablette de 400 x 100 mm
- Livré avec vis de fixation et chevilles

- Maximum load 15 kg for a 400 x 100 mm shelf
- Supplied with screws and plugs

5546.**.0

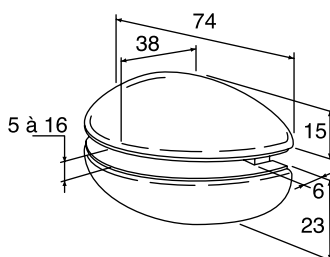

Références / References



Chromé brillant
Bright chromium

2 supports réglables pour tablette en verre
2 glass shelf supports with adjustable opening

5546.30.0

- Charge maxi 30 kg pour une tablette de 1000 x 200 mm
- Livré avec vis de fixation et chevilles

- Maximum load 30 kg for a 1000 x 200 mm shelf
- Supplied with screws and plugs

5548.**.0

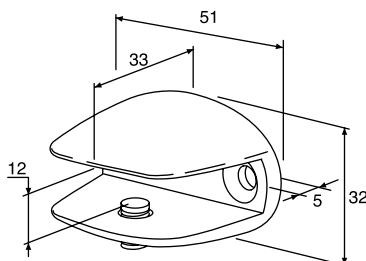

Références / References



Chromé brillant
Bright chromium

2 supports pour tablette en verre ouverture de 12 mm
2 glass shelf supports with 12 mm opening

5548.30.0

- Charge maxi 18 kg pour une tablette de 600 x 100 mm
- Livré avec vis de fixation et chevilles

- Maximum load 18 kg for a 600 x 100 mm shelf
- Supplied with screws and plugs

5550.**.0

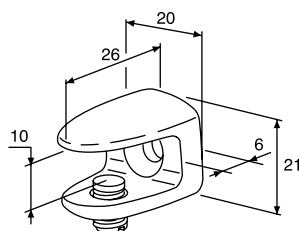

Références / References



Chromé brillant
Bright chromium



Doré
Gold plated

2 supports pour tablette d'angle ouverture de 10 mm
2 fixed angle supports with 10 mm opening

5550.30.0

5550.40.0

- Charge maxi 10 kg pour une tablette de 500 x 100 mm
- Livré avec vis de fixation et chevilles

- Maximum load 10 kg for a 500 x 100 mm shelf
- Supplied with screws and plugs

Entretoises INOX
pour plateau en
verre
*Stainless steel
spacer stands
for glass table top*



LES + PRODUITS

The + product

Tout inox

Stainless steel

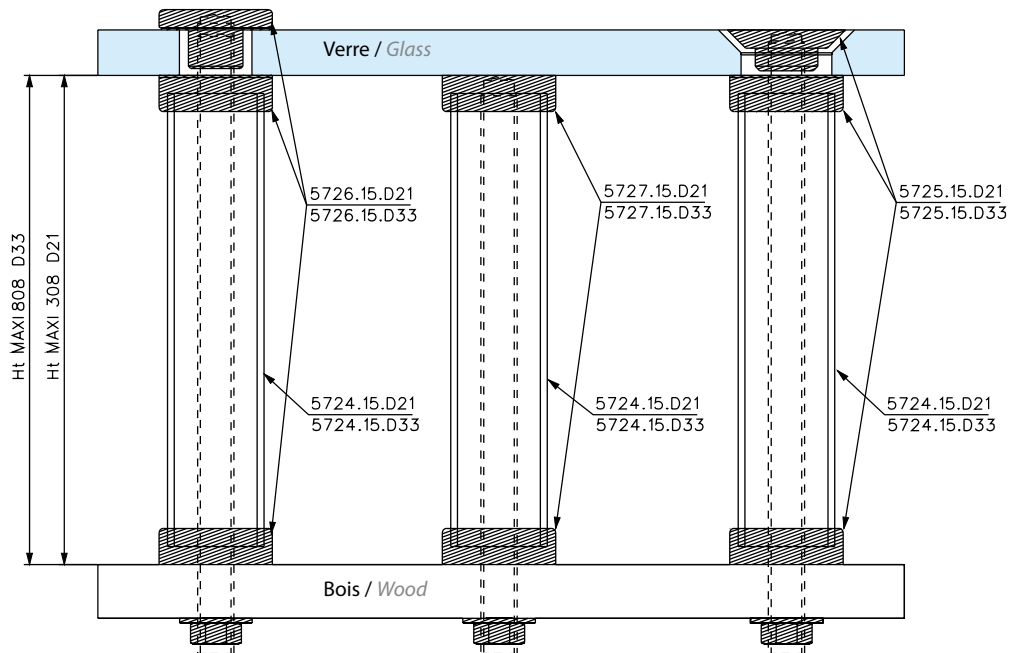

5724.15.D33

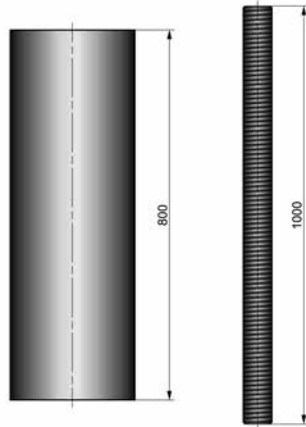

Entretoises INOX
pour plateau en
verre
Stainless steel
spacer stands
for glass table top

Tube inox \varnothing 33 mm longueur 800 mm avec tige filetée M8
33 mm \varnothing 800 mm long stainless steel tube with M8 threaded rod

5725.15.D33

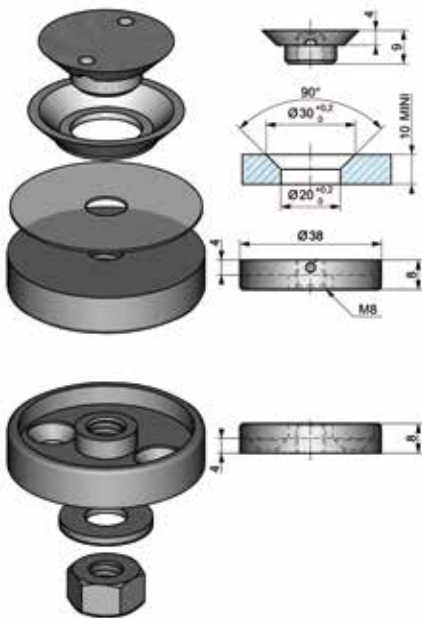

Ensemble haut et bas
pour tube \varnothing 33 mm cabochon supé-
rieur fraisé à visser
Top and bottom threaded
top countersunk head set
for 33 mm \varnothing tube

- Livré avec clé de serrage à ergot
- Delivered with tightening wrench

5726.15.D33

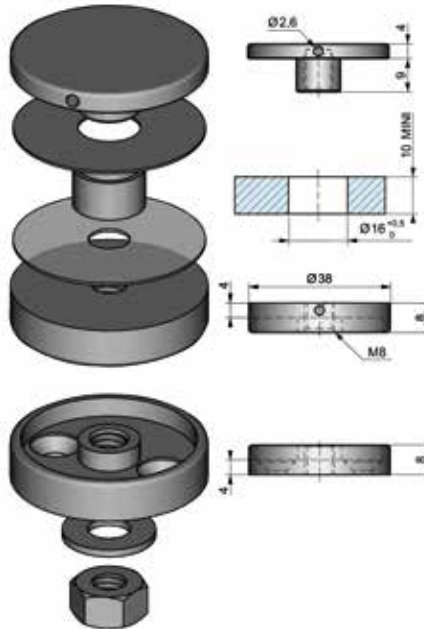

Ensemble haut et bas
pour tube \varnothing 33 mm cabochon supé-
rieur plat à visser
Top and bottom threaded
top flat head set for 33 mm \varnothing tube

5727.15.D33

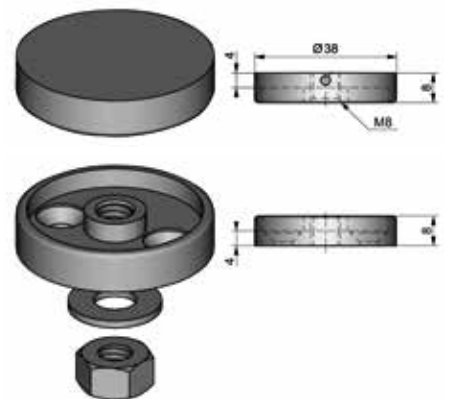

Ensemble haut et bas
pour tube \varnothing 33 mm cabochon supé-
rieur plat à coller
Top and bottom top glued head set
for 33 mm \varnothing tube

5725.15.0

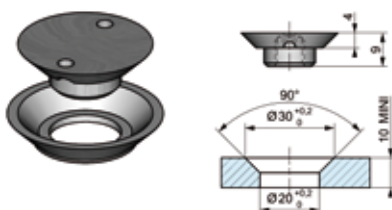

50 soucoupes inox avec bagues
50 stainless steel caps with rings

Entretoises INOX
pour plateau en
verre
*Stainless steel
spacer stands
for glass table top*

5724.15.D21

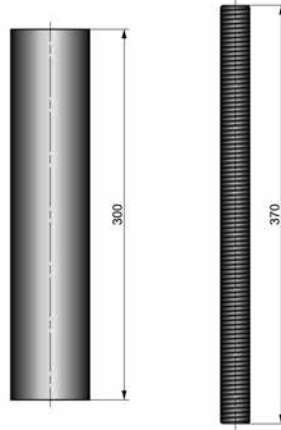

Tube inox Ø 21 mm longueur 300 mm avec tige filetée M8
21 mm Ø 300 mm long stainless steel tube with M8 threaded rod



LES + PRODUITS

The + product

Tout inox

Stainless steel

5725.15.D21

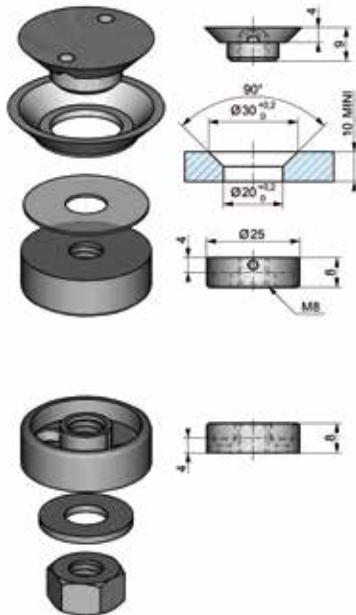

Ensemble haut et bas
pour tube Ø 21 mm cabochon supé-
rieur fraisé à visser
*Top and bottom threaded
top countersunk head set
for 21 mm Ø tube*

5726.15.D21

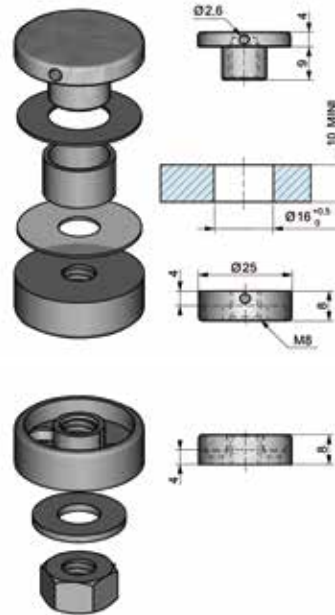

Ensemble haut et bas
pour tube Ø 21 mm cabochon supé-
rieur plat à visser
*Top and bottom threaded top flat head
set for 21 mm Ø tube*

5727.15.D21

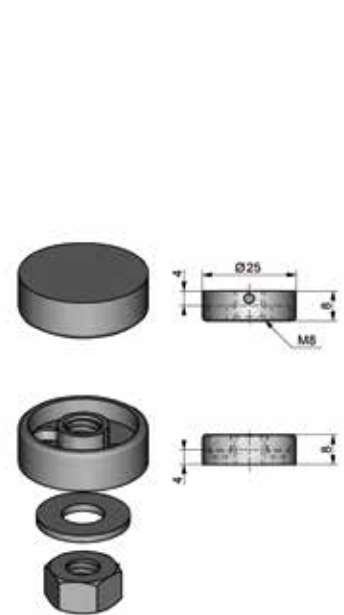

Ensemble haut et bas
pour tube Ø 21 mm cabochon supé-
rieur plat à coller
*Top and bottom top glued head set
for 21 mm Ø tube*

- Livré avec clé de serrage à ergot
- *Delivered with tightening wrench*

Légendes pictogrammes

List of pictograms



Article standard pour épaisseur de verre : 6 / 8 / 10 / 12 / 15 / 19
 Item standard for "X" mm glass thickness : 6 / 8 / 10 / 12 / 15 / 19



Peut être utilisé pour épaisseur de verre "X" mm, mais intercalaires spécifiques sont à commander
 Can be used for ·X· mm glass thickness but order specific gaskets



Poids maximum de la porte "X" kg
 Maximum door weight «X» kgs



Longueur d'extrusion en mm
 Extrusion length in mm



Diamètre en mm pour les trous à forer
 Diameter in mm of holes to be drilled



Arrêt à "X" : 90° / 105° / no = sans / A = réglable / ? = à renseigner lors de la commande
 Hold open «X» : 90° / 105° / no / A = adjustable / ? = specify when ordering



Qualité inoxydable
 Stainless steel quality



Axe / insert modèle Français (carré)
 French (square) spindle / insert



Axe / insert modèle allemand (rectangulaire)
 German (rectangular) spindle / insert



Axe / insert modèle italien (carré)
 Italian (square) spindle / insert

842.15	7	2720.**3L22	212	3262.**0R	223	4401.**0	77
934.99	9	27DI.99	8	3262.**2R	224	4460.**0	78
0309.**0	64	2800.66.4	104	3264.**0R	225	4461.**0	78
1300.**0	97	2800.66.5	104	3265.**0	242	4480.**0	79
1309.**0	97	2809.**4	157	3265.**0SQ	242	4481.**0	79
1353.**0	127	2810.**L3000	156	3266.**0	194	4501.**0	81
1358.**0	126	2810.10.*	157	3267.**0	194	4509.**0	82
1359.**0	127	2811.10.*	157	3269.**0	288	4509.**0	82
1435.**0	128	2812.**L3000	156	3270.**0	288	4550.**0	81
1439.**0	128	2813.12	158	3271.**0	124	4550.**4	81
1445.**0	121	28131.12	158	3272.**0	124	4550.**5	81
1446.**0	121	2814.**1	234	3273.**0	125	4555.**0	82
1446.**5	121	2814.**2	234	3276.**0	300	4555.**4	82
1447.**0	122	2814.**7	235	3277.**0	300	4555.**5	82
1448.**0	122	2814.99.3	234	3278.**0	300	4861.**0	119
1449.**0	122	2814.99.3CV	235	3280.**0	125	4862.**0	119
1450.**0	278	2814.99.4	234	3281.**0	125	4961.**0SQ	116
1452.**0	278	2814.99.4CV	235	3290.**0	195	4962.**0SQ	117
1454.**0	281	2814.99.5	235	3460.**0R	214	5500.**0	291
1455.**0	280	2815L***.**	62-159	3462.**0R	215	5500.**1	291
1456.**0	277	2816.13.3	250	3465.**0	243	5500.**2	290
1457.**0	280	2818.**2	248	3560.**0R	216	5500.**3	290
1459.**0	281	2818.**3	248	3560.**0RSQ	220	5500.**4	290
1460.**0	282	2819.**2	249	3561.**0R	217	5500.**6	292
1461.**0	286	2819.**3	249	3561.**0RSQ	221	5500.**7	292
1462.**0	282	2820.**1	200	3562.**0R	217	5500.**8	292
1462.**0C	283	2820.**2	202	3562.**0RSQ	221	5501.**0	293
1464.**0	284	2820.**3	203	3562.**2R	218	5502.**0	294
1465.**0	285	2820.**4	204	3565.**0	243	5502.**0AR	295
1466.**0	284	2820.**5	205	3660.**0RSQ	226	5502.**0SQ	295
1467.**0	285	2820.**6	206	3662.**0RSQ	227	5502.**1	296
1468.**0	286	2820.**7	207	3666.**0	195	5502.**2	296
1470.**0	276	2820.**9	208	3760.**0RSQCV	228	5502.**3	296
1471.**0	277	2827.**0	191	3762.**0RSQ	229	5502.**4	297
1479.**0	276	2858.10.V2	7	3764.**0RSQ	229	5502.**5	297
14HZ.99	9	2881.15.0	63-95	37E9.99	8	5503.**1	293
1651.**0	253	2881.15.0	95	4200.**0	107	5503.**2	293
1652.**0	254	2900.66.*	270	4201.**0	107	5503.**4	294
1652.**0D	254	2901.66.*	271	4201.31.5	107	5504.**0BR	302
1652.**0G	254	2902.66.*	272	4202.**0	112	5504.**3BR	302
1653.10.0	191	2903.66.3	272	4203.**0	108	5504.**4BR	302
1654.10.0	191	2927.**0	192	4205.**0	114	5505.**	303
1657.**0	253	3056.**0	245	4206.**0	113	5506.**4	247
1657.**0D12	255	3060.**0	236	4208.99.0	114	5506.**4	303
1657.**1	255	3062.**0	237	4300.**0	64	5508.**1	306
1657.**2SQ	255	3062.**0SQ	239	4301.**0	65	5508.**2	306
1658.**0	256	3065.**0	245	4306.**0	65	5516.**3	306
1658.**0D12	256	3066.**0	192	4307.**0	66	5540.**0	307
1658.**1D12	257	3069.**0	236	4309.**0	64-77	5541.**0	308
1658.**2SQ	256	3069.**0SQ	238	4310.**0	66	5542.**0	308
1659.**0	257	3085.**0	244	4311.**0	67	5543.**0	308
1660.**0	261	3160.**0RCV	230	4312.**0	67	5545.**0	309
1661.**0	261	3161.**0R	231	4360.**0	68	5546.**0	309
1662.**0	261	3162.**0R	231	4360.**0BT	69	5548.**0	309
1664.**0	262	3162.**2R	232	4360.**4	68	5550.**0	309
1665.**0	262	3163.**0R	232	4361.**0	68	5704.**2	304
1668.**0	257	3164.**0R	233	4361.**0BT	69	5704.**2R30	304
1669.**0	258	3165.**0	244	4361.**4	68	5704.**3	304
1669.**2SQ	258	3204.**0	110	4363.**0EDT	70	5704.**3R30	305
17EDI.99	8	3205.**1	111	4363.**0EGT	70	5704.**5	305
1800.66.*	265	3205.**2	111	4363.**0IDP	71	5704.**5R22	305
1801.66.*	264	3206.**0	110	4363.**0IGP	71	5625H21.99	169
1802.66.*	266	3249.**0	192	4366.**0	73	5630.**0	289
1803.66.*	266	3250.**0	193	4367.**0AD	72	5630.**1	289
1803.66.3MR	267	3251.**0	193	4367.**0BC	72	5630.**2	298
1804.66.3	267	3255.**0	246	4380.**0	74	5630.**3	298
1805.66.*	268	3256.**0	246	4380.**4	74	5630.**4	298
1806.66.*	264	3257.**0	247	43800.**	169	5630.**5	299
1806.66.*MR	265	3258.**0	247	4381.**0	74	5630.**6	299
1809.66.0	268	3259.**0	194	4389.**0	75	5630.**7	196
2720.**2L15	210	3260.**0RCV	222	4391.00.0	88-95	5630.**8	289
2720.**2L22	212	3261.**0R	223	4400.**0	76	5631.**0	307

5631.99.2	196	C529.15	135	KL002/08.**	162	SLIDEMATIC2.12	17-38
5632H21.99	169	C532.15	137	KL002/10.**	162	SLS60M2.99	24
5635H21.99	169	C541.15	137	KL003.**	163	SM02.12	18-39
5652.30.0	307	C581.15	133	KL005.**	163	SM04.99	18-39
5660.**.0	301	C582.15	133	KLA01.**	163	SM07.99	18-39
5660.**.5	301	C600PG22.15	136-189	KPR01/08.**	98	T120.**.0	260
5660.**.6	301	C600PG30.15	136-189	KSL100M1.**	26	T180.**.0	260
5723.**.0	196	C601PG22.15	136-189	KSL100M2.**	26	TAGSHINE.99	3
5724.15.D21	312	C601PG30.15	136-189	KSL60M1.**	22	TELESHINE	3
5724.15.D33	311	C603PG.15	137	KSL60M2.**	22	U151515.**	24-28-32-160
5725.15.0	311	CISL82M1.15	36	KSL81M1.**	30	U151515.13	161-252
5725.15.D21	312	DC422.5.99	171	KSL81M2.**	30	U201220.13	161-252
5725.15.D33	311	DC423.0.99	172	KSL82M1.**	30	U201520.13	161-252
5726.15.D21	312	DC423.2.99	172	KSL82M2.**	30	U201720.13	161-252
5726.15.D33	311	DC423.5.99	172	KSLD60M1.**	198	U202020.**	24-28-32-43-160
5727.15.D21	312	DC424.2.99	173	KSL560M2.**	23	U202020.13	161-252
5727.15.D33	311	DC424.5.99	173	L1515.13	161-252	U302030.*	160
5870.99.0	274	DC453.0.99	175	L2020.13	161-252	U302030.13	161-252
5870.99.1	274	DC453.2.99	175	L2525.13	161-252	U402040.13	161-252
600/1.**	43	DC453.5.99	175	MAGC3000.99	9	V206.15	115
842/2.15	7	DC454.0.99	176	MODSHINE	3	V207.12	115
94T.**	43	DC454.2.99	176	MS342900.35	147	V2140.15	94
9701.**.4	5	DC454.5.99	176	MS429060.35	147	V2140.2.15	94
9702.**.4	5	DC475.0.99	181	MS429060H.35	147	V310.**	86
9703.**.4	5	DC475.2.99	181	MS4432.35	147	V310CHOL.**	14
9704.**.4	6	DC475.5.99	181	MSL80M1.12	34	V310CHOR.**	14
9705.**.4	6	DC477.0.99	179	PF242.**	144	V330.**	86
9706.**.4	6	DC477.2.99	179	PF243.**	144	V340.**	87
AC246.33	132-151	DC477.5.99	179	PF500.**	140	V350.**	85
AC269.**	181	DC500.73	63-166	PF501.**	140	V360.**	90
AC299.33	132-141	EF01/V4.**	44	PF502.15	141	V360CHL.**	13
AC307.**	171-172-173	EF02.**	44	PF508.**	142	V360CHR.**	12
AC340.99	182	EF03.**	44	PF510.**	142	V360SQ.15	93
AC341.99	182	EF04.**	45	PF511.1.**	142	V367.**	91
AC342.99	182	EF06.**	45	PF514.**	143	V370.**	91
AC350.99	182	EF07.**	45	PF518.**	143	V370CHL.**	12
AC360.99	182	EF08.**	46	PF528.**	143	V370CHR.**	13
AC361.99	182	EF09.**	46	PF535.**	140	V370SQ.15	93
AC362.99	182	EM2819.**.3	249	PF581.**	141	V377.**	91
AC363.99	182	FLEXystack 250	54	PS01PMR/08L.**	102	V380.**	115
AC364.99	182	FRB01.99	154	PS01PMR/08R.**	102	V502.15	132
AC365.99	182	FRB02.99	154	PS02.99	102	V504.**	103
AC366.99	182	FRB03.99	154	PS09.99	103	V504.**	108
AC384.99.0	183	FRBDS02.99	151	PS1500.**	102	V505.**	109
AC392.99.0	183	FRE14.**	154	PS2500.**	102	V505.2.**	113
AC393.90.0	183	FRKB01.99	158	RS02.99	103	V506.**	115
AC500.25.73	63-166	FRP02B/**.12.E	10	S110.**.0	259	V507	46
AC534.**	179	FRP02B/10.**	151	S120.**.0	259	V507.**	109
AC612.99	182	FRP02B/12.**	151	S130.**.0	259	V525.**	84
AC616.15	175-176-177	FRP02BL/10.**	151	S140.**.0	259	V525.5.**	88
AC8.10.0	183	FRP02BL/12.**	151	S150.**.0	260	V526.**	85
AMGMODEL/**.15	58-190	FRP02O/10.**	152	S151.**.0	260	V527.**	87
AMT140192.15	186	FRP02O/12.**	152	S152.**.0	260	V533.1.**	89-95
AMT200300.15	186	FRP02OL/10.**	152	S154.**.0	260	V554.2.**	88
AMT200500.15	186	FRP02OL/12.**	152	S171.**.3	129	V590.**	120
AMT200700.15	187	FRP06B/10.**	153	S229.99.4	129	V750.**	88
AMT201200.15	187	FRP06B/12.**	153	S229.99.6	129	V770.**	94
AMT300300.15	188	FRP06O/10.**	153	SHINE.99	3	V780.**	94
AMT300500.15	188	FRP06O/12.**	153	SL10.**	24-28-32	WPROF02/03.13	250
AUTOSWING.73	19-167	FRP07B/**.12.E	10	SL100.99	28		
BGSHINE.99	3	FRP07B/10.**	152	SL15/**.**	24-28-32		
C222L.15	134	FRP07B/12.**	152	SL195.**	24-28-32		
C222R.15	134	FRP07BL/10.**	153	SL27.**	58-190		
C223L.15	135	FRP07BL/12.**	153	SL60.99	24		
C223R.15	135	K3172.90	114	SL600.99	24-28-32		
C500D.15	130	Kits serrure		SL81.99	32		
C500L.15	130	Kits lock LAGUNE	75	SL82.99	32		
C501.15	131	Kits serrure		SL93.**	58		
C502.15	131	Kits lock LUMIRA	89	SL94.**	58		
C511.15	131	KL001/08.**	162	SL95.**	58		
C528A.15	133	KL001/10.**	162	SL96.**	58		
C528B.15	133	KL001/12.**	162	SLIDEMATIC1.12	17-38		

A series of horizontal dotted lines for writing notes.

A series of horizontal dotted lines for writing notes.

A series of horizontal dotted lines for writing notes.

ASSA ABLOY is the global leader in door opening solutions, dedicated to satisfying end-users needs for security, safety and convenience*

*ASSA ABLOY est le leader mondial des solutions d'accès destinées à répondre aux exigences de sécurité, de protection et de confort de l'utilisateur final

ASSA ABLOY GLASS
Services administratifs
rue Alexandre Fichet
80460 Oust-Marest - France
www.assaabloy.fr/glass

Administration des ventes (France)
Tél : +33(0)1 39 46 11 88
Fax : +33(0)3 22 23 28 01

Sales administration (International)
Tél : +33(0)3 22 23 76 02
Tél : +33(0)3 22 23 76 12
Fax : +33(0)3 22 23 28 01

Relation Technique Clients
Tél : +33(0)1 39 46 11 88
support.glass@assaabloy.com

Customer technical support
Tél : +32(0)474 26 27 01
support.glass@assaabloy.com