

MILLING MANUAL

FritsJurgens®
SYSTEM M

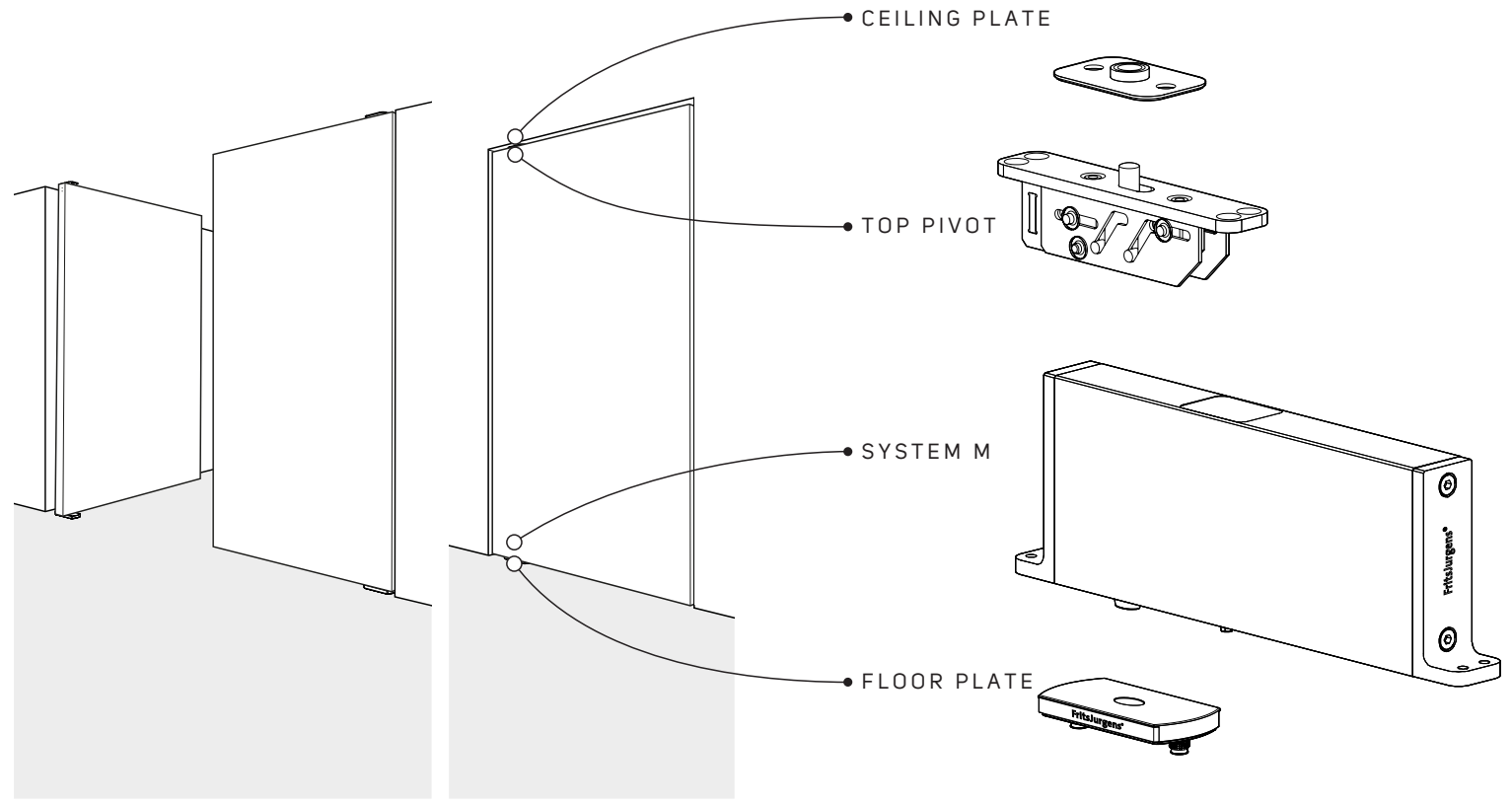

TOOLS INCLUDED

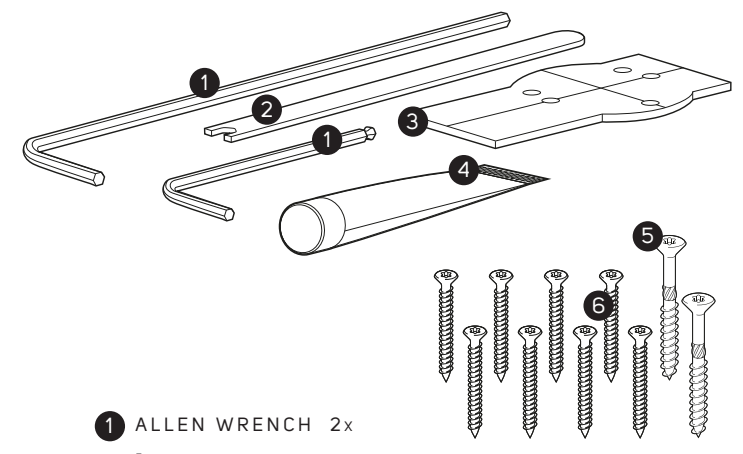

- 1 ALLEN WRENCH 2x
-
- 2 ADJUSTMENT SPANNER
-
- 3 FITTING TEMPLATE
-
- 4 FITTING ADHESIVE
-
- 5 RVS SCREW (6X60) 2x
-
- 6 RVS SCREW (4X50) 8x

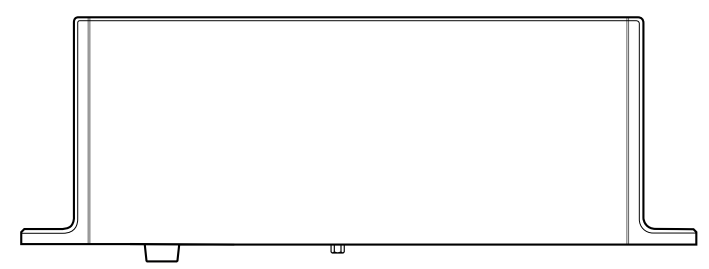

CEILING PLATE

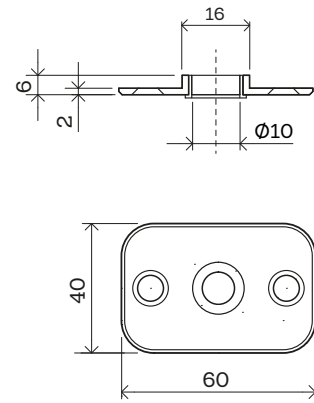

SYSTEM M

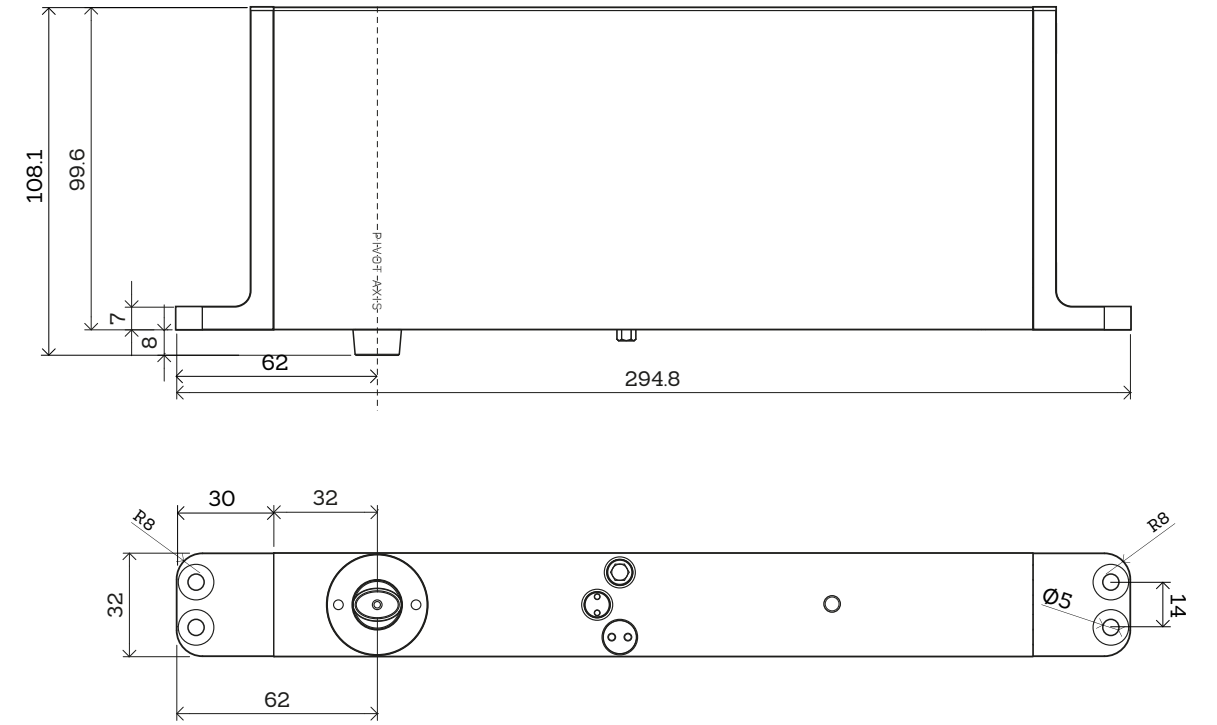

TOP PIVOT

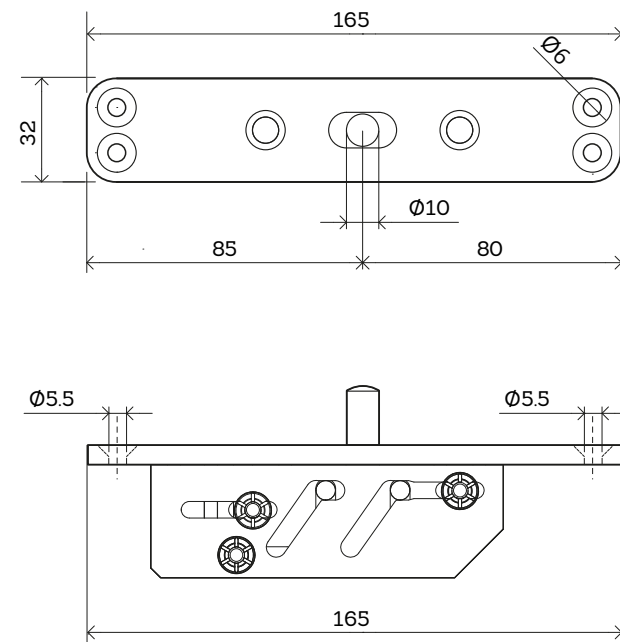

FLOOR PLATE

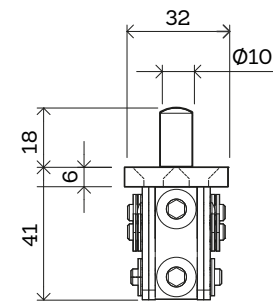
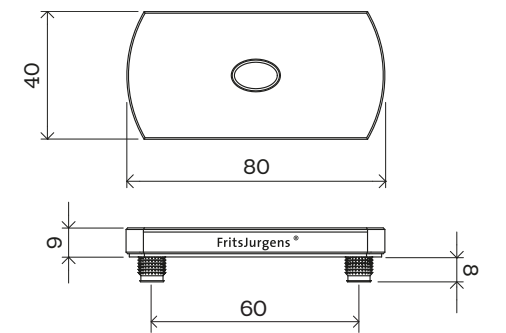

TOP PIVOT

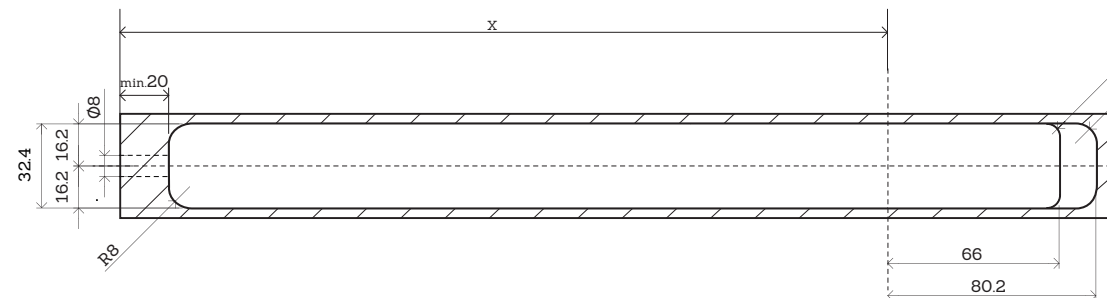
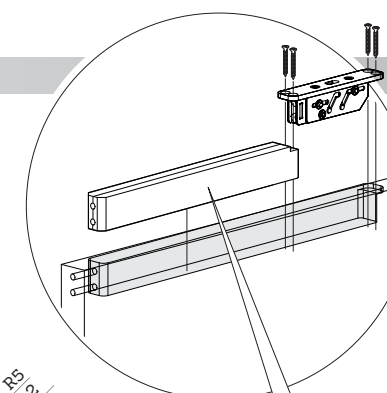
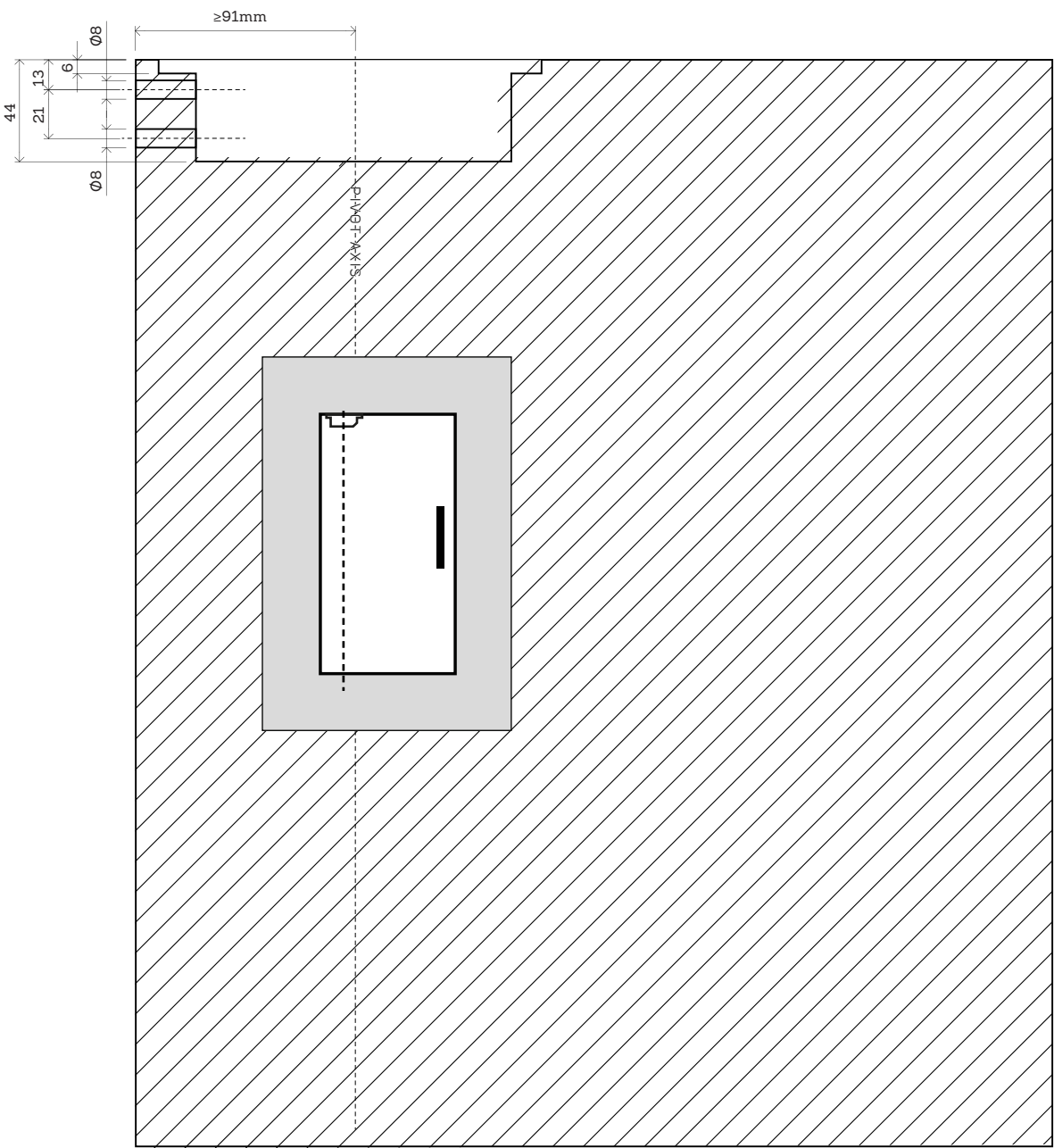
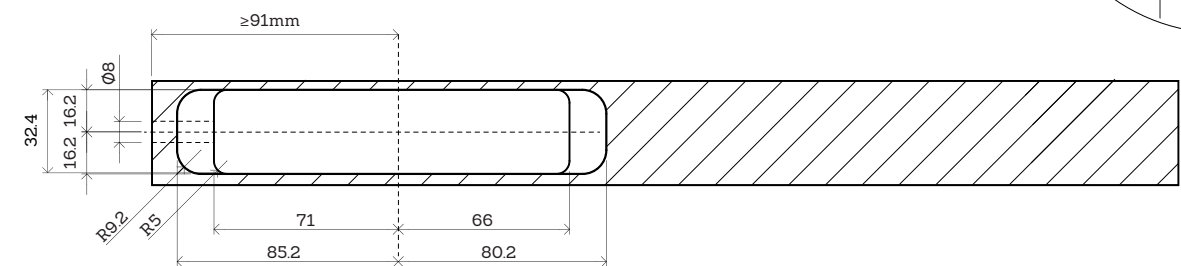
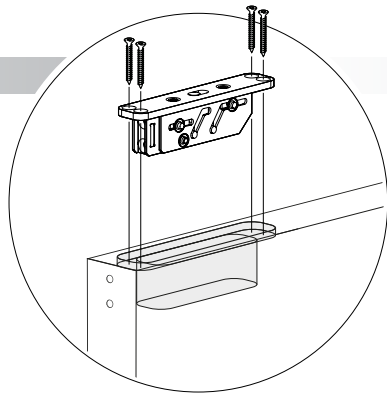

WHEN DISTANCE FROM DOOR
EDGE TO PIVOT POINT IS
GREATER THAN 280MM/11 IN.

RECOMMEND: FRITSJURGENS
HEXAGON GUIDE - 706000

